

TRANSVERSE BEAM PROFILE MEASUREMENTS FOR HIGH POWER PROTON BEAMS

P. Ausset, S. Bousson, D. Gardes, A.C. Mueller, B. Pottin, I.P.N., 91406, Orsay, France,
 R. Gobin, CEA Saclay, 91191, Gif sur Yvette, France,
 G. Belyaev, I. Roudskoy, ITEP, Moscow, Russia

Abstract

High power proton accelerators (H.P.P.A.) projects are being proposed in fundamental and applied physics research: radioactive beam production, neutron sources, neutrino factories and transmutation. Among the parameters needed to be measured, the transverse beam profiles are the most difficult to obtain. A very attractive phenomenon is the production of visible light by the proton beam-background or additional gas interaction. Transverse beam profiles of the "S.I.L.H.I." E.C.R. source (95 keV, 100 mA) have been measured. The Doppler effect has been brought into operation to determine the energy and the spatial extension of the different components of the beam (H^+ , H_2^+ , H_3^+).

Wire scanners are also usable under low duty factor pulsed beam operation. Experiments have been conducted on tungsten, tantalum, titanium and carbon wires intercepting a 5 MeV proton beam delivered by the TANDEM accelerator of the Institut de Physique Nucléaire d'Orsay. Transverse beam profiles have been deduced from: back-scattered protons, X and γ emission; and electric current collected in the wires.

1 INTRODUCTION

The I.P.H.I. (high intensity proton injector) project (C.E.A. / C.N.R.S. collaboration), which could be the front end of a High Energy Proton Accelerator (H.P.P.A.) is based on a E.C.R. proton source "S.I.L.H.I." (95 keV, current \approx 100 mA. A Radio Frequency Quadrupole (R.F.Q.) will follow to accelerate protons at 5 MeV. Finally the beam energy will be increased up to 10 MeV by a drift tube LINAC (D.T.L.). I.P.H.I. is able to work under pulsed mode operation for machine commissioning and experimental operation and under C.W. operation. The beam average power reaches 10 kW at the entrance of the R.F.Q. and 500 kW at the exit. Accurate measurement of the transverse beam profiles are strongly required for beam monitoring, halo formation prevention and minimisation of beam losses.

2 PROFILE MEASUREMENT METHODS

2.1 Slow Wire Scanner (S.W.S)

In this method, a wire is stepped in small increments through the beam. The profiles are obtained over many pulses by measuring the current flowing in the wire resulting from the secondary electrons emitted from this wire, subtracted from the protons collected by this wire.

The heating of the wire is the major problem because of the large energy deposited by the beam in any intrusive sensor. A crude estimation of the attained temperature is given by the resolution of the heat equation: The pulse duration must remain below 300 μ s and the repetition rate above 1 s in order to maintain the peak temperature of a carbon fiber (diameter: 30 μ m) below 1200 °K. in a 5 MeV, 100 mA, 320 mA/cm² proton beam. S.W.S. are only usable under low duty factor operation.

In the case of slightly higher beam average powers, the amplitudes of the mechanical deformations increase and thermo-ionic emission of electrons occurs which distorts the measurements of the true profiles. At higher beam average power and under C.W. mode operation any kind of fiber is destroyed.

2.2 Fast Wire Scanner (F.W.S.)

At high average power pulsed beam and under C.W. operation, the wire must go very quickly through the beam. It was found that the speed of the wire must then exceed 60 m/s to withstand the power of a C.W.; 5 MeV; 100mA; 320 mA/cm² proton beam. Because of this high speed, a F.W.S. is very difficult to design.

2.3 Optical Based Profiles Measurements

Moderately relativistic protons lose energy by ionisation caused by inelastic collisions in the residual gas (mainly hydrogen) present in the vacuum. The gas fluoresces and light is emitted in the visible range from excited atoms. Therefore, a profile may be measured by sensing this light with a C.C.D. camera. For high average power beam, a very attractive profile monitor, specially because of its non destructive nature with respect to the beam, can be thought out.

3 EXPERIMENTS WITH WIRE SCANNER

Even under low duty-factor pulsed-beam, the heating of the wire of a S.W.S. may bring out errors in the profile measurements in particular because of the thermo-ionic emission of electrons. In order to design our S.W.S. for I.P.H.I., and to crosscheck the measurements of the current traditionally used in S.W.S., we looked for physical processes, the characteristics of which does not depend on the temperature.

Valid candidates are:

- The production of back scattered protons due to elastic collisions between the protons of the beam and the atoms of the wire.

- The production of γ (and X) ray due to the excitation or nuclear reaction of the nucleus caused by inelastic collisions between the accelerated protons with the atoms of the wire.

3.1 Experimental Setup

The tests were carried out on the TANDEM accelerator of the “Institut de Physique Nucléaire d’Orsay” in a 5 MeV and 1 μ A proton beam (Fig 2). A frame on which different samples of wire were fixed can be translated through the vacuum vessel. The current flowing in the wire was measured by a current to voltage converter, the current of the beam with a Faraday cup.

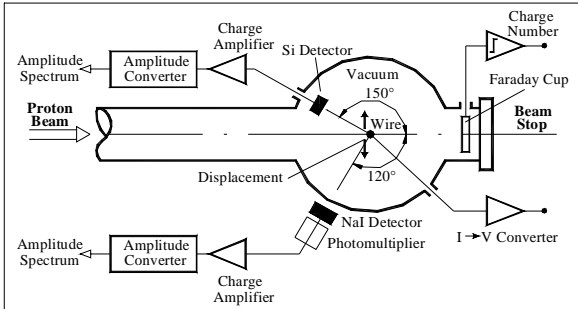

Figure 2: Top view of the experimental set up

The amplitude of the pulse delivered by the charge amplifier associated with the Si junction is proportional to the energy deposited by the back scattered protons. The transverse beam profiles are deduced by integrating the whole spectrum for each position of the wire. The same is done for the detection of the γ ray after detection with a NaI scintillator associated with a photo-multiplier. At last a specific software was used to fit the measured profiles.

3.2 Experimental Results

Wires of different nature and diameters (ϕ) were tested: W ($\phi = 100 \mu\text{m}$ and $500 \mu\text{m}$), Ta ($\phi = 100 \mu\text{m}$), Ti ($\phi = 125 \mu\text{m}$, $500 \mu\text{m}$), C ($\phi = 1 \text{mm}$).

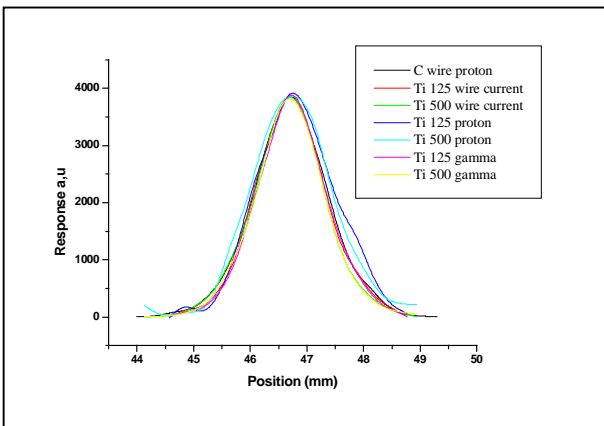

Figure 3: profiles measurements for a C wire ($\phi = 1 \text{mm}$) and Ti wires. ($\phi = 125 \mu\text{m}$, $500 \mu\text{m}$).

- It was first checked that the profiles measured with the different wires were similar and did not depend on the diameter of the wire.
- For example, the profiles deduced from the back-scattered protons, the γ ray production and the current measured with the Ti wire are very similar (Fig 3).

The first experiments show a very good agreement in the profiles measured with the different wires independently of the physical processes involved in the measurements. The total error in the measurement of the width is in the order of $250 \mu\text{m}$.

4 OPTICAL BASED MEASUREMENTS

Our experiments were carried out in a “diagnostics box” located after the two solenoids which focus the beam in the Low Energy Beam Transport line (L.E.B.T.) following the E.C.R. source S.I.L.H.I. now on operation.

4.1 Fluorescence Beam Profile Measurements (F.B.P.M.)

This technique collects through an optical lens, and integrates with a C.C.D. camera the photons resulting from the beam-background residual or added gas interaction. The residual gas is mainly hydrogen (pressure: 2.10^{-3}Pa). Other gas such as N, Ne, Ar, Kr, Xe, were also injected into the diagnostics box at different pressure. Two 16 bit C.C.D. intensified camera were installed perpendicular to the axis of propagation of the proton beam in order to perform horizontal and vertical profile measurements. Specific software allowing for background signal subtraction to increase Signal/Noise, vertical and horizontal projections (profiles calculation) and peak fitting convolution were used to obtain the final profiles. It has been found that:

- The proton beam is cylindrical in the L.E.B.T.
- The intensity of the emitted light depends on the nature of the gas and increases proportionally to the pressure of the gas.
- Same profiles are obtained (after normalisation with respect to the amplitudes of the signals) for all gas at identical pressure.

4.2 Spectroscopic Measurements

A photo-multiplier was coupled to a scanning monochromator to analyse the emitted light spectrum. The well-known lines of the Balmer series: H_{α} , H_{β} , H_{γ} were re-found. We also measured specific lines of the other gases in the 200 nm-820 nm range.

4.3 F.B.P.M. (Pulsed Mode Operation)

In low duty factor operation, the width of the profiles measured by F.P.G.M. is always greater than the one deduced from a classical grid profiler [3] This is attributed to the existence of a halo surrounding the “core” of the beam, the origin of which involves many physical processes leading to the production of light by the gas. Several processes may be pointed out:

- The back-scattered protons can excite atoms of the gas this will produce light.
- Inelastic collisions may produce also electrons able to excite in their turn atoms of gas.
- S.I.L.H.I. produces, in addition to the protons, H_2^+ and H_3^+ . Dissociation of these molecules may occur, excited atoms are produced and can become source of light.

4.4 Shifted Doppler Fluorescence Beam Profile Measurements

The light produced does not result only from the incoming protons, but also from several secondary processes which create excited atoms. We will focus now on protons coming from the source at the nominal energy and accelerated back-stream by the R.F.Q. At this energy, their electronic capture cross section is high. They may then give birth to very specific excited atoms of Hydrogen at 95 keV. The Doppler shift effect in the frequency (or wavelength) domain will discriminate the light produced by de-excitation of these atoms among the overall light.

The experimental setup is based on the use of the same C.C.D. intensified camera installed in the focal plane of a monochromator equipped with a 900 gr/nm grating. The resolution was better than 0.1 nm at 500 nm.

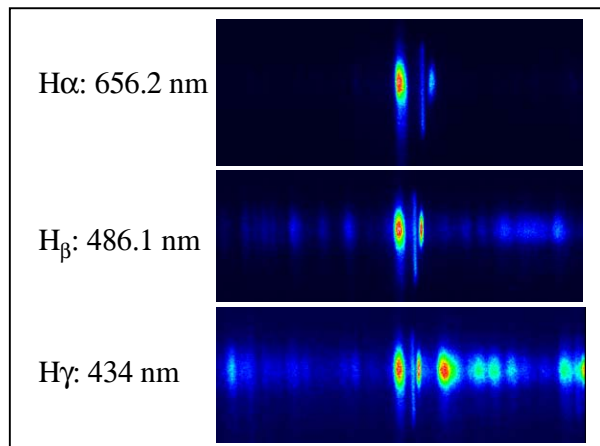

Figure 4: Doppler effect on Hydrogen Balmer lines

The beam profiles, according to the slit orientation at the entrance of the monochromator, are deduced from the analysis of the image transported on the C.C.D. camera.

In addition, due to the possible discrimination of the different components of the beam: H^+ , H_2^+ , and H_3^+ because of their different Doppler shift wavelength, this method allows for the identification, the measurement of the relative intensity and the transverse profiles of the different species of the beam. The width of each line is proportional to their energy spread.

As an example, we measured the F.W.H.M of the profiles of the H_α component and its corresponding Doppler shift line (Fig 5) during the variation of the beam focusing by varying the solenoid current. It must be noticed that the size of the “halo” around the “core” of the beam remains constant.

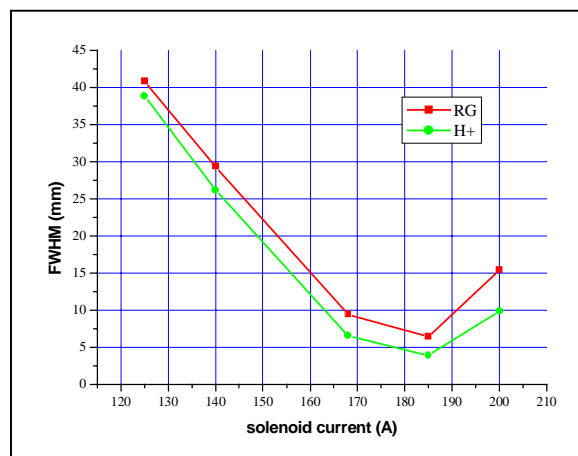

Figure 5: F.W.H.M. of the profiles measured for H_α (R.G.) and its corresponding Doppler line (H^+) versus different configuration of the beam focusing.

5 CONCLUSION

We developed specific tools for the measurement of the transverse profiles of high power proton beam.

- Under low duty factor pulsed beam operation traditional wire scanner work. Measurements of back scattered protons or γ ray production are powerful tools to cross check the measurement of the current in the wire in the temperature range of the wire below thermo-ionic emission. Measurements by means of a wire scanner may be also cross checked with Doppler fluorescence beam profile measurements.
- The fluorescence beam profile measurement is valid for centroid beam position measurement and qualitative measurement of the width of the beam profiles.
- At high average power proton beam, the Doppler fluorescence beam profile measurement is a very promising method to identify the species in the beam, to measure their energy and hopefully their energy spread. Beam profiles measurements are underway.

ACKNOWLEDGEMENTS

We want to acknowledge A. Tkatchenko and J. L. Coacolo for their interest in the thermal analysis of the wire. We thank the “S.I.L.H.I.” team for their constant support and also B. Waast and the I.P.N.O. Tandem team.

REFERENCES

- [1] P. Ausset and al, “Optical transverse beam profile measurements for high power proton beam, E.P.A.C’02, Paris, June 2002.
- [2] P. Ausset and al, “Beam diagnostics for high intensity accelerators, Workshop on utilisation and reliability of high power proton accelerators, Aix en provence, France 22-24 November 1999. (N.E.A.)
- [3] J.D. Gilpatrick, “Techniques for intense-proton-beam profile Measurements, B.I.W 1998.