

# PROGRESS IN THE FABRICATION OF THE RFQ ACCELERATOR FOR THE CERN LINAC4

C. Rossi, P. Bourquin, J.B. Lallement, A.M. Lombardi, S. Mathot, D. Pignat, M. Timmins, G. Vandoni, M. Vretenar, (CERN, Geneva), M. Desmons, A. France, Y. Le Noa, G. Novo, O. Piquet, (CEA, Gif-sur-Yvette)

## Abstract

The construction of Linac4, the new 160 MeV CERN H<sup>-</sup> injector, has started with the goal of improving the LHC injection chain from 2015 with a new higher energy linac. The low energy front end of Linac4 is based on a 352 MHz, 3-m long Radiofrequency Quadrupole (RFQ) accelerator [1]. The RFQ accelerates the 70 mA, 45 keV H<sup>-</sup> beam from the RF source to the energy of 3 MeV. The fabrication of the RFQ has started at CERN in 2009 and is presently in progress, aiming at the completion of the full structure by early 2011.

The RFQ consists of three modules, one meter each; the fabrication alternates machining phases and stress relief cycles, for copper stabilization. Two brazing steps are required: one to assemble the four parts composing a module, and a second one to install the stainless steel flanges.

In order to monitor that the tight mechanical and alignment budget is not exceeded, metrology measurements at the CERN workshop and RF bead-pull measurements are performed during the fabrication process.

In this paper we report results obtained during the machining and the assembly of the first module of the Linac4 RFQ and data produced by RF measurements performed during its fabrication.

## INTRODUCTION

The mechanical design and the fabrication of the Linac4 RFQ are completely performed at CERN [2], in contact with the CEA and INFN teams that have recently realized the IPHI and TRASCO RFQs which were both partially (IPHI) or entirely (TRASCO) brazed at CERN. Additionally, CEA is directly contributing to the CERN Linac4 RFQ with a set of thermo-mechanical calculations, with the detailed RF design and by performing all RF low-level measurements.

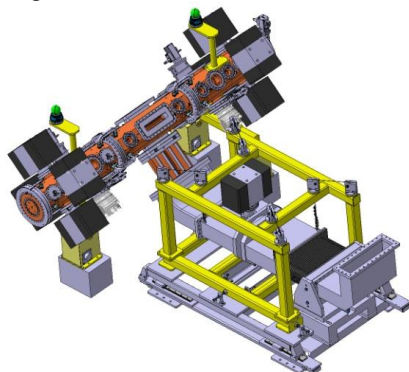

Figure 1: The Linac4 RFQ on its support.

The machining and fabrication of the RFQ are bound by tight tolerances that are justified by the requirements on the accelerating field and on the wide range of beam currents that must be accelerated. Fabrication tolerances are summarized in Table 1.

Table 1: Mechanical tolerances in the Linac4 RFQ fabrication.

Linac4 RFQ Tolerances	Value	Units
Machining error	$\pm 20$	$\mu\text{m}$
Vane modulation error	$\pm 20$	$\mu\text{m}$
Vane tilt over 1 m	$\pm 100$	$\mu\text{m}$
Vane positioning error (displacement h+V)	$\pm 30$	$\mu\text{m}$
Vane thickness error	$\pm 10$	$\mu\text{m}$
Contiguous section gap	$100 \pm 15$	$\mu\text{m}$
Section tilt over 1 m	$\pm 30$	$\mu\text{m}$

## MECHANICAL FABRICATION

The most relevant aspects of the mechanical fabrication concern the realization of the RFQ cavity and of the vacuum ports, where new solutions have been found to simplify the realization.

### RFQ Cavity

The RFQ cavity has an octagonal 2D section and is made of two major vanes and two minor vanes that are brazed together during the first brazing step. Three modules, named T1, T2 and T3, are joined together to form the three meter structure.

In order to minimize technical problems of vane displacements during the first critical brazing step, a fabrication procedure has been defined to reduce to a minimum residual mechanical stresses in the copper

After each fabrication step, complete metrology measurements are performed and, after first manual assembly, first brazing and second brazing, RF bead-pull measurements are performed in addition.

### Vacuum ports

A total of 16 vacuum ports are built in the first and last module of the Linac4 RFQ. Their design minimizes the electromagnetic field penetration inside the port aperture.

Thermo-mechanical simulations have shown that they do not require a cooling system.

The compensation for the field distortion introduced by the vacuum port is an important ingredient of the final accelerating field quality. In the Linac4 RFQ the vacuum ports are assembled at the second brazing step, so to allow

the precise measurement of the required penetration into the RFQ cavity during RF bead-pull measurements.



Figure 2: Trying different penetration depths of vacuum ports in one RFQ quadrant.

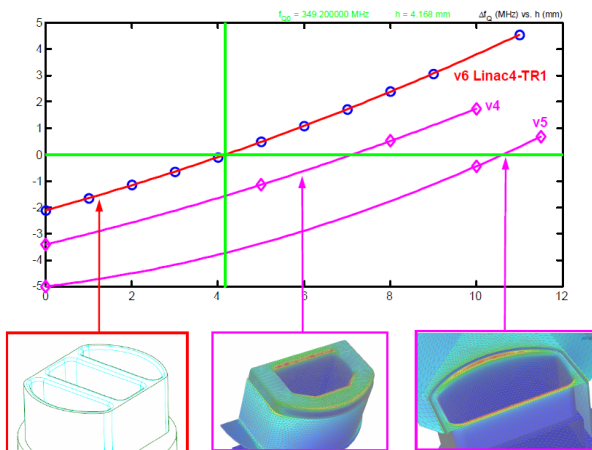

Figure 3: Plot showing the penetration depth for different vacuum port geometries.

In Figure 3 the penetration value for the chosen geometry (red curve) is compared to other geometries that were initially considered for vacuum ports. A penetration value of 4.17 mm has been adopted for T1; which takes also into account the effect of vacuum port bore gaps.

A loaded, lossless 4-wire transmission line model is used to simulate the RFQ electromagnetic circuit [3], where a deviation from the ideal behaviour is associated to a capacitance error.

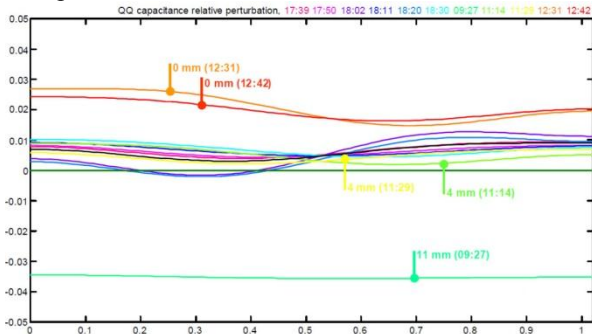

Figure 4: Estimate of the  $C_{QQ}$  capacitance error, associated to the fundamental accelerating mode, with vacuum ports at different penetration values (processed data from bead-pull measurements).

The impact of different port penetrations on the average capacitance error is well visible in Figure 4, where it is compared with errors in the presence of dummy blocks at flush positions. The green trace shows how well the port perturbation is compensated by a 4 mm penetration into the cavity quadrants.

## MEASUREMENTS

Metrology measurements, performed at CERN with an OLIVETTI Inspector 900v instrument, follow each fabrication step. RF bead-pull measurements are used to check the accuracy of the assembly and to decide the positioning of vacuum ports.

### Metrology measurements

The T1 vanes were measured at all phases of the fabrication process. Figure 5 shows the T1 module after brazing during metrology measurements.

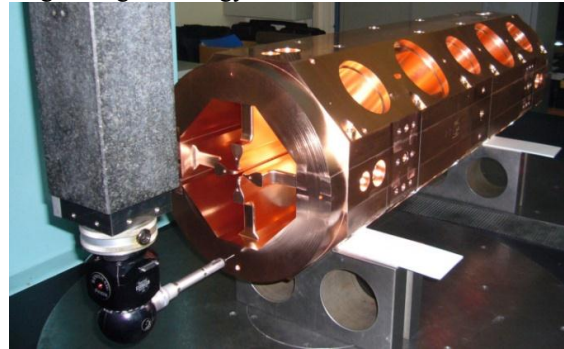

Figure 5: T1 at the CERN metrology workshop after the first brazing.

Reference surfaces are machined at each fabrication step and the CAD tool provides the metrology system with the ideal vane and cavity profile as a reference.

An example is given in Figure 6, where the vane profile has been measured at a given longitudinal coordinate and compared to the ideal profile (green line) with a tolerance mask (red).

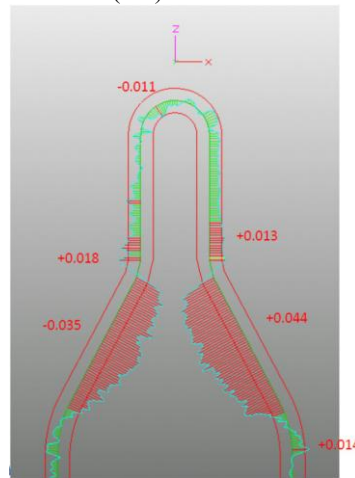

Figure 6: T1 vane profile. Measured profile compared to tolerance (deviation values in mm).

A considerable amount of time has been spent for validating the machining procedure and tools.

Metrology measurements have equally allowed assessing the outcome of the first brazing step. In Figure 7 distances between the 4 reference pin holes on each adjacent vane tips are compared before and after the first brazing (values in mm); the ideal value (green) is the reference for the quadrupole symmetry.

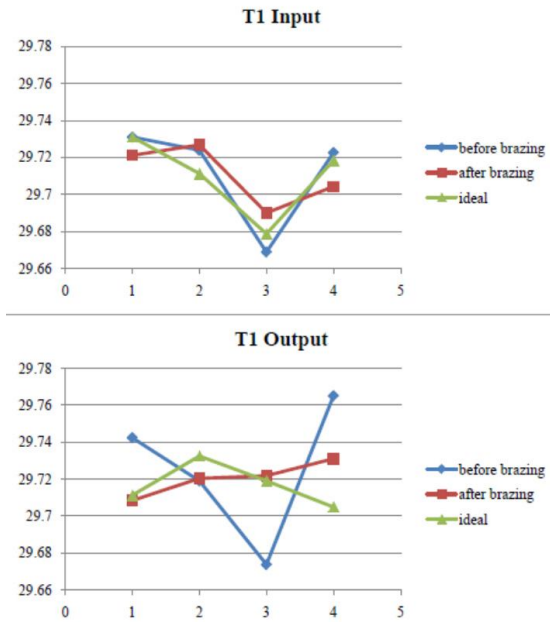

Figure 7: T1 metrology results before and after brazing.

### RF bead-pull measurements

A dedicated bead-pull test bench, shown in Figure 8, has been fabricated and delivered to CERN by CEA Saclay in the frame of the collaboration work performed on the Linac4 RFQ.

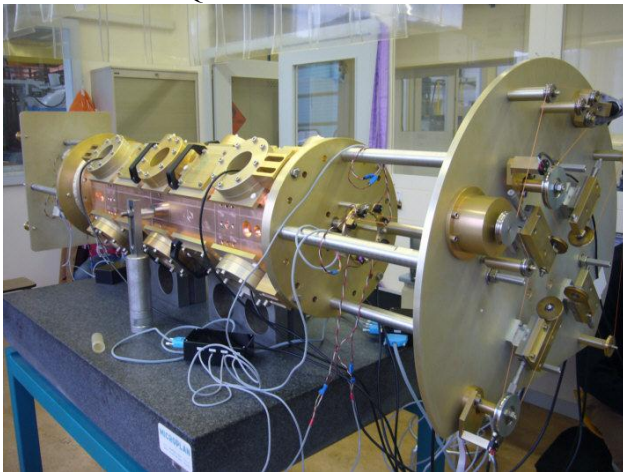

Figure 8: The RFQ RF test bench.

By sampling electromagnetic fields in the four RFQ quadrants, bead-pull measurements may disclose errors in the fabrication process that, in the end, may produce a modification of the accelerating field profile with respect to design.

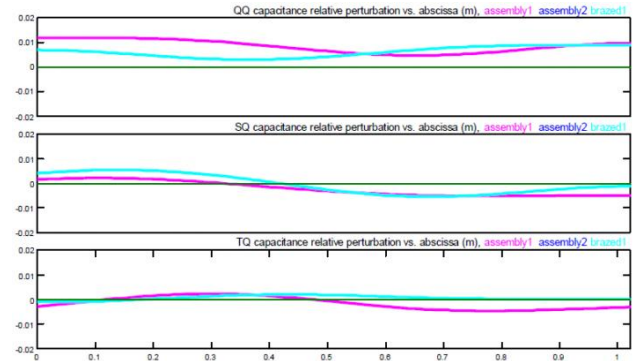

Figure 9: Quadrupole (QQ) and dipole mode capacitance relative errors, measured before (purple) and after (blue) brazing.

Figure 9 plots the capacitance relative errors for the quadrupole and dipole modes in T1, as obtained from bead-pull measurements. The tolerance budget is  $\pm 2.3\%$  for the quadrupole mode and  $\pm 3.5\%$  for dipole modes. A correction of  $-0.005$  must be applied to data concerning the quadrupole component (first of the three graphics above) to take the contribution of tuner and vacuum port bore gaps into account.  $C_{QQ}$  results then flat within an error range of  $-0.2\%$  to  $+0.4\%$ , which confirms the success of the first brazing.

Nonetheless the correspondence between the RF bead-pull results and the metrology measurements is not obvious yet.

## CONCLUSION

The initial fabrication phase of the first module of the Linac4 RFQ has been crucial for establishing the general work procedures and validating the tools. The first brazing has shown that the process is well handled.

The fabrication of the Linac4 RFQ was initially planned to be completed in 2010, to allow performing extensive beam tests at the Linac4 Test Stand, before starting the commissioning of the Linac4 in the tunnel.

The decision to delay the connection of Linac4 to the LHC injection chain to 2015 has allowed relaxing the RFQ fabrication schedule, thus leaving more time to metrology checks and to the tuning of the fabrication procedure. The RFQ is now expected to be completed in the first half of 2011 and start the RF commissioning and beam tests at the Linac4 Test Stand soon after.

## REFERENCES

- [1] C. Rossi et al., "The Radiofrequency Quadrupole Accelerator for the Linac4", Linac08, Victoria BC, Canada.
- [2] S.J. Mathot et al., "Mechanical Design, Brazing and Assembly Procedures of the Linac4 RFQ" IPAC10, Kyoto, Japan.
- [3] O. Piquet et al., "The RF Design of the Linac4 RFQ" IPAC10, Kyoto, Japan