

COMPLETION OF THE SOLEIL CRYOMODULE

P. Bosland*, D. Boussard **, P. Brédy*, S. Calatroni**, S. Chel*, E. Chiaveri**, M. Juillard*, R. Losito**, M. Maurier*, A. Mosnier*, F. Orsini*

* DAPNIA, CEA/Saclay, F-91191 Gif-sur-Yvette, France

** SL/RF, CERN, 1211 Geneva 23, Suisse

Abstract

The construction of the cryomodule initially planned for the SOLEIL project is underway by a collaboration between CEA Saclay and CERN. The two single cell cavities, equipped with superconducting loop couplers, have been designed to allow an efficient damping of HOMs. The 352 MHz Nb/Cu cavities were fabricated and tested at CERN, and reached $Q_0=3 \cdot 10^9$ at $E_{acc}=6$ MV/m and $T=4.5$ K, above specifications. The tuning system under vacuum is an improved version of the one developed for the TTF 9-cell cavities. The assembling of the cryomodule is presently in progress at CERN where RF power tests are planned to be performed before the end of year 1999.

1 INTRODUCTION

The cryomodule developed for the SOLEIL synchrotron light source starts its last round: the CEA DAPNIA/SEA group made the design; the CERN SL/RF group provided the two 352.2 MHz superconducting Nb/Cu cavities and the two 200 kW LEP main couplers; the cryomodule assembly is now being completed at CERN by both Saclay and CERN teams.

This accelerating unit is capable to provide a 500 mA, 2.5 GeV electron beam with a 400 kW CW RF power.

The design of the superconducting RF structure is based on the concept of the "HOM free cavity". The goal of such a structure is to efficiently damp all HOM's in order to avoid any coupled bunch instabilities [1]. To this end, superconducting single cell cavities can be loaded with ferrite rings placed inside end tubes. Such a design has already demonstrated required dampings (KEK [3], Cornell [4]). An alternative design, chosen for SOLEIL, consists in two single-cell connected by a large tube (400 mm diameter) on which are installed 4 superconducting HOM loop couplers.

The general layout of the SRF unit and the optimisation of the HOMs damping were described in previous papers [1], [2].

The complete cryomodule is able to provide a maximum RF voltage of 7 MV and is 3.2 m long. Thus, the whole unit including conical transitions, valves, bellows and pumping system can fit in a short straight section of 7 m long, in the SOLEIL storage ring, as required.

2 GENERAL LAYOUT

The cryomodule, 1.23 m in diameter, is represented in Fig. 1. Similarly to the LEP cryostat design, dismantlable hatches offer an easy access to couplers and tuners, without having to disassemble the system.

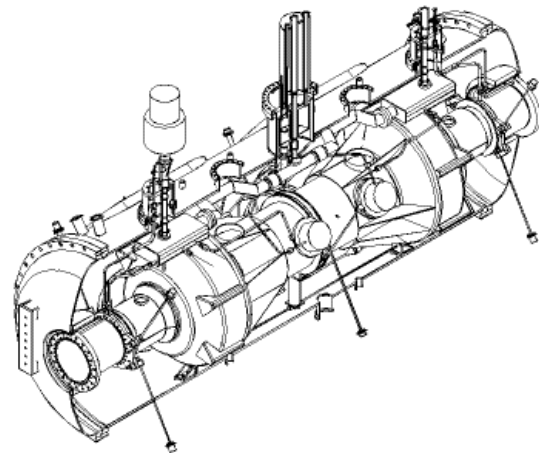

Figure 1: View of the cryomodule with the two helium tanks containing the cavities. (Tuning systems and power couplers are not represented).

In order to reduce any extra RF losses, the use of bellows "seen" by the beam was rejected. Thus, during cool down, the contraction of the cavities makes the power couplers move by about 2 mm along the cavities axis. The supports of the connecting waveguides are longitudinally free to accommodate this displacement.

Thermal flow between cavities at 4.5 K and the end of the cryostat at 300 K is limited by a double walled stainless steel tube. Cold helium gas flows in chicane between the two walls. Inside the tube, a $10 \mu\text{m}$ copper layer has been deposited by magnetron sputtering to reduce HOM RF losses.

Cavities are hold in the vacuum tank with titanium rods forming an X pattern. Such an arrangement preserves the alignment of the cavities during cool down.

3 CRYOGENICS

Thermal radiation shielding is ensured by multilayer insulation whereas no liquid nitrogen shielding is used. Each cavity has a separate helium tank in order to limit the liquid helium volume. This also permits to use the tank as a mechanical reference for the tuning system (see section 4.3).

The liquid helium is at 4.5 K, i.e. at a pressure of about 1.25 bar. A phase separator placed inside the cryostat, at helium input, limits the harmful effects of a diphasic LHe/gHe mixture. The helium gas collected at 4.5 K is partly used to cool the two beam end tubes and the two cold coaxial lines of the power couplers.

Table 1: Estimated heat losses.

<i>Static losses</i>		
Radiation	MLI40 layers+end tubes	14 W
Conduction	Instrumentation	5 W
	Supporting system	5.4 W
	Circuits (chimney...)	2 W
	Main couplers (2)	2 W
	End tubes (2)	2 W
Convection	Vacuum < 10 ⁻⁴ mb	< 0.2 W
<i>Dynamic losses</i>		
4.5 to 300 K	Main couplers (2)	0.4 g/s
4.5 to 300 K	End tubes (2)	0.28 g/s
At 4.5 K	HOM dipolar (2)	8 W
At 4.5 K	Cavities (3.5 MV/m)	50 W
TOTAL		100 W 0.68 g/s

4 FABRICATION AND ASSEMBLING

4.1 The two Nb/Cu cavities at 352 MHz

Cavity (Fig.2) fabrication and surface preparation were carried out at CERN, following the LEP and LHC procedures [5]. A 4 mm thick copper foil has been used for the manufacturing of the cavities. Almost 200 μm in total of copper had to be later removed from the surface to obtain a substrate suitable for niobium coating. The niobium films, 1.5 μm thick, were then successfully deposited in the new geometry by making small adjustments to the coating parameters, in particular for the cut-off tubes. As shown on Fig.3 the cavities performances exceeded specifications in vertical tests ($Q_0 = 1 \cdot 10^9$ at $E_{acc} = 6$ MV/m).

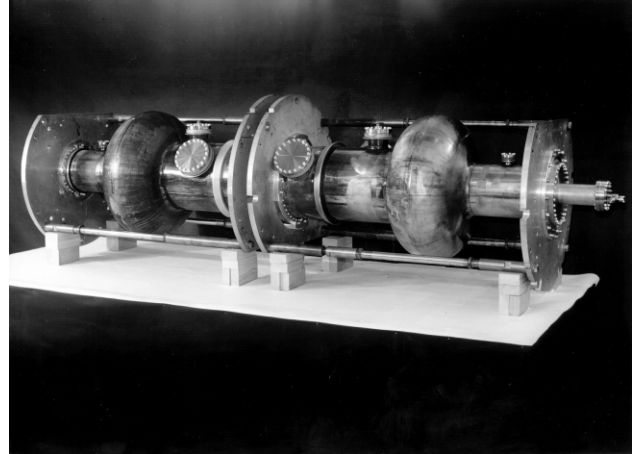

Figure 2: the two copper cavities after Nb deposition

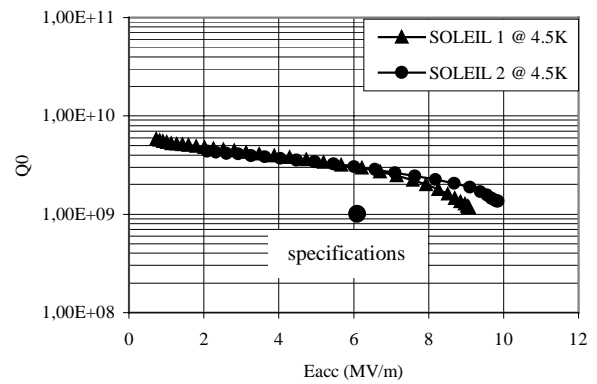

Figure 3: Q_0 versus the accelerating field curves of the two SOLEIL cavities at 4.5 K and 2.5 K.

4.2 The HOM couplers

Monopole and dipole types HOM couplers shown on Fig.4 and Fig.5 are made out of niobium. Inside the 30 mm diameter Nb loop tubes, a stainless steel tube drives the liquid helium to the end of the loop.



Figure 4: HOM coupler for monopole modes

Only the “dipole type” requires a notch filter very well centred on the fundamental frequency. As can be seen on Fig 5, four screws allow the tuning of these couplers once they are mounted on cavities, by pivoting the loop around.



Figure 5: HOM coupler for dipole modes.

4.3 The cavity tuning systems

Each cavity has its own cold tuning system (CTS) which works inside the cryostat at 4.5 K and under vacuum. This CTS, shown on Fig.6, is composed of a stepping motor able to work in such conditions, a gear box (1/50), a screw-nut system, and a double lever mechanism (1/30). Surfaces of the elements submitted to friction are plated with lubricating coatings.

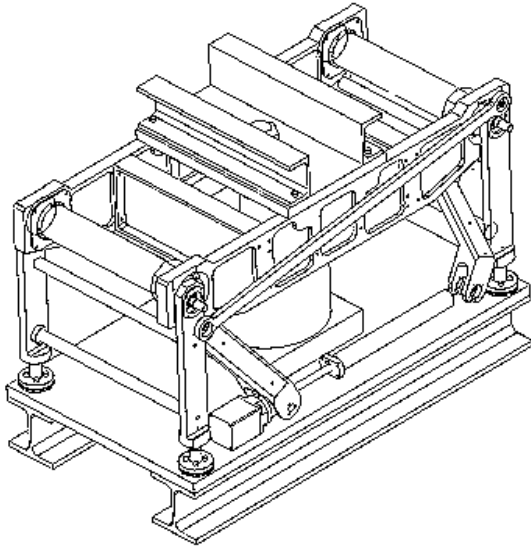

Figure 6: The tuning system of the cavities on its room temperature test stand. In the cryomodule, the four legs are fixed on the helium tank.

The helium tank is used as a mechanical reference. It was designed to ensure the required stiffness of the mechanical assembly. The CTS pulls the flange to extend the cavity thanks to a one wave bellow appropriately placed in the helium tank.

Tests were performed at room temperature to measure the stiffness of the CTS and the cavity frequency response (cavities were under vacuum, the helium tank and the cryostat were at atmosphere). Linearity and reversibility are very well satisfied in the range 0.5 mm either side from the central point.

The stiffness of the helium tank is 220 kN/mm, as calculated, and the CTS one is 55 kN/mm. The most flexible elements are the two girders which have been machined to make them lighter (each CTS weighs about 80 kg).

The measured tuning sensitivity is about 170 kHz/mm, close to the calculated value of 187 kHz/mm.

The total range of the system allows a cavity deformation of ± 3 mm, corresponding to about ± 500 kHz (if linearity is verified for deformations larger than 0.5 mm).

The theoretical resolution, better than 1 Hz, will be compared to the experimental one during the RF tests at 4.5 K.



Figure 7: The two cavities in their helium tank and tuning systems before insertion into the vacuum vessel.

5 FUTURE PLAN

After the final assembling, the RF tests at nominal power will be performed at CERN at the end of November 1999. Static and dynamic cryogenic losses will be measured, as well as the accelerating fields of the two cavities. Q of the dipole type HOM couplers will be determined again at 4.5 K. However, a complete commissioning must of course be made with beam.



Figure 8: Preparation of the assembly before the mounting of the power couplers in the clean room.

6 ACKNOWLEDGEMENT

We would like to thank all the people from CERN and CEA who contributed to this work. But we are specially indebted to A. Insomby from CERN, and to B. Coadou and G. Szégédi from Saclay, for their availability and competence in the mounting of such assemblies.

7 REFERENCES

- [1] "HOM Damping in SOLEIL Superconducting Cavity", A. Mosnier et al., Proc. of the European Part. Conf., Stockholm, Sweden, 1998.
- [2] "General Layout of the SOLEIL SRF Unit", A. Mosnier et al., Proc. of the 8th Workshop on RF Superconductivity, Abano Term (Padova), Italy, 6-10 October 1997.
- [3] "The superconducting cavity system for KEKB", T. Tajima et al., Part. Acc. Conf. 99, NY City, March 1999, pp 440-444.
- [4] "The High Luminosity Performance of CESR with the New Generation Superconducting Cavity", S. Belomestnykh, Part. Acc. Conf. 99, NY City, March 1999, pp 272-276.
- [5] E. Chiaveri, proceedings of the VII Workshop on RF Superconductivity, ed. B. Bonin (Gif sur Yvette, 1995), p. 181.