

PHIN

Initial commissioning experience with the superconducting RF photoinjector at ELBE

J. Teichert¹, A. Arnold¹, H. Buettig¹, D. Janssen¹, M. Justus¹, U. Lehnert¹, P. Michel¹,
P. Murcek¹, A. Schamlott¹, Ch. Schneider¹, R. Schurig¹, F. Staufenbiel¹, R. Xiang¹, T.
Kamps², J. Rudolph², M. Schenk², G. Klemz³, I. Will³,

- 1) FZD, Dresden, Germany
- 2) BESSY, Berlin, Germany
- 3) MBI, Berlin, Germany

Abstract

A radio frequency photo injector with a superconducting acceleration cavity (SRF gun) for installation at the Radiation Source ELBE was developed within a collaboration of BESSY, DESY, FZD, and MBI. Beside the operation at ELBE, the SRF gun together with its diagnostic beam line is an excellent test bench for extended studies and improvements of this new and promising injector type. The gun cryostat, the electron diagnostic beamline, and the driver laser with optical beamline were installed in summer and fall 2007. In November the first beam was produced. It will be reported on the experience gained at the first phase of commissioning. Results of rf and beam parameter measurements with Cs₂Te photo cathodes are presented.

Contribution to the “Free Electron Laser Conference FEL08”, Gyeongju (South Korea),
24-29 August 2008

Work supported by European Community-Research Infrastructure Activity under the FP6
“Structuring the European Research Area” programme (CARE, contract number RII3-CT-
2003-506395)

INITIAL COMMISSIONING EXPERIENCE WITH THE SUPERCONDUCTING RF PHOTOINJECTOR AT ELBE*

J. Teichert[#], A. Arnold, H. Buettig, D. Janssen, M. Justus, U. Lehnert, P. Michel, P. Murcek, A. Schamlott, Ch. Schneider, R. Schurig, F. Staufenbiel, R. Xiang, FZD, Dresden, Germany,
T. Kamps, J. Rudolph, M. Schenk, BESSY, Berlin Germany,
G. Klemz, I. Will, MBI, Berlin, Germany

Abstract

A radio frequency photo injector with a superconducting acceleration cavity (SRF gun) for installation at the Radiation Source ELBE was developed within a collaboration of BESSY, DESY, FZD, and MBI. Beside the operation at ELBE, the SRF gun together with its diagnostic beam line is an excellent test bench for extended studies and improvements of this new and promising injector type. The gun cryostat, the electron diagnostic beamline, and the driver laser with optical beamline were installed in summer and fall 2007. In November the first beam was produced. It will be reported on the experience gained at the first phase of commissioning. Results of rf and beam parameter measurements with Cs₂Te photo cathodes are presented.

INTRODUCTION

In the status report presented at the FEL conference 2007 [1] we reported on the tests of the 3½-cell cavity in the vertical cryostat at 1.8 K, the assembly of the cryomodule of the superconducting radio frequency (SRF) gun and its installation in the ELBE accelerator hall. The first cool-down was successfully carried out in August 2007. Since that time the installation and commissioning of all other systems have been completed: the rf system was installed, the UV driver laser was delivered by MBI and tested, and the optical components of the laser beamline were installed and adjusted. The two weeks of the autumn shut-down of ELBE in October 2007 were spent to complete the installation of the diagnostic beam line. End of October, the gun was cooled down for the second time. After that the first accelerated beam could be produced on November 12, 2007. The electrons were extracted from a Cu photocathode. The time until end of 2007 was spent for commissioning and test of the diagnostic beamline components. In March 2008 the cathode transfer system was mounted and the first set of cesium telluride photo cathodes for the gun was produced. Since May 2008 the gun has been operated with these cathodes.

All the time since the first cool down has been used to gain operation experience, to optimize the installation and

the control systems, as well as to perform measurements mostly devoted to the RF properties and the beam parameters of the SRF gun. Since November 2007 the gun was operated for about 500 h without serious problems parallel to the user operation of the ELBE accelerator. The average current was mostly about 1 µA and always less than 10 µA due to radiation safety restrictions. During the beam time the acceleration gradient was always 5 MeV/m which belongs to 15 MV/m peak field in the cavity and about 7 MV/m at the cathode. The liquid helium consumption was about 5 W. A 30 % higher gradient seems possible but has not been tested up to now. Most of the measurements are preliminary and need a cross check which could not be performed during this operation period.

DESCRIPTION OF THE SRF GUN

Figure 1 shows the design of the SRF gun cryomodule. The module comprises the 3½ cell superconducting niobium cavity in the centre of the cryomodule. The cavity is welded into the He tank. On the right side in the half-cell the photo cathode is placed. The photo cathode is normal conducting and isolated from the Nb cavity by a vacuum gap. Its body is made of Cu with a Mo tip. On the front surface of the tip the Cs₂Te layer is deposited. A special support system holds and cools the photo cathode with liquid nitrogen. On the left side on the end tube of the cavity the HOM couplers and the flange for 1.3 GHz main power coupler can be seen. The cavity has two tuners, one for the three TESLA cells, and one for the half-cell. The large vessel in the upper part of the module is the storage for the liquid nitrogen. Two circular tubes deliver the liquid N₂ to the cryogenic shield. Between cryogenic shield and the vacuum vessel, a magnet shield is located. More details of the cryomodule design are published elsewhere [2]. The cryomodule is now installed in the ELBE hall and connected to the ELBE helium plant via the He port on the top. A photograph of the installed SRF gun module is shown in Fig. 2.

The use of semiconductor photo cathodes like Cs₂Te requires a cathode transfer system, in which the cathodes can be manipulated and stored in ultra-high vacuum. Its design is presented in Fig. 3. The system consists of three vacuum chambers: the transfer chamber (left), the lock (middle), and the transport chamber (right). In the system a movable carrier for 6 photo cathodes is located. One of the two manipulators is for the movement of the carrier, and the second serves for the exchange of the photo cathodes in the gun. A second similar transfer system

* We acknowledge the support of the European Community-Research Infrastructure Activity under the FP6 "Structuring the European Research Area" programme (CARE, contract number RII3-CT-2003-506395) and the support of the German Federal Ministry of Education and Research grant 05 ES4BR1/8.

[#]j.teichert@fzd.de

exists in the photo cathode preparation lab. In the transport chamber, which can be dismantled, the cathodes are brought from the preparation lab to the SRF gun.

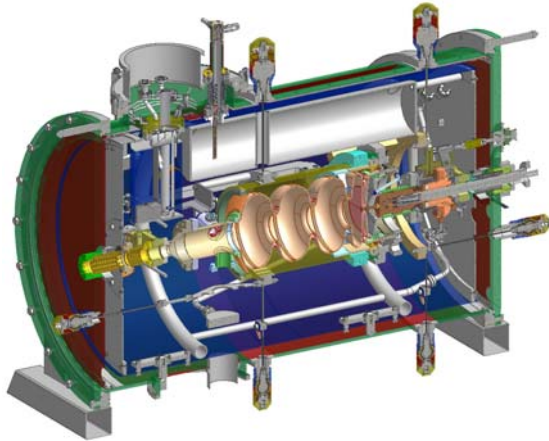

Fig. 1: Design of the SRF Gun cryomodule.

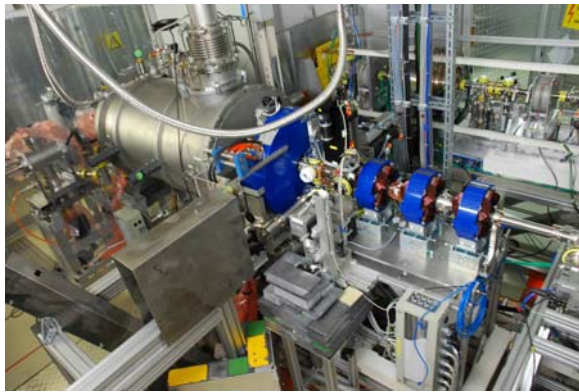

Fig. 2 : Photograph of the SRF gun in the ELBE accelerator hall.

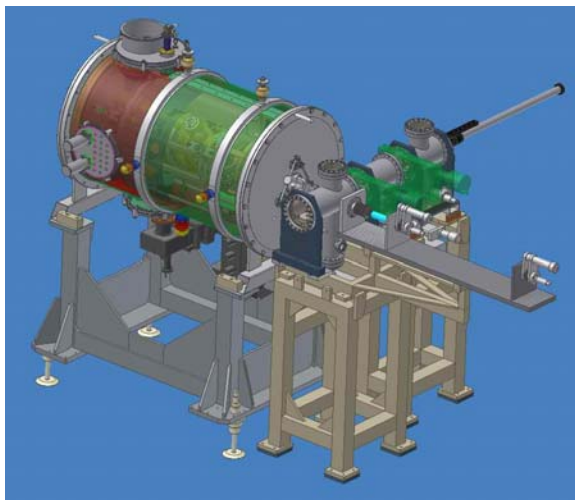

Fig. 3: Design of the photo cathode transfer system.

RF MEASUREMENT

The first cool-down of the SRF gun took place in August, 2007. For cooling and filling with liquid nitrogen

two days were needed. Then the cavity was cooled down with He gas (10 K) for about 24 h. After a break in which the two ELBE modules were cooled with He gas the tank was filled with liquid He. Finally, the tank was pumped to 30 mbar in order to get the working temperature of 2 K. Pressure stabilization is performed with cold compressors for all three cryostats of ELBE together using a pressure sensor near the first ELBE cryomodule. During the cool-down, the frequency of the π -mode (acceleration mode) was monitored as it is shown in Fig. 4. For the frequency shift from RT to 2 K a value of 2.02 MHz was found which is equal to the shift of TESLA resonators in the ELBE cryomodules. Unfortunately, the pre-stress adjustment of the SRF gun tuners was wrong. Thus, the final frequency obtained is about 400 kHz higher than expected.

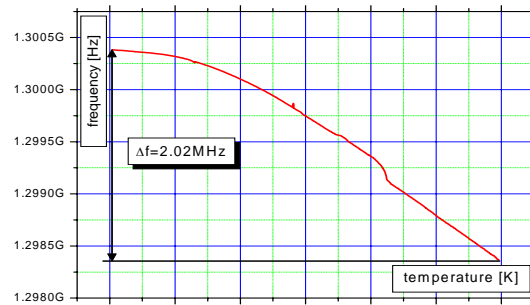

Fig. 4: Cool-down curve showing the cavity resonance frequency versus temperature.

Due to the weak coupling of the cavity the quality factor (unloaded Q) cannot directly measured. One way is to determine the additional He consumption caused by the RF power losses. The SRF gun cryostat has an electrical heater in the helium tank. For constant liquid He input flow and level in the cryostat the change of the heater power is a measure of the RF heat dissipation. These values were measured as function of the acceleration gradient which is obtained from the calibrated pick-up antenna in the cavity (see Fig. 5).

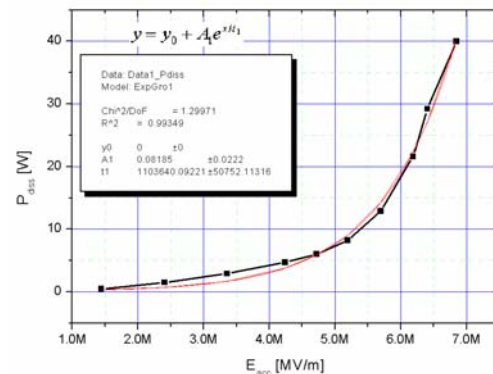

Fig. 5: RF power dissipation vs. gradient.

For the Q versus E_{acc} curve the results in Fig. 6 are obtained. The red curve in the figure shows the

corresponding radiation level due to the field emission in the cavity. It is obvious that the drop down of Q_0 is connected to field emission.

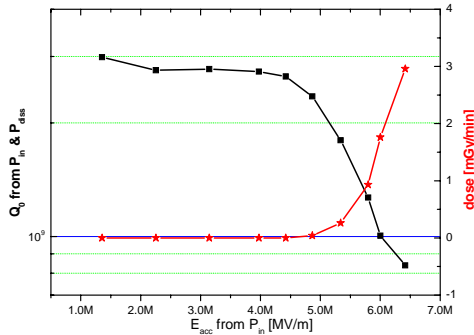

Fig. 6: Quality factor Q_0 versus acceleration gradient.

In order to measure the Lorentz force detuning of the SRF gun cavity, a network analyzer (NWA) was used as a driver unit for the klystron amplifier. To increase the cavity field, the output power of the NWA was raised in steps of 1dB while the gradient was calculated from the calibrated pickup voltage. The achieved typical transmission plots are shown in Fig. 7. For the quadratic dependence of the frequency shift $\Delta f = a E_{acc}^2$, the factor $a = -5 \text{ Hz}/(\text{MV}/\text{m})^2$ was found, which is about three times larger than that for TESLA cavities [3].

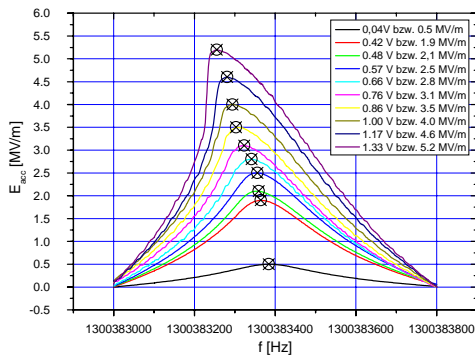

Fig. 7: Measurement of the cavity resonance curve (gradient vs. frequency) for increasing input power.

DRIVE LASER

In order to fulfill the requirements of the SRF gun specifications, a UV laser system with two channels has been developed by MBI. The first channel will deliver laser pulses with 13 MHz repetition rate and 5 ps pulse length. For the second channel the maximum pulse rate is 500 kHz and the pulse length 15 ps. The two channels have different oscillators, but jointly used amplifier and UV conversion. At present, the 500 kHz channel is installed and used for the experiments. The frequency-quadrupled Nd:YLF system for CW operation consists of a mode-locked oscillator with 26 MHz, a regenerative amplifier, and a two-stage frequency conversion (LBO and BBO). The Pockels cells in the amplifier allow

variable repetition rates up to 500 kHz of the output pulses. For 125 kHz and 2 kHz (diagnostic mode) the maximum pulse energies measured at 263 nm are 0.8 μJ and 50 μJ , respectively. A bunch charge of 1 nC requires 0.5 μJ pulse energy for a typical quantum efficiency of 1%. The laser has a Gaussian temporal beam shape with a width of 15 ps FWHM.

In the first operation period of the gun with the Cu photo cathode the spatial shape was also Gaussian with a spot diameter of about 1.3 mm FWHM. For the present measurements the laser beam spot is enlarged changing the telescope on the laser table. Then the beam is cut with an aperture to obtain a circular flat top profile. A picture of the laser spot (virtual cathode) is shown in Fig. 8. The diameter of the spot is 2.7 mm. The optical transport system comprises four lenses, five dielectric mirrors, a beam splitter (virtual cathode) near the input port of the gun, and one metallic mirror inside the vacuum tube. The last dielectric mirror is remote controlled and used for laser positioning onto the cathode or scanning for local Q.E. measurements. With the virtual cathode the shape and position of the laser spot are monitored by means of a CCD camera and a position sensitive detector. A movable mirror in the electron beamline and a CCD camera provide a view onto the cathode. Together with a special luminescence cathode the laser beam was adjusted.

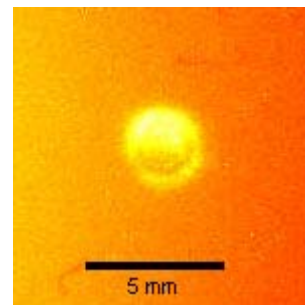

Fig. 8: CCD camera image of the laser spot at the virtual cathode. The spot diameter is 2.7 mm.

PHOTOCATHODES

A Cu photo cathode was mounted into the cavity during the assembly of the cryomodule. During the first commissioning phase of the gun this cathode was used. Its quantum efficiency was very low, about 10^{-6} . However, an electron beam could be produced and observed on YAG screens.

After installation of the cathode transfer system, the first set of Cs_2Te photo cathodes was produced in the preparation lab at FZD. After preparation the cathodes had quantum efficiencies of $4 - 5 \times 10^{-2}$. The first cathode was in operation until the ELBE shut-down in June 2008. Now the second photo cathode is inserted in the gun. A local QE measurement was carried out just after insertion. Figure 9 shows the measured Q.E. distribution. Whereas the local fluctuations of about 20% are rather good, the overall QE of the photo cathode was dropped down to about 1×10^{-3} . We assume that the reason is the bad vacuum of 10^{-8} mbar in the transfer system during the

insertion into the gun. The QE measurement was repeated every week without any further significant changes.

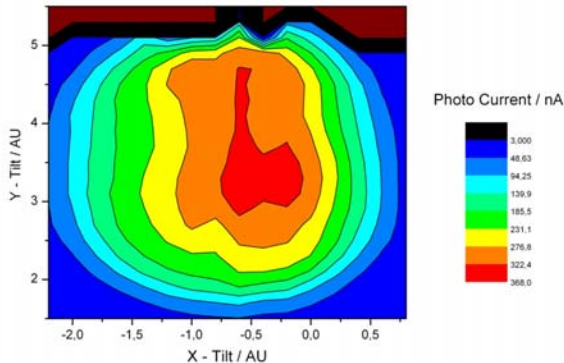

Fig. 9: Q.E. map of the Cs₂Te photo cathode in the SRF gun. Photo current measured in the Faraday cup.

DIAGNOSTIC BEAMLINE

The SRF gun can be characterized using the diagnostic beamline. The main components of this beamline were designed and manufactured by BESSY. A scheme of the setup is presented in Fig 10. Besides optical components for focusing and steering, the following diagnostics is available: Faraday cups and ICTs, beam position monitors, C bend magnet, slit mask emittance measurement, Cerenkov radiator with streak camera, and electro-optical sampling. A detailed description of the beamline is given in Ref. [4].

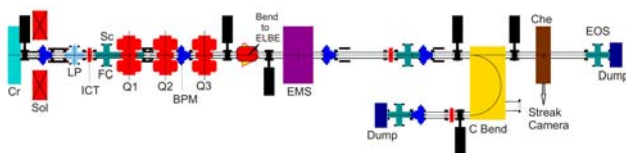

Fig. 10: Layout of the diagnostic beamline.

BEAM PARAMETER MEASUREMENT

The first step consists in a check of the laser spot position on the photo cathode and of the position of the gun solenoid. The laser spot have to be aligned with respect to the RF field axis of the cavity which can be proofed by an RF phase or gradient variation and an observation of the e-beam spot on the following view screen. Thereby the gun solenoid is switched off. The alignment is correct if the e-beam spot remains on its position. The position accuracy of the solenoid is checked in a similar way by varying its current.

In a Schottky scan the laser phase is varied with respect to the RF phase while measuring the accelerated bunch charge after the gun in a Faraday cup at constant laser pulse energy. This measurement has been carried out for different laser pulse repetition rates from 125 kHz down to 1 kHz with the same laser power of 20 mW for each

scan. Whereas the average current is about the same, the bunch charge is increasing with lower pulse rate. Figures 11 and 12 show the results for 125 kHz and 2 kHz, respectively. The phase values of the abscissa are related to 1.3 GHz, but the origin is arbitrary and given by the RF control system. In the 125 kHz case (Fig. 11) the curve is more pronounced. The increase of the current between -190° and -170° belongs to the zero-crossing point of the RF ($\phi_{laser} = 0^\circ$). The slope is determined by the laser pulse length. For the operation of the gun the phase range between -180° and -110° can be used. Although not of interest for operation, the three peaks at -100°, -75°, and 0° have a physical nature. Simulations show that they belong to bunches which are created in one RF period, partly decelerated, and again accelerated and extracted out of the cavity in the following RF period. For the phase range from 30° to 180° which is not shown we measured the dark current of about 5 nA only. A comparison between 125 and 2 kHz shows the space charge effect which smoothes the curve structure at higher bunch charges.

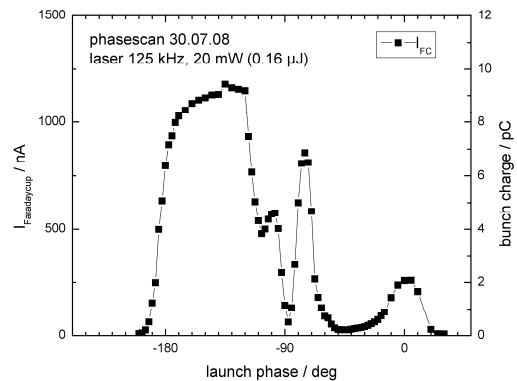

Fig. 11: Schottky scan at 125 kHz and 20 mW.

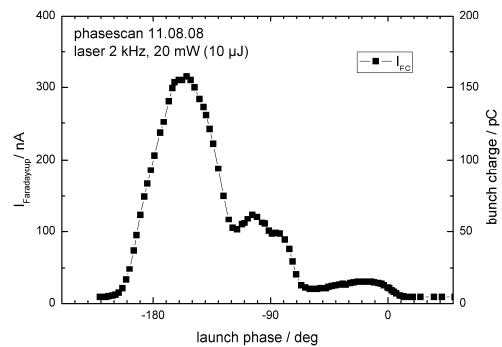

Fig. 12: Schottky scan at 2 kHz and 20 mW.

The beam energy and energy spread are measured using the c-bend magnet in the diagnostic beam line. The screen 4 in the straight section and the screen 5 after the magnet have the same optical distance from the gun. Thus, the image on screen 5 is the convolution of the beam spot of screen 4 with the beam energy distribution. The beam

energy and the rms energy spread as a function of laser phase are shown in Fig. 13 and 14. The measurements are performed with a laser pulse rate of 50 kHz and laser pulse energy of 0.4 μJ , which corresponds to a bunch charge of about 15 pC. The optimum phase window obtained from the maximum energy and minimum energy spread is from -180° to -160° .

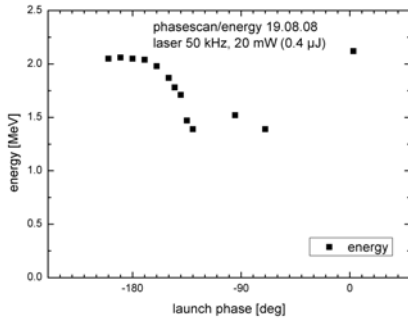

Fig. 13: Energy as a function of laser phase.

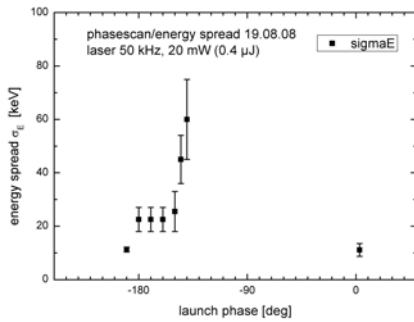

Fig. 14: The rms energy spread as function of laser phase.

The transverse emittance measurements presented in the following have been carried out with the solenoid scan method. For these measurements the gun solenoid and the screens 1 and 2 have been used. Between the solenoid and the screens there is only a drift space of 38 cm and 170 cm, respectively. The quadrupoles in between were not used. The magnetic axial field distribution of the solenoid was precisely measured. Thus the focal strength dependence on the excitation current I can be calculated. The measured beam size $\sigma_{x,y}^2$ on the screen is a parabolic function in I^2 containing the phase space ellipse parameters. From a quadratic fit these parameters and the emittance can be determined. It is well known that the solenoid/quadrupole scan method is not suitable for space charge dominated beams. Nevertheless, this method has been applied for first preliminary measurements. Later, when the development of the analysing tools is finished, the slit mask method will be used.

In order to establish the operation phase of the gun, the transverse emittance was measured as a function of laser phase as it is shown in Fig. 15. The bunch charge was 1 pC and the beam size was measured on screen 1 and 2, as well as in x- and y-direction. Considering also the results of the Schottky scan, energy and energy width measurements the laser phase is set to -160° . For this laser

phase the transverse emittance as a function of bunch charge has been measured. The result is shown in Fig. 16. The data analysis has been carried out for the second screen only. It requires less focusing and thus a lower space charge effect is expected.

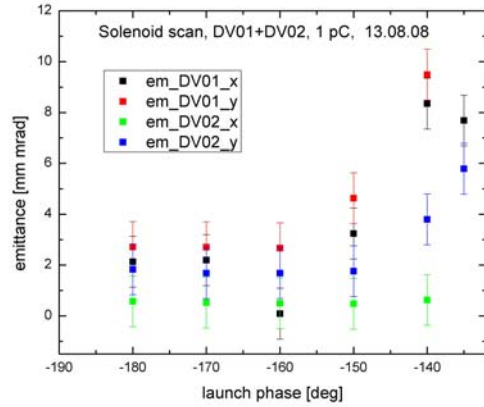

Fig. 15: Normalized transverse emittance as function of laser phase for 1 pC bunch charge.

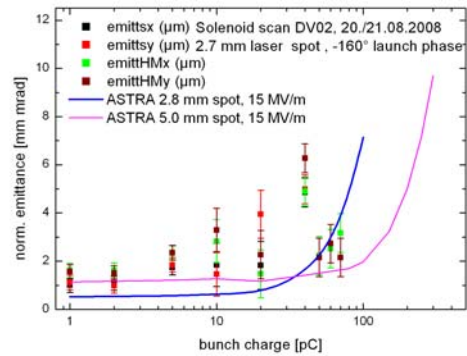

Fig. 16: Normalized transverse emittance as function of bunch charge for -160° laser phase and 2.7 mm laser spot, as well as comparison with ASTRA simulation (15 MV/m peak field, 2.8 mm and 5 mm circular flat top laser spot, optimized phase and cathode position).

For lower bunch charge the measured transverse emittance is between 1 and 2 mm mrad. At about 40 pC the values start to increase. Measurement could be performed up to 80 pC. The results are in good agreement with an ASTRA simulation for the same RF gradient (15 MV/m peak field) and laser spot size (2.8 mm diameter). Here the limit is 100 pC caused by the increasing space charge at the given gradient. The simulation also shows that for a larger laser spot (5 mm) the limit can be shifted to 200 – 300 pC. Measurement under these conditions will be carried out in near future.

SUMMARY AND OUTLOOK

A SRF photoinjector has been installed at the ELBE linac in summer 2007. The commissioning phase has been started and will be continued until October 2008. It is intended to deliver beam to ELBE in 2009 after a correction of the pre-tuning and the installation of a connection beamline to ELBE. In parallel the gun will be a test bench for further SRF injector studies.

REFERENCES

- [1] J. Teichert, et al., "A Superconducting RF Photo-Injector for Operation at the ELBE Linear Accelerator", Proc. FEL 2007, Novosibirsk, Russia.
- [2] A. Arnold, et al., "Development of a Superconducting Radio Frequency Photo Electron Injektor", Nucl. Instr. and Meth. A 577, 440 (2007).
- [3] B. Aune, et al., "Superconducting TESLA Cavities", Phys. Rev. Special Topics AB 3, 092001 (2000).
- [4] T. Kamps, et al., "Setup and Commissioning of the Diagnostics Beamline for the SRF Photoinjector Project at Rossendorf", Proceedings of EPAC 2008.