

# **The CFHT MegaCam filter, shutter and roll pitch mechanisms.**

S. Aune, O. Boulade, X. Charlot, P. Abbon, P. Borgeaud, P.H. Carton,  
M. Carty, J. Da Costa, D. Desforge, H. Deschamps, D. Eppellé,  
P. Gallais, L. Gosset, R. Granelli, M. Gros, J. de Kat, D. Loiseau,  
J.L. Ritou, J.Y. Roussé, P. Starzynski, N. Vignal, L. Vigroux

**Département d'Astrophysique, de physique des Particules,  
de physique Nucléaire et d'Instrumentation Associée,  
Commissariat à l'Energie Atomique, 91191 Gif-sur-Yvette FRANCE**

## **ABSTRACT**

MegaCam is an imaging CCD camera with a 1 square degree field of view for the new MegaPrime prime focus of the 3.6 meter Canada-France-Hawaii Telescope. This CCD camera is fixed on an aluminum structure, called Camembert for its shape, housing a shutter, a filter system and a roll pitch system to tune the CCD mosaic plane. The shutter is made with 1 meter diameter honeycomb half disks that rotates to covers or exposes the CCD mosaic. On this shutter a calibration source is fixed to monitor the CCD and its electronics. The filter system is made of a jukebox with a capacity of eight 30 cm square filters and of a loading arm to place them under the field of view. The instrument was delivered to the CFHT observatory on June 10, 2002 and first light is scheduled in October 2002.

**Keywords:** Wide field camera, filter, shutter, metrology.

## **1. INTRODUCTION**

MegaCam<sup>1,2</sup> is an imaging camera<sup>3</sup> with a 1 square degree field of view for the new MegaPrime<sup>3</sup> prime focus of the 3.6 meter Canada-France-Hawaii Telescope<sup>4</sup>. This instrument will mainly be used for large deep surveys ranging from a few to several thousands of square degrees in sky coverage and from 24 to 28.5 in magnitude. The camera is built around a CCD mosaics made of 40 large thinned CCD. The camera is fixed on a structure housing a shutter, a filter system and a roll pitch system to tune the CCD mosaic. This paper will describe each sub system (Camembert, roll pitch, shutter, and filter) and present the tests done to check their performance.

## **2. CAMEMBERT STRUCTURE**

The Camembert is the name of the main structure of the instrument: it holds the CCD camera in position with the Roll pitch inserted and it contains the shutter and filter system. It will be mounted on the Focal Stage Assembly<sup>5</sup> (FSA to be delivered to the CFHT by the Herzberg Institute of Astrophysics), itself fixed on the top of the prime focus structure of the telescope (figure 1). The Camembert diameter is 1.2 meter, it is 120 millimeters thick and composed of three parts: the body, the top plate and the cover. The Camembert parts are machined in Fortal aluminum alloy, which possesses a high strength and good machining behavior. To minimize the effect of light reflections all these parts are black anodized, and to avoid light pollution there are assembled together with a joint.

### **2.1 The Camembert top plate**

The top plate supports the cryostat and the cryogenic helium dispatching system. Since no weight is on the east side of the camembert, and to allow a easy access to the moving parts of the filter system, this plate covers only a bit more than half of the west side of the camembert (figure 2). The top plate has two holes, a small one for the access to Filter Holder Blocking System (see section 5), the other with a short centering to fit the CCD camera.

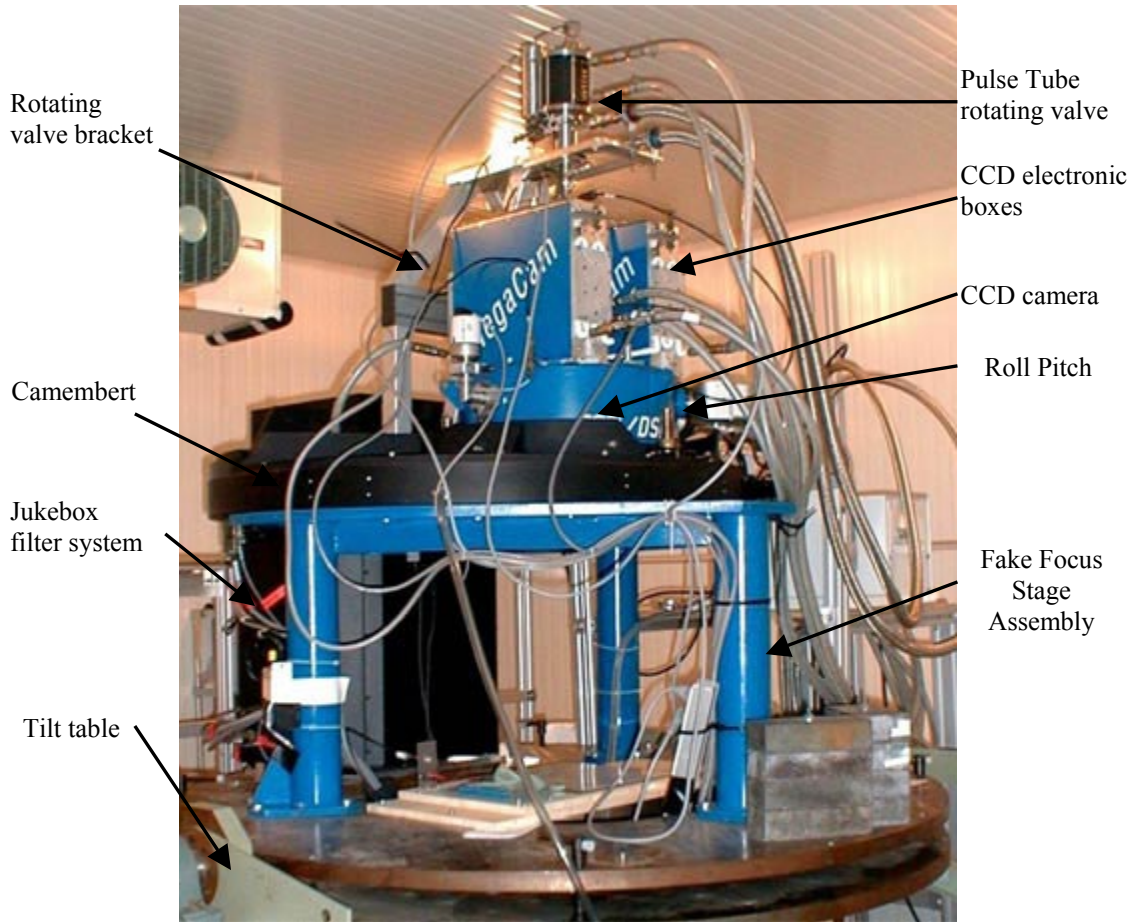

figure 1. Megacam instrument during the tests on the tilt table

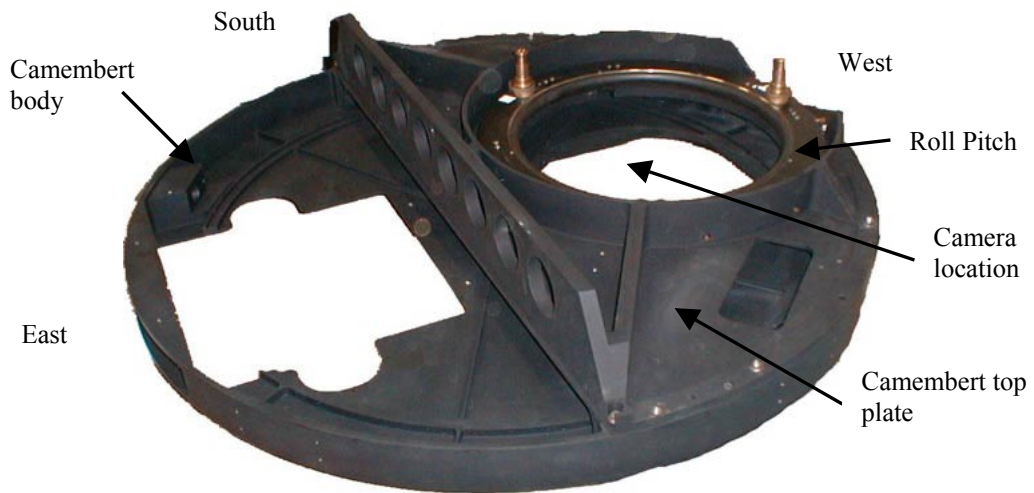

figure 2. View of the Camembert structure

On the internal face of the plate we find the filter guiding system: the slide-rail (see section 5). On the external face the bracket of the cryogenic rotating valve is attached. We have also machined on this face a hole (with a cover) to permit a maintenance access to the Filter Holder Blocking System. To handle this plate, three threaded holes, with removable

lifting eye, have been done. The positioning of the top plate is ensured by two holes that fit with the locating studs of the Camembert body.

The main requirement is on the mechanical deformation of the top plate. The static deformation of this plate (mainly due to the weight of the cryostat) at the telescope zenith position is compensated by the roll pitch system. The differential deformation, from one telescope position to another for the whole MagaCam instrument (camembert, roll pitch and CCD camera), should not exceed  $\pm 20 \mu\text{m}$  at the edges of the CCD mosaic, that is a tilt of  $\pm 22$  arc-second. This requirement imposes us to have several reinforcements while the plate should be as light as possible. Those reinforcements act as weight path to bring the load towards the three actuators of the FSA. To achieve the lightest plate with the given requirement on the deformation a finite elements model was made (figure 3).

## 2.2 The Camembert body

The body of the Camembert is made of the outer ring of the Camembert and of the bottom plate, both machined in a single piece. The outer ring ( $\Phi = 1200$  mm) is reinforced to bring the load to the FSA. It has several blind threaded holes to allow the bolting of the top plate and opening holes to bolt the whole Camembert to the FSA support plate. To allow the positioning and the repositioning on the FSA, two locating studs are implanted. A hole, visible on the west face of the ring, allows to have the roller screw of the loading arm out for an external fixation of the motor.

On the East side of the body an opening is done to allow the passage of a fake filter for the alignment between the jukebox and the filter slide-rail. This opening is closed by a plate on which stands the inductive magnetic reading device to scan the filters. From the center to the periphery of the body reinforcements have been made for the fixation of the shutter motor situated beneath the Camembert

## 2.3 The Camembert deformation tests

The Camembert was mounted on a fake FSA itself mounted on the swiveling bench (figure 4). Three mechanical sensors were mounted under the fixation flange of the camera. The bench was tilted in the 4 directions (N-S, E-W) from  $0^\circ$  to  $60^\circ$  by step of  $15^\circ$ , which gave us the deformation values without load. Then a fake camera load (same weight and center of gravity) was fixed on the Camembert. Again we tilted the bench, two sets of measurements were made. Figure 5 shows the result in East-West orientation where the values are maximum. The maximum tilt is around 15 arc-second for  $60^\circ$  West.

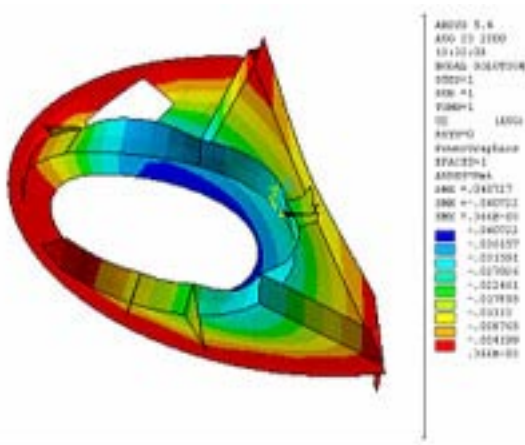

figure 3. Finite element model of the top plate



figure 4. Camembert Deformations test on a tilt table

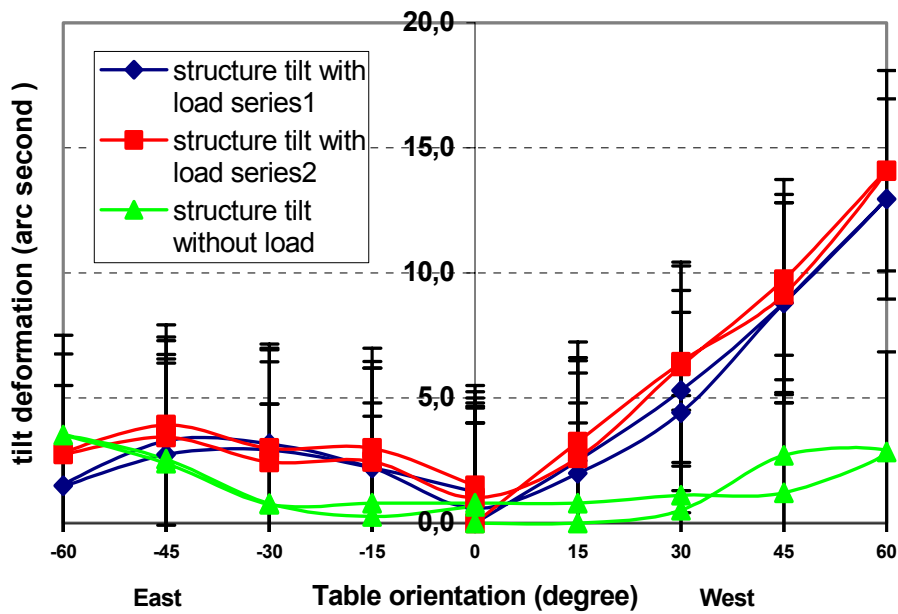

figure 5. Result of the deformation tests of the Camembert

#### 2.4 The MegaCam instrument focal plane tilt tests

The CCD mosaic focal tilt versus inclination was measured with the whole MegaCam instrument (Camembert, filter, shutter, roll pitch, camera and electronics, and related cables) mounted on the swiveling bench in a climatic room with a stable temperature of 10°C (figure 6). The CCD temperature was 153 K and the cryogenic system was active during the test. Three optical sensors (STIL-CHR150) were mounted under the window of the camera, to look at the surface of the CCD mosaic, on a structure calculated and made to have less than 2 microns relative deformation when the bench was tilted. The 3 sensors heads were connected with optical fiber to a control unit containing the source of white light and the optical system of analysis (spectrophotometer, CCD, and DSP). The resolution of the sensor is 0.3 micron in z direction. Figure 6 shows the sensors under the CCD mosaic.

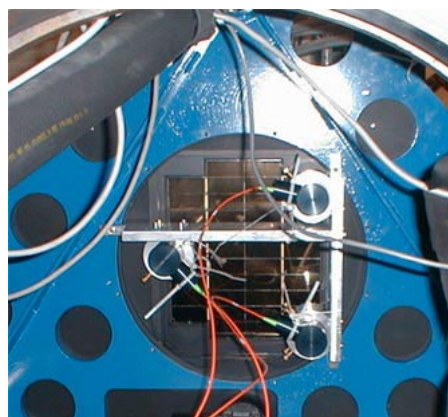

figure 6. Instrument Deformations test on a tilt table and Optical sensor under the CCDs mosaic

We measured the distance of the focal plane and the evolution of this distance with respect to the tilt of the instrument thus allowing us to calculate, with 3 points, the plane of the CCD mosaic at different angles having the zenith position for reference. The bench was tilted in the 4 directions (N-S, E-W) from 0° to 60° by step of 15°. Figure 7 shows the tilt of the focal plane of the instrument with an East-West tilt of the bench, the values stays within the specification except for 60° west inclination where we have 23 arc-second.

Also we have made images with the CCD camera of the spots of the three sensor (50 micron diameter) to check the lateral X and Y displacement and the Rz rotation of the CCD mosaic. The result showed a displacement under 5 microns per 15° angular displacement.

The frequency of measurements of the sensor (30 to 1000Hz) allowed us to look for possible vibration effect of the cryocooler (gas flow exchange at 7 Hz) on the CCD mosaic. The result showed no deformation impact related to the pulse tube functioning.

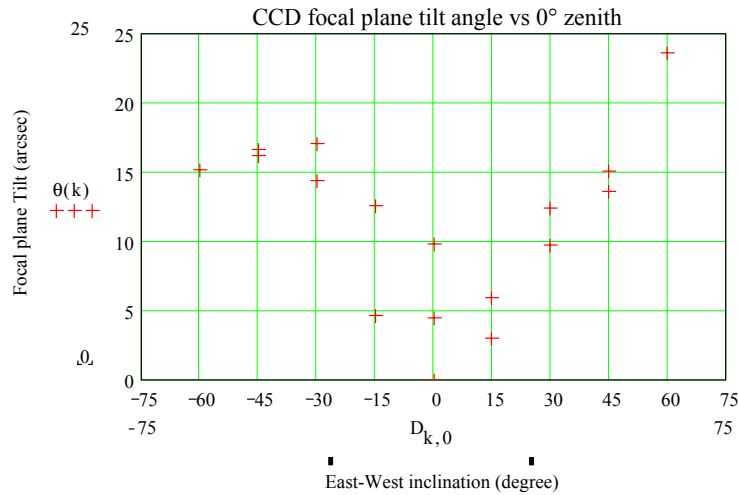

figure 7. **MegaCam Instrument focal plane tilt versus telescope orientation**

### 3. ROLL PITCH

#### 3.1 Roll pitch design

The goal of the Roll Pitch is to adjust the parallelism of the CCD mosaic with the telescope focal plane. It is mounted between the camera and the Camembert structure (figures 1 & 2). The large dimension of the CCD array ( $\phi = 320$  mm) with respect to the focal depth of the instrument ( $L = 120$  micron) imposes us this tuning with an adjustment better than 72 arc-second or  $0.02^\circ$ . This tuning of the Roll Pitch will be done during the first light of MegaPrime by making images and checking the quality on the corners of the CCD array. Once the Roll pitch is adjusted it will be mechanically locked in position, this adjustment will be done once and for all.

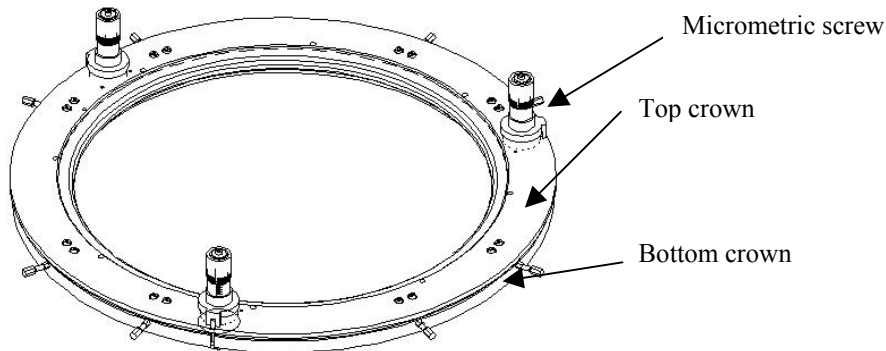

figure 8. **Roll Pitch design**

The Roll Pitch system is essentially composed of two crowns, three differential screws and several blocking screws. The bottom crown is fixed to the Camembert structure and the top crown holds the camera. The two crowns are maintained together by the three differential screws, the flexible coupling between the top and the bottom crown is obtained by three stacks of cup washers located on the differential screw position.

When the Roll Pitch system is tuned to its middle range the space between the top and the bottom crown is 4.5 millimeters and the differential screws maintain the cup washers stacks in prestress. The range of the adjustment is  $\pm 0.8^\circ$ . The adjustment displacement is obtained by regulating three micrometrical screws (figure 9). It produces a maximum displacement of  $\pm 2.56$  mm at the mosaic corners. The three screws are evenly positioned at a radius of 250 mm (with an angle of  $120^\circ$  between each other). The adjustment can be performed with a range of  $\pm 3.5$  mm with an accuracy of 5 micron on each screw.



figure 9. Mounting of the camera on the Roll Pitch

### 3.2 Roll pitch deformation test

To check the deformation of the roll pitch at different tilt values the system was tested with the tilt table with the fake camera load. The results were in the deformation budget, i.e. maximum of 5 microns lateral shift per  $15^\circ$  tilt. For the shift of the mosaic figure 10 shows a maximum 4 microns shift for  $15^\circ$  tilt when the bench is tilted around  $45^\circ$  to  $60^\circ$  East. When the bench reaches  $60^\circ$  East and comes back to  $45^\circ$  East the direction of the shift changes coming towards the initial position. For the tilt deformation of the focal plane the average value is 11 arc-second.

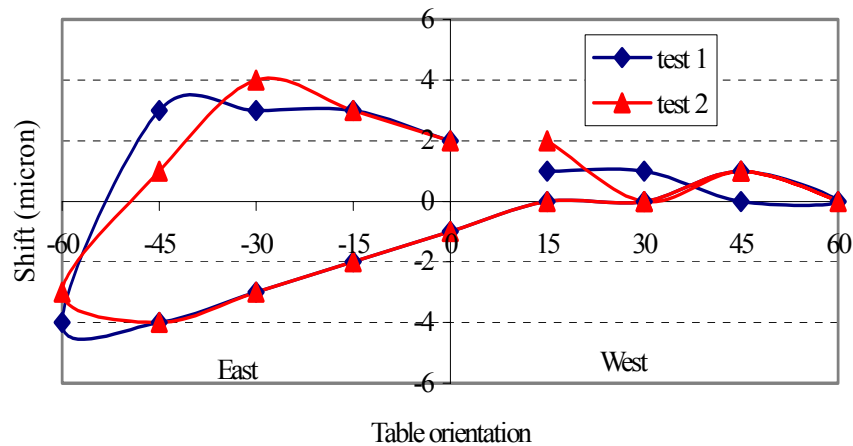

figure 10. Shift of the roll pitch between consecutive orientation

## 4. SHUTTER

### 4.1 shutter concept

The concept of the shutter is based on a balanced rotating Half Disk (HD) that covers or exposes the optical field. The rotation motion uncovers the field of view, waits for the wanted amount of time and then cover backs, in the same direction, the field of view. The exposure time can be written as:  $T_e = T_w + T_m$ .  $T_e$ : exposure time,  $T_w$ : waiting time (0 to infinite),  $T_m$ : minimum exposure time ( $T_m = 1,045$  s).

To ensure the uniformity of illumination of 1 % the angular speed is constant during the covering and the uncovering of the focal plane mosaic (figure 11). Since the shutter is balanced the exposure is uniform whatever the telescope direction. The shutter is equipped with a calibration source mounted on its topside and an optical exposure time measurement system apart of the shutter.

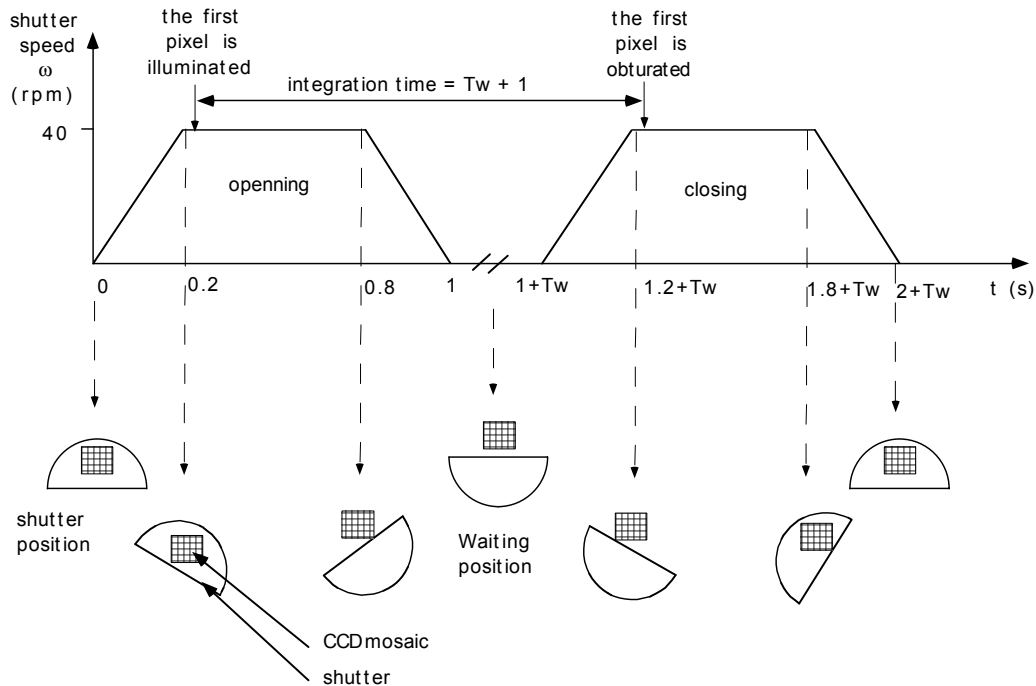

figure 11. Shutter movement

To obtain a minimum exposure time of 1 s, the shutter angular speed must be 40 rpm, with a reducing gear we obtain 4000 rpm for the motor angular speed. To obtain the uniformity of 1 % on the exposure time over the whole mosaic we need a tolerance of  $\pm 20$  rpm on the motor angular speed, this can be easily achieved. We have measured a uniformity of the angular speed better than 0.3%.

### 4.2 Shutter design

The Half Disk is made of a 4 mm thick aluminum honeycomb sandwich panel with flatness better than 0.1 mm. The panel is in black mat anodized aluminum. The choice of an aluminum honeycomb sandwich rather than composite is made to avoid moisture problems and a good static electrical discharge. A contact cam glued on the slice allows to have the initialization position of the shutter with respect to a sensor fixed on the West side of the Camembert (shutter closed). This contact will induce rubbing only in the beginning of the acceleration/deceleration zone (low speed), this means not in uncovering/covering of the mosaic (figure 12).

The HD is mounted on a stainless steel axis with a tungsten counterweight to obtain a balanced system. The ball bearing supporting the axis of the shutter is mounted in the center of Camembert body. The axis is coupled to the motor through a right-angle gear with a reducing factor of 100. Once everything is mounted the reducing gear and the motor can be easily dismantled from under the Camembert in case of troubleshooting.

The periphery of the shutter is mounted in a baffle. This baffle is composed of two part both black mat, one is directly machined in the Camembert body (figure 13), the other that covers the disk is mounted afterward. The baffle covers the course of the shutter ( $2\pi$ ) except in the Jukebox path (see section 5). The clearance between the HD and the baffle is reduced (0.8 mm) to obtain a light tight system. Four easily removable Teflon pods exceeding the shutter thickness by 0.2 mm are implanted on the shutter periphery prevent the disk of touching the baffle (figure 13).

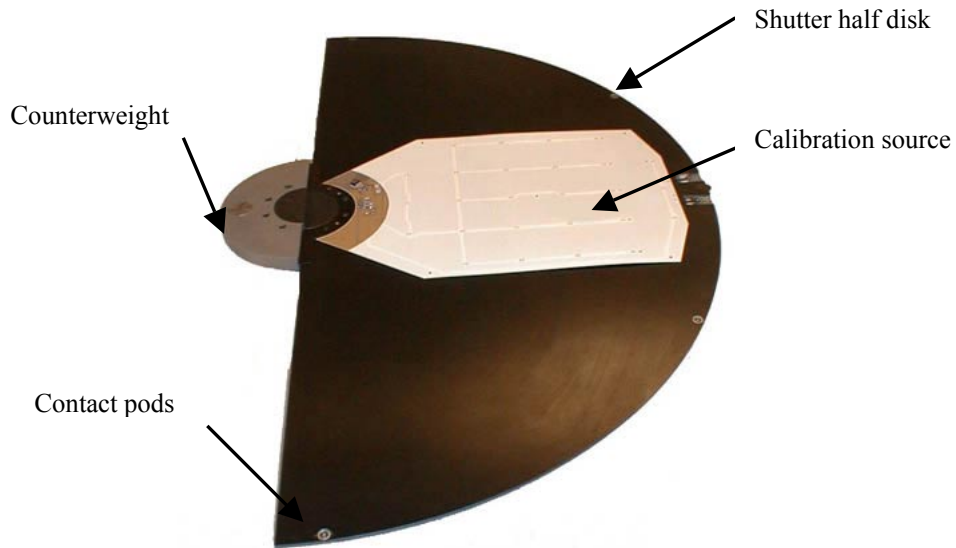

figure 12. Shutter view

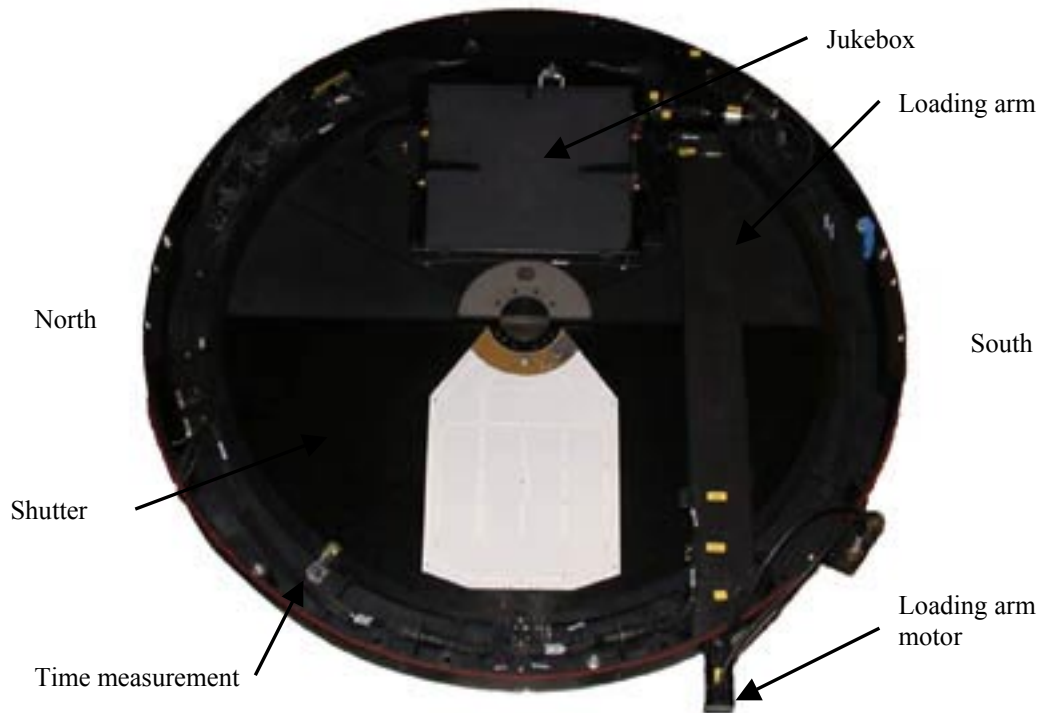

figure 13. Shutter mounted in the Camembert body



### 4.3 The shutter calibration source and exposure time measurement

For the exposure time measurement<sup>6</sup> a system is implanted in the top baffle for the emitter (infrared LED) and in the bottom baffle for the receptor. It is an optic system that induces no contact with the shutter and does not interfere with the CCD wavelength. The sensor is implanted on the guiding system at an angular position where the shutter is at a constant speed. Information is given each time the shutter passes before it, thus allowing to know the exact exposure time with an accuracy of 0.1 %.

A calibration source, made of an array of 26 LEDs fixed on a circuit, is mounted on the top surface of the shutter. This source allows an almost flat illumination of the CCD mosaic used to check the CCDs during setup and to monitor their evolution (figure 12). The electrical power and the signal command of the light calibration source are ensured by two pads attached on the half disk which are in contact with 4 spring mounted dowels when the shutter is closed in the initialization position.

## 5. FILTER MECHANISMS

The filter exchange system offers a capacity of 8 filters (30 cm x 30 cm). The change from one filter to another is remotely controlled<sup>6</sup>. The control must provide indication of which filter is in the optical path and an indication of the correct position. The fixed time to change a filter to another is no more than 105 seconds. The filter system is able to work whatever the telescope zenithal angle.

The Filter System is composed of two moving elements, a lift which moves a jukebox (JB) containing 8 filters and a loading arm (LA) that charges one of them. When a filter is required, the lift moves to put the corresponding jukebox slot at the level of the optical path. The lift motor encoder knows the slot position once an initialization is done on the Camembert to take in account the focusing done by the FSA. An inductive device verifies the filter identity. The loading arm then puts and maintains the filter in the optical path. If one filter is already in place, the jukebox is moved to this filter slot and the loading arm stores it.

The shutter path crosses the upper part of the lift path (figure 14: JB top position). Therefore, when a filter has to be changed the shutter must be closed and when the shutter has to be activated the jukebox lift must be in its observation position. Even though the positions of the shutter and of the lift are known with the motor coders, they are hardware secured through 2 sensors to avoid any crash.

### 5.1 The filter holder

The filters are mounted in filters holders (FH) made of two frames joined together in which the filter is held on a 5 mm periphery band. The FH is conceived to hold a filter of a thickness up to 15 mm. On each FH backside a small device (half a US quarter coin) that permits a magnetic identification is mounted. This magnetic device is coded on 64 bits.

To insure the position reproducibility there are, on the topside of the FH, two conic prints that will come in mechanical contact, in optical position under the CCD camera, with two cones located in the Camembert thus insuring the position reproducibility.

### 5.2 The Jukebox

The JB is composed of 8 slots in which the FH are stored. The JB is mounted in the lift through two irreversible recirculating roller screws. The motor is coupled to the roller screws through two right angle reducing gears with a reduction of 5. Both motor and reducing gear are reachable by the housing door. The lift is mounted on a plate fixed on the Base of the prime focus structure (figure 15).

Once all the needed FHs are stored in the JB a scanning of all the different slots is done to determine which FH is stored in each slot. This scan is done each time the JB housing door is opened, or each time the information is lost (current stop). This scan is done by moving the JB slot by slot in front of the magnetic reading device located in the lift shaft at the level of the optical FH position (a single scan is also done before loading any FH in optical position). To manually exchange a filter the JB must be in its lower position, the user must open the door of the JB housing, and then has an access to the backside of all the FHs.

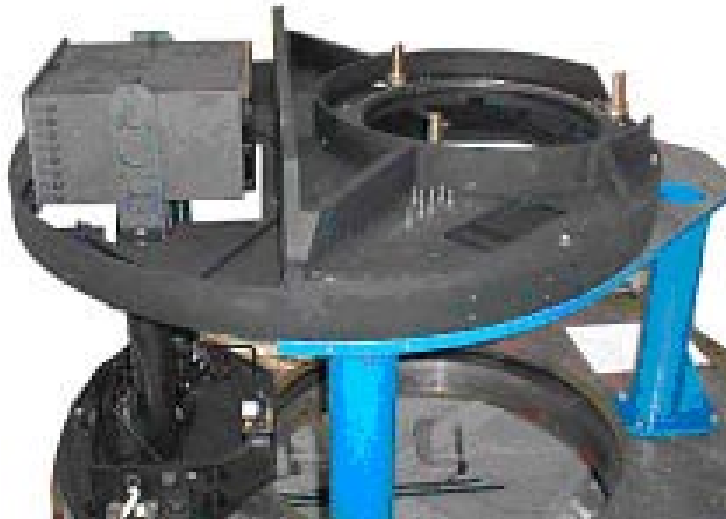

*figure 14.* **JB in the last filter loading position**

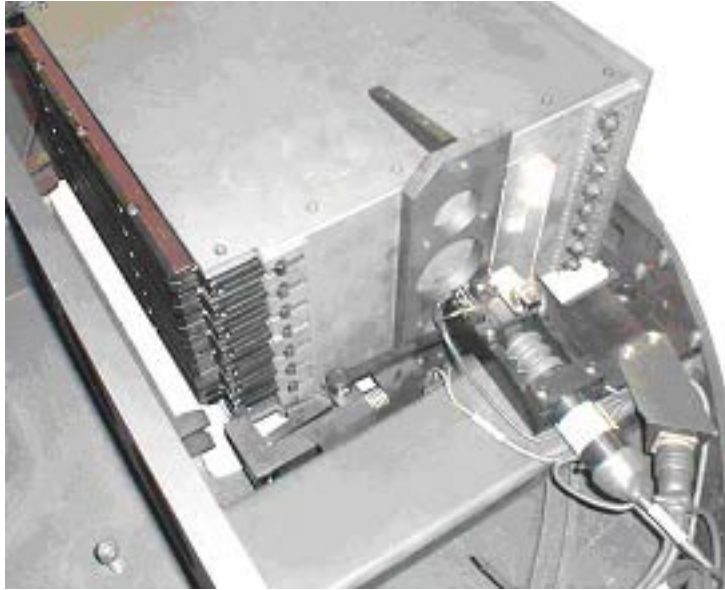

*figure 15.* **View of the jukebox with 8 filters**

### **5.3 The loading arm**

The loading arm is mounted on an irreversible recirculating roller screw that has a position accuracy of 40  $\mu\text{m}$ . The motor is mounted outside the Camembert body (figure 13).

On the LA there is a rocking latch that catches the FH from the JB. This rocking latch is normally in catch position due to a release spring and its opening is done with an electrical jack actuator fixed on the Camembert body (figure 16). This rocking latch is mounted on the loading arm in a second spring system (in the axis displacement) allowing, once the FH in optical position on the two cones, to put a load ( $F > 60$  Newton) in order to maintain the FH in position. Another identical load is obtained on the other side of the FH with a second electrical jack mounted in the Camembert body.



*figure 16.*     **Loading arm with Jukebox**

#### **5.4 The slide rail**

Two slide rails are mounted on the inner side of the Camembert Top Plate (figure 17). They are in black anodized aluminum coated with Nuflon. When a filter moves out of its jukebox slot it enters the slide rail and it is guided to its optical position right under the camera window.

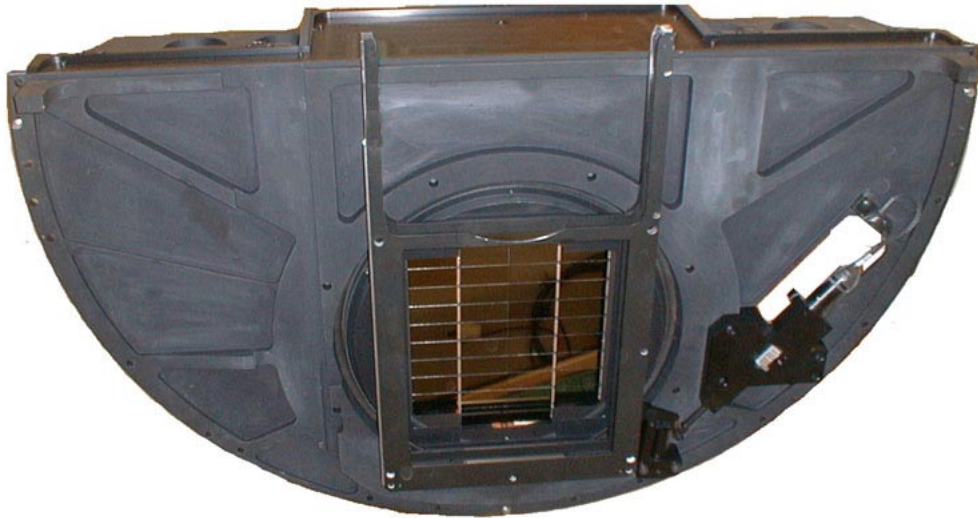

*figure 17.*     **View of the Camembert top plate with the slide rail and the CCD mosaic behind**

#### **5.5 The Filter system Tests**

The filter system has been tested on the tilt table in the climatic room with the entire MegaCam instrument assembled. We were able to load each filter whatever the tilt table orientation. The filter system is remotely control by a

Programmable Logic Controller. All the different cases of failures, with filters stuck at different location, were tested to check the reliability of the PLC codes, especially in case of power failure where the system has to come back to a safe initialization position.

## 6. CONCLUSION

The MegaCam Instrument was delivered to the CFHT in June 2002. It was installed in a laboratory and tested with the CFHT team, everything worked out nominally. The know-how was passed from the CEA team to the CFHT team for they will maintain and operate the instrument. The MegaCam instrument should be installed with the MegaPrime structure on the telescope on the beginning of September and have its first light by the beginning of October.

## REFERENCE

1. MegaCam home page <http://www-dapnia.cea.fr/Phys/Sap/Activites/Projets/Megacam/index.html>
2. O. Boulade et al., "MegaCam, the new Canada-France-Hawaii Telescope wide field imaging camera", in Instrument Design and Performance for Optical/Infrared Ground Based Telescopes, M. Iye and A. F. Moorwood, eds, Proc. SPIE **4841**, 2002.
3. S Aune et al., "The CFHT MegaCam 40 CCDs camera: design and integration", in Instrument Design and Performance for Optical/Infrared Ground Based Telescopes, M. Iye and A. F. Moorwood, eds, Proc. SPIE **4841**, 2002.
4. MegaPrime home page <http://www.cfht.hawaii.edu/Instruments/Imaging/Megacam/index.html>
5. J. T. Fitzsimmons et al. "Design and performance of the guide and focus sensor units and the focus stage assembly manufactured for the MegaPrime wide-field imager", in Instrument Design and Performance for Optical/Infrared Ground Based Telescopes, M. Iye and A. F. Moorwood, eds, Proc. SPIE **4841**, 2002.
6. J-Y Roussé et al., "The CFHT MegaCam control system: new solutions based on PLC, WorldFIP fieldbus and java softwares", in Instrument Design and Performance for Optical/Infrared Ground Based Telescopes, M. Iye and A. F. Moorwood, eds, Proc. SPIE **4841**, 2002.