

LUMINOSITY MEASUREMENT IN ATLAS

MAARTEN BOONEKAMP

CEA-Saclay

91191 Gif-sur-Yvette Cedex, France

E-mail: maarten.boonekamp@cern.ch

This contribution summarizes the method ATLAS intends to exploit to determine the LHC machine luminosity. The measurement is performed during dedicated runs, where elastically scattered protons are detected at very small angles, and the luminosity is extracted from the theoretically well known Coulomb cross-section. The same data are used to normalize a luminosity monitor, which then provides the instant luminosity during normal physics running. The physics method is described, as well as the experimental devices and the expected performance.

1 Importance of the luminosity measurement

For many measurements at the LHC (like cross-sections and branching ratios) the uncertainty on the integrated luminosity dominates the final result. One prominent example is the measurement of the Higgs boson properties. In the relevant mass range, the expected precision of the measurement of the $H \rightarrow ZZ^{(*)}$ decay probability is about 12% if one assumes the luminosity is known to 10%; this number improves to 6% when the luminosity is known to 5%. Other standard cross-sections, like inclusive W and Z production, provide important tests of QCD and factorization, and benefit from an accurate luminosity determination.

A precision of 5% is generally quoted to be a realistic goal using a combination of measurements obtained from LHC machine parameters and well-known QED processes, like $pp \rightarrow p + l^+ l^- + p$. The goal of the ATLAS experiment is a precision of 1% to 2% through the measurement of proton-proton elastic scattering in the region dominated by photon exchange.

2 Luminosity from elastic scattering in the Coulomb region

If one can detect elastically scattered protons at small enough angles, i.e in a $|t|$ -range sensitive to the Coulomb and nuclear interactions and their interference, then a measurement of the protons angular distribution provides a simultaneous determination of the luminosity, the total hadronic cross-section, the ρ -parameter and the proton nuclear slope. One can write:

$$\frac{dN}{dt} = L\pi (f_{QED}(t) + f_N(t))^2, \quad (1)$$

$$\sigma_{tot} = 4\pi\Im(f(t=0)), \quad \rho = \frac{\Im(f(t=0))}{\Re(f(t=0))} \quad (2)$$

where $f = f_{QED} + f_N$, f_{QED} is the well known electromagnetic amplitude, f_N is the

Figure 1. *Left*: the Roman pot device. *Right*: a simplified view of the detector geometry.

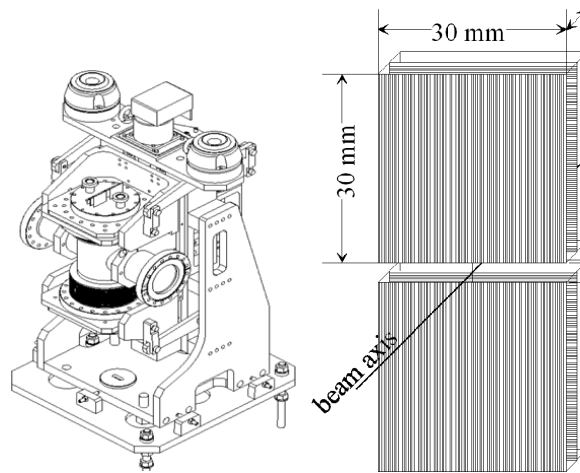

nuclear amplitude, and the second relation expresses the optical theorem. Hence, injecting the expressions for the electromagnetic and nuclear scattering amplitudes:

$$\frac{dN}{d|t|} = L\pi \left(\frac{-2\alpha_{QED}}{|t|} + \frac{\sigma_{tot}}{4\pi} (i + \rho) \exp^{-b|t|/2} \right)^2, \quad (3)$$

and the angular distribution $dN/d|t|$ gives access to L , σ_{tot} , ρ , and b . This method has previously been employed by the UA4 collaboration [1].

3 Experimental setup and expected results

The detection of forward protons relies on scintillator detector arrays, placed inside Roman pot devices at about 240 m from the interaction point (IP).

Two Roman pot stations are foreseen on each side of the IP, each holding a scintillator fibre tracker. A tracker comprises a trigger scintillator, an array of vertically staggered square fibres for x -position measurement, and a horizontally staggered array for y -position measurement.

ATLAS plans to use the Roman pots designed by the Totem collaboration [2], as displayed in Figure 1, and manufactured scintillator fibres for the trackers. The fibres have a section of $0.5 \times 0.5 \text{ mm}^2$, the total detector surface is $3 \times 3 \text{ cm}^2$, and its thickness is 5 mm. The intrinsic position resolution of the system is found to be $25 \text{ }\mu\text{m}$ in both coordinates.

Accessing the Coulomb region requires that the $|t|$ -acceptance of the system reaches a few 10^{-4} GeV^2 . This can only be achieved with dedicated machine optics (namely a very parallel beam, with $\beta^* = 2625 \text{ m}$), and assuming the beam can be approached by the trackers to about 10 times its transverse size at the detection point. The luminosity resulting of such optics is typically $L \sim 10^{27} \text{ cm}^{-2} \text{ s}^{-1}$.

Figure 2. Simulation of the angular distribution of elastically scattered protons, and results of a fit to Eq. 3.

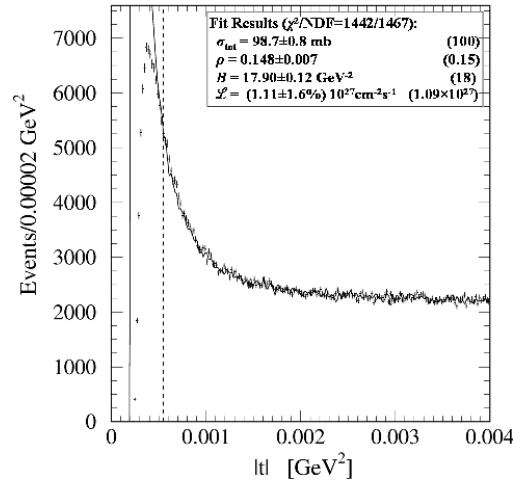

A Monte-Carlo simulation of the measurement was performed, and is illustrated in Figure 2. At this level, perfect machine optics were assumed, and no explicit background simulation was included. However, once the LHC operates reliably, the machine optics should be known sufficiently well not to become a large source of uncertainty. In addition, considering the low luminosity at which the measurement is performed, thus the relatively favourable machine background conditions, a more complete result should not differ significantly. Under the above assumptions, a luminosity precision better than 2% seems reachable. Simultaneously, the total cross-section is measured to 1%, the ρ -parameter to 0.5%, and the nuclear slope to 0.7%.

4 Luminosity transport and monitoring

The above system allows for a precise luminosity measurement at $L \sim 10^{27} \text{ cm}^{-2} \text{ s}^{-1}$, and the result is still to be extrapolated to normal running conditions.

ATLAS intends to implement a Cerenkov detector at high rapidity, covering $5.4 < |\eta| < 6.1$. This detector, called LUCID, is composed of 1.5 m long projective tubes, of diameter 1.2 cm, and located at about 17 m from the IP. This system collects the light emitted by particles crossing its active volume. Because of its geometry, it is able to discriminate efficiently between primary particles coming from the IP, aligned with the tubes and crossing most of the active volume, and secondary particles not aligned with the tube axis. The discriminating power is illustrated in the left part of Figure 3.

LUCID is a particle counter whose response is expected to be proportional to the number of particles produced at the IP. This is confirmed in the right part of Figure 3, where the response as a function of the number of interactions per crossing is shown. As can be seen, excellent linearity is observed from one interaction

Figure 3. *Left* : Light yield for minimum ionizing particles crossing LUCID, as a function of their incidence angle. *Right* : response of the system as a function of the number of interactions per bunch crossing.

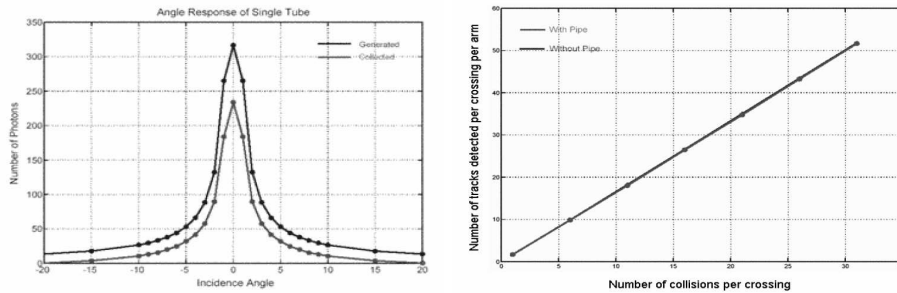

per crossing (which corresponds to very low luminosities) to 25-30 simultaneous interactions, corresponding to high luminosity physics running conditions. Thus, normalizing LUCID's response to the absolute luminosity measured during the special runs and scaling to the response observed during physics running provides an adequate instant luminosity determination.

5 Perspectives

The current performance estimate relies on realistic detector assumptions, but assumes perfectly known machine optics, and does not include explicit background simulations. Including the above effects and quantifying their impact is in progress.

The presentation given here is obviously very short and does not do justice to the amount of work involved. Full details of the system design at this stage can be found in [3].

Acknowledgements

I am reporting the results of the ATLAS effort on luminosity determination. This work is lead by Michael Rijssenbeek, and prominent contributors are Ilias Efthymiopoulos, Angeles Faus-Golfe, Per Grafstrom, Maurice Haguenaer. The complete list of collaborators and responsibilities can be found in the ATLAS Luminosity Letter Of Intent.

References

1. UA4 Collaboration, Phys. Lett. **B198** (1987) 583.
2. TOTEM Collaboration, Technical Design Report, CERN/LHCC/2004-002.
3. ATLAS Collaboration, Luminosity Letter of Intent, CERN/LHCC/2004-010.