

# Six axis position sensor: principle and calibration

J.C. Barrière\*, O. Cloué, B. Duboué, M. Fontaine, V. Gautard<sup>†</sup>, P. Graffin, C. Guyot, G. Jiolat, P. Perrin, P. Ponsot, J.-P. Schuller, P. Schune, Y. Reinert

CEA-Saclay  
DAPNIA

\*Phone: +33-1-69-08-68-54, Fax: +33-1-69-08-63-01, [barriere@dapnia.cea.fr](mailto:barriere@dapnia.cea.fr)

<sup>†</sup>Phone: +33-1-69-08-45-96, Fax: +33-1-69-08-63-01, [gautard@dapnia.cea.fr](mailto:gautard@dapnia.cea.fr)

In the Atlas experiment, the geometry of the muon spectrometer has to be known with 30  $\mu\text{m}$  of accuracy in translations and 200  $\mu\text{rad}$  in rotations for displacements in the ranges of  $\pm 5\text{mm}$  and  $\pm 5\text{ mrad}$ . We developed a low-cost 6D alignment sensor called “Praxial” to fulfill these requirements. This paper presents the principle of the sensor and the calibration bench. We will introduce the hardware, software, the absolute calibration procedure and conclude with the performances.

## 1. INTRODUCTION

The future LHC (Large Hadron Collider) experiment, ATLAS [1,2] is a particle detector which will be built at CERN-Geneva [3]. It has to confirm the theory called “standard model”. In that way, one of the goals is to give a proof of the Higgs particle existence. The theory predicts this particle should decay in 2  $Z^0$  particles each decaying in 2 leptons (e.g. muons or electrons). The muons will be identified with a trajectory calculation. The muon spectrometer [4] is 40 m long and 20 m wide cylinder made up of a set of  $\sim 600$  muons chambers. Figures 1 and 2 show a 3D view of ATLAS and the detail of a muon chamber respectively. In order to get enough accuracy in the pulse determination, the geometry of the muon spectrometer has to be known accurately. The alignment system determines the spatial position of the muon chambers with an accuracy of 20  $\mu\text{m}$  in a range of  $\pm 5\text{mm}$  for translations and 200  $\mu\text{rad}$  in a range of  $\pm 5\text{mrad}$  for rotations. It is assumed by several alignment systems (Projective, Reference, Praxial, Axial, In-plane etc), based on the RASNIK [5,6] sensor except for the Reference system. We are going to detail different elements in the following sections.

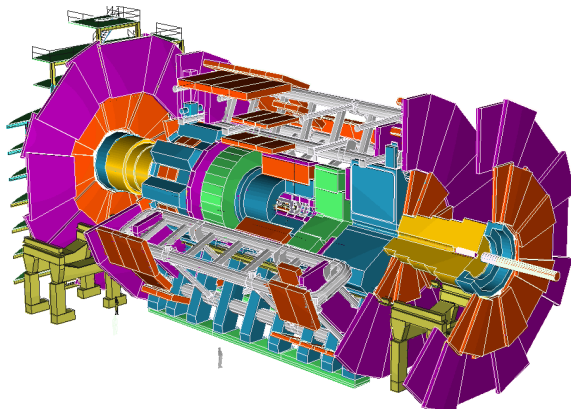

Figure 1: The Atlas detector.

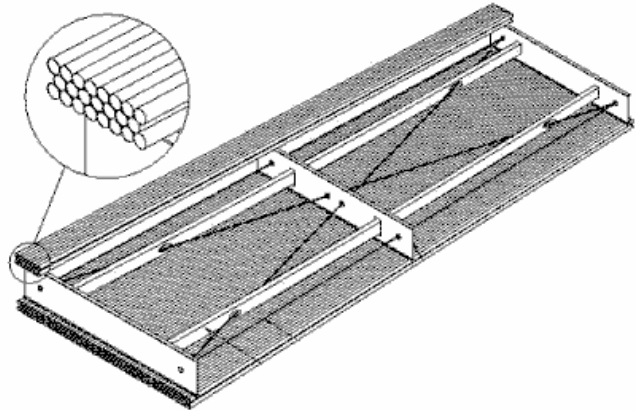

Figure 2: A muon chamber.

## 2. PRAXIAL ALIGNMENT.

The goal of the Praxial alignment is to measure the position of a muon chamber with respect to the neighboring ones in the 6 degrees of freedom with accuracies mentioned before. As the majority of the alignment systems, it uses the RASNIK sensor.

### 2.1. The RASNIK sensor.

This sensor has been developed by the NIKHEF institute from Amsterdam. RASNIK stands for Relative Alignment System from NIKhef. It is made up of three optical components (see fig. 3):

- A 2D coded mask, which is similar to a chess pattern with specific motives. This mask is lightened by infrared LEDs (780 nm).
- A video sensor such as CCD or CMOS.
- A lens to image the mask on the CCD.

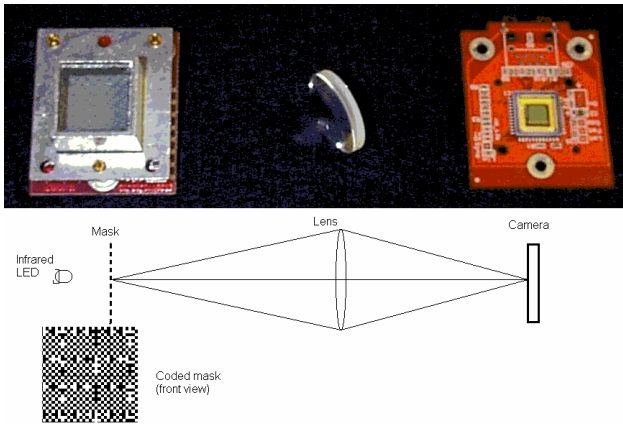

Figure 3: the RASNIK sensor.

The camera is read by a frame-grabber in a PC. The associated software, called ICARAS (Image Capture and Analysis for RASNIK), drives a multiplexer in order to operate the infrared LED and the camera. ICARAS also computes 4 parameters:

- The (X,Y) coordinates of the mask pointed by the center of the camera through the center of the lens. The accuracy on these parameters is around  $1\mu\text{m}$  in nominal conditions.
- The optical magnification, which is the ratio of the mask pattern and its value measured by the camera. The accuracy is around  $3 \cdot 10^{-5}$ .
- The relative angle between the mask rows and the pixels lines of the camera with an accuracy around  $200\mu\text{rad}$ .

## 2.2. The PRAXIAL sensor.

The Praxial sensor has been developed by the Saclay team. As fundamental, the Praxial sensor is the combination of two crossed Rasnik sensors. The optical components stand on two T-shape aluminum profiles. Both camera and lens of a sensor are attached to a profile; the associated mask stands on the other mechanical part (see fig. 4).

The Praxial sensor is a pair of mechanical structures each equipped with Rasnik element. In ATLAS configuration, a plate is mounted on a chamber, the other plate on the neighboring chamber. Due to particularities in the distribution of muon chambers in Atlas, the width between the two plates is in a range of 200 to 600 mm. The lens diameter is 10 mm and the typical focal lengths are 40-50 mm. The coded mask is  $20 \times 20\text{ mm}^2$  with a periodicity of  $170\mu\text{m}$  (size of black or white square) and the camera area is  $4.5 \times 3.5\text{ mm}^2$  with  $12\mu\text{m}$  pixels. In these configurations, the magnification is in a range of  $1/7.3$  to  $1/1.3$ .

To ensure a good positioning of the support on the chambers, the mechanical structure stands on a 6 spheres interface (plan, line, point) in order to lock the 6 degrees of freedom. They are called "positioning spheres".

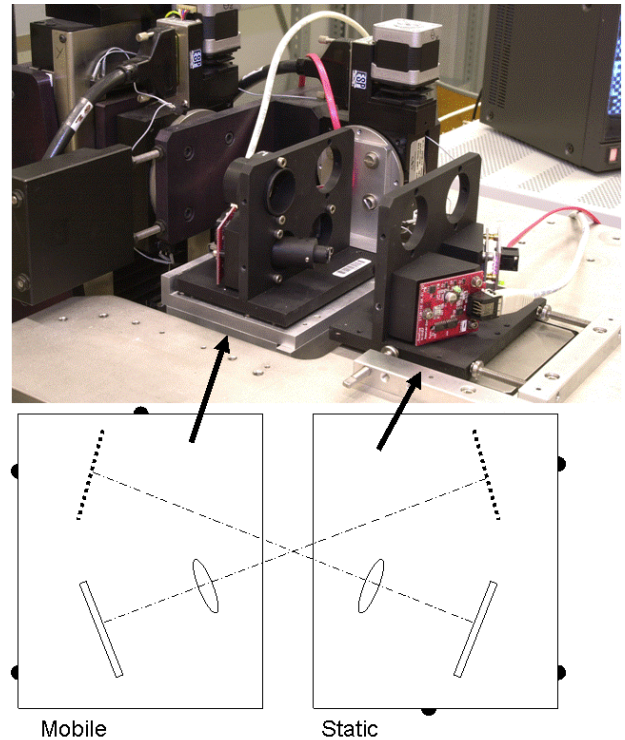

Figure 4: picture and top view drawing of the praxial sensor (top and bottom respectively).

As this sensor uses two Rasnik systems, it gives two sets of four coordinates. The goal of the calibration process is to calculate the six parameters: three translations and three rotations from the eight coordinates.

## 3. CALIBRATION OF PRAXIAL

In the muon spectrometer, a set of 1250 Praxial sensors will run simultaneously. To reach the accuracy level on the sensors, we have developed a semi-automatic calibration bench called "Caliprax" [7].

As we already have written, the Praxial sensor provides 8 coordinates to determine the 6 parameters of a movement. The Calibration bench scans all the working space of the sensor to determine its transfer matrix. For this, one half of the sensor stands on a static part, while the second part is mounted on a mobile support. As the transfert matrix is correlated with the geometry of the sensor, it is unique for a Praxial sensor.

### 3.1. Hardware.

The hardware of the calibration bench can be detailed according to the function of elements:

- *The mechanical structure* is made in stainless-steel and has precise machined parts. It supports the static element of the Praxial sensor for each Atlas configuration (9 positions). It also supports the probes interface.

- *The mobile actuator* is a set of six motorized tables assembled in order to move the mobile support in 6 degrees of freedom (see fig. 5). The resolution of displacements is  $1\mu\text{m}$  for translations and  $0.0005^\circ$  ( $\sim 1\ \mu\text{rad}$ ) for rotations. All motorized tables have “ghost” moves when you ask for a displacement. In order to know accurately the spatial movement of the mobile part, we implement mechanical probes. The tables are PC commanded by a specific driver through RS232 port.
- *The mobile support* is a precise machined interface between the motorized tables, the half-Praxial sensor and the mechanical probes (see fig. 6). This piece is screwed on the last moving stage. All the areas in contact with Praxial positioning spheres or the extremities of mechanical probes are hardened and rectified steel inserts. The tolerance on the geometry of the mobile support is below  $10\ \mu\text{m}$ .
- *The probes* (see fig. 7). Their function is to compute the 6D movement of the mobile part. The acquisition is assumed by a PC through RS485 device. The probes we used are optical linear encoder, with  $1\ \mu\text{m}$  relative accuracy in the range of 12 mm. To avoid the erosion of the parts in contact, we replace them by sapphire balls. The probes are maintained in a precisely known mechanical interface (CMM measurement).
- *A concrete block* supports both motorized tables and mechanical structure. It ensures the long term stability required to calibrate the 1250 Praxial pairs.
- An accurate mechanical support, called “*Zeroprax*” is used as reference position for a Praxial sensor. It is a precise machined template where the positions of the two parts of Praxial sensor are known with less than  $10\ \mu\text{m}$  of uncertainty.
- *A bar-code reader* allows a human free identification of the Praxial sensors.
- *Pt100 probes* are set to locally measure the temperature on the bench.

After the description of the bench hardware, we are now going to describe the software.

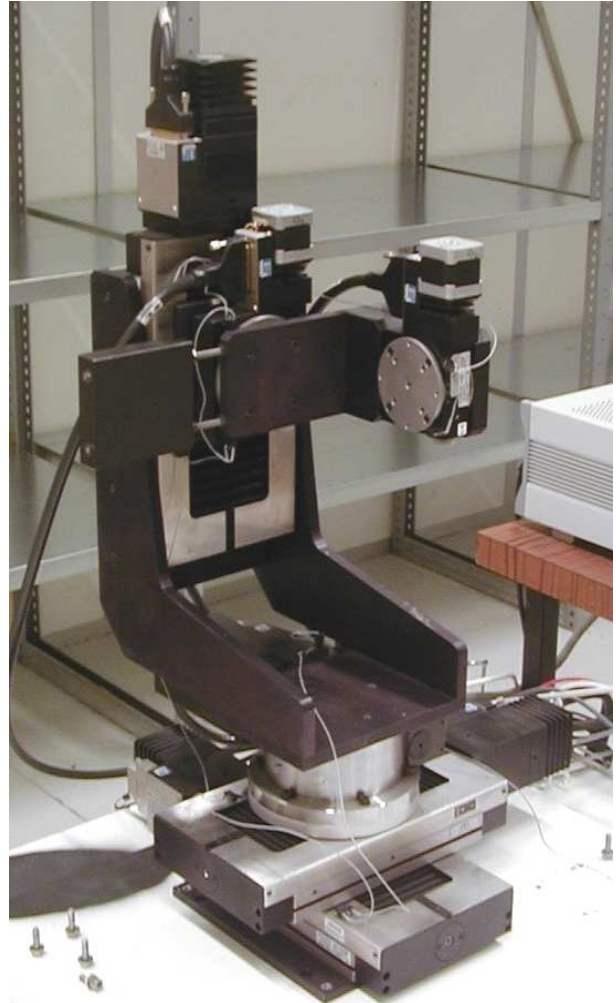

Figure 5: the 6 axis motorized tables.

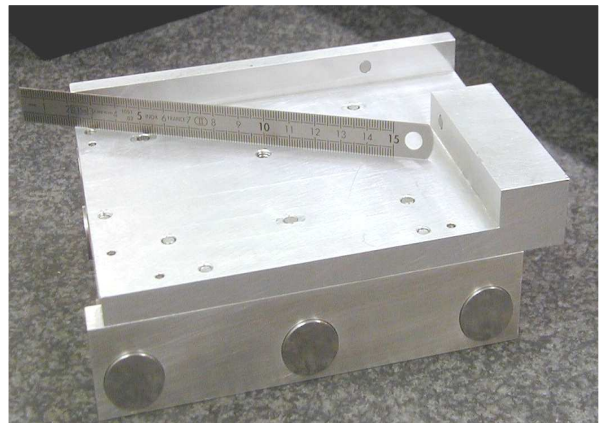

Figure 6: The mobile support

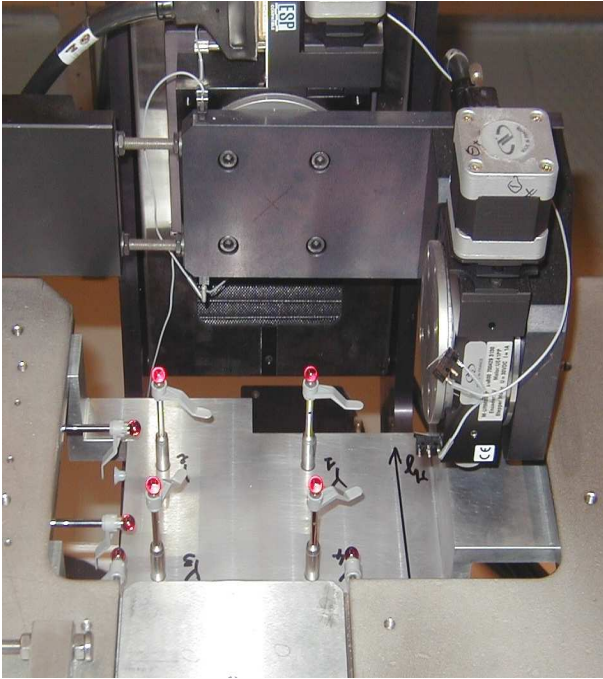

Figure 7: the mechanical probes with sapphire touching balls.

### 3.2. Software

The programs we developed are in C++ language under Windows environment [8]. The choice of PC architecture was done with cost motivations. On the computer, three programs are running simultaneously:

- A set-up software to configure the tables driver, the temperature probes acquisition card, the RS485 device (displacement probes). In this software are also declared all geometrical parameters for movement reconstruction,
- Icaras, the software which lights on the LED, captures the frame of CCD and analyses the picture to compute the four parameters of a Rasnik sensor,
- The main program to perform the calibration process.

### 3.3. Calibration process

The Praxial sensor is identified with its bar-code. The first stage of the calibration consists to save the eight Rasnik data at a known position. To achieve this, the two parts of a Praxial sensor are manually set in the Zeroprax support (see fig. 8). This particular position is used as reference for the following stages.

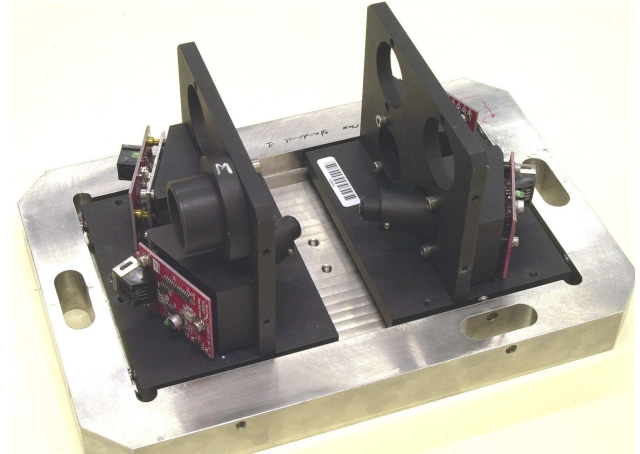

Figure 8: The Zeroprax support.

After this, the praxial sensor is set on the Caliprax (see fig. 9) to perform the automatic relative calibration.

- An automatic procedure sets the mobile support in order to have the same measurements than at reference (Zeroprax) position on both Rasnik sensors. At this point, the tables are reset. We call this “zero positioning”.
- The program scans the working space by setting the mobile part at each extremity of each axis in the range of +/-5 mm and +/-5 mrad around the zero position. Considering the 6 degrees of freedom, this stage is a set of 64 positions. At each position, the real movement is computed from the mechanical probes and recorded with the Rasnik data.
- The program computes the transfer matrix. This matrix is 6\*8 numbers, determined by linear calculation. (A geometric method can also be applied [9].) In (1), M is the absolute position of the mobile part (column), T is the transfer matrix, R is a row vector of the eight Rasnik parameters, d is a column vector which quantify the error between zero and reference positions. M and d are unknown i.e. 54 parameters.

$$M=T*R+d \quad (1)$$

At least 9 movements are strictly necessary to constrain the system. Simulation showed us that few tens of movements are necessary to get enough accuracy

- A set of 50 random positions are driven. At each position, the program applies the transfer matrix to Icaras data and compares the results to the movement characteristics issued from displacement probes. The distribution of errors is calculated and used as rejection criteria when the rms is out of range (20 μm or 200 μrad).
- The transfer matrix and data from the reference position are stored in a database.

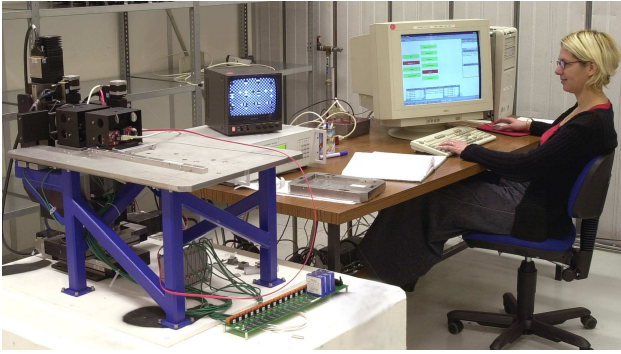

Figure 9: global view of the Caliprax.

Considering a relative calibration made on the Caliprax in addition with a reference position obtained with Zeroprax, the Praxial sensors are calibrated in absolute way.

#### 4. PERFORMANCES

The most important thing is to have a stable bench within a calibration period (45 minutes). We checked the stability during four hours periods. Figure 10 shows the stability graphics with regards to translation (on left) and rotations (on right). The stability is better than  $1 \mu\text{m}$  for translations and  $10 \mu\text{rad}$  for rotations. The graphics shows small oscillations due to the air-cooling system. Their amplitudes are below  $0.5 \mu\text{m}$  and  $3 \mu\text{rad}$ , so they have been neglected.

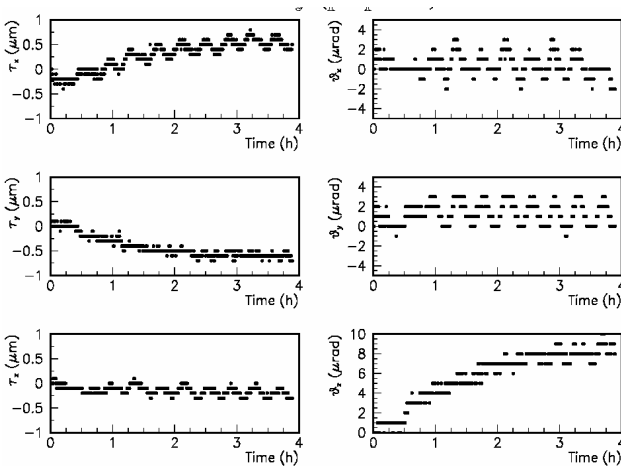

Figure 10: stability of the bench for four hours on X, Y, Z translations and rotations (left and right respectively).

To test the accuracy of the calibration process, we drive thousand random positions with a calibrated Praxial sensor. The accuracies are below  $10 \mu\text{m}$  on translations and below  $100 \mu\text{rad}$  on rotations for displacements in the range of  $\pm 5 \text{ mm}$  and  $\pm 5 \text{ mrad}$ . If we consider the results of 700 calibrated sensors (see fig. 11), the performances are the same for the configuration in which the two parts of the sensor are closed to each other. They slightly deteriorate as the distance increases. For the most distant one (370 mm), the accuracy is only  $60 \mu\text{m}$  for the translation.

We also check the stability by calibrating successively the same Praxial sensor. We found the stability is below 3%. If we repeat this test at different times, the reproducibility is below 6%.

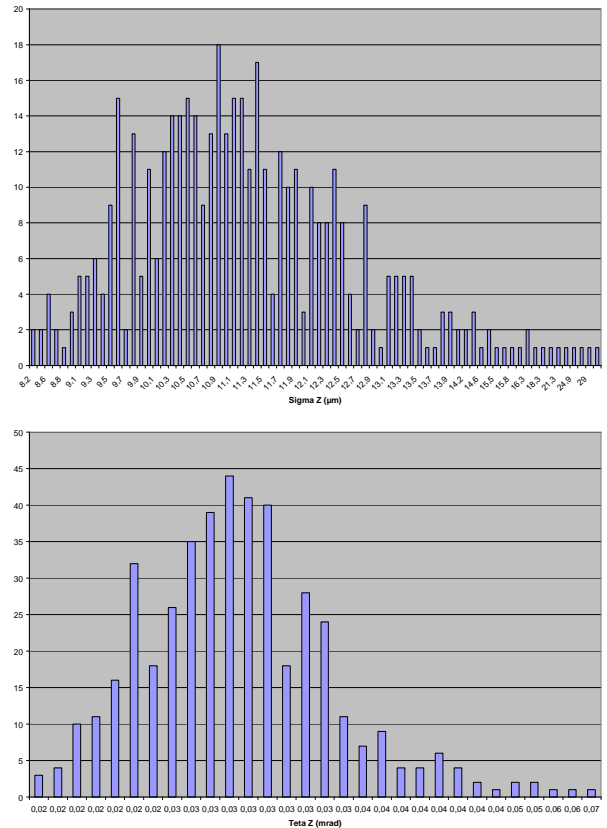

Figure 11: results of calibrated sensor Z (optical axis) accuracy on random positions. The values are in  $\mu\text{m}$  for translation (top) and in  $\mu\text{rad}$  for rotations (bottom).

#### 5. CONCLUSION.

This paper describes an absolute alignment sensor, efficient on the six degrees of freedom. We detailed the hardware and the principle of the calibration and gave the final resolution. The sensors ran in the H8 experiments (scale 1 test of muons chambers at CERN) in 2002, 2003 and 2004.

Among other systems, Atlas detector will be equipped with more than thousand Praxial sensors to achieve the knowledge of the muon chambers positions with a precision of  $20 \mu\text{m}$  and  $200 \mu\text{rad}$  in translations and rotations respectively.

The installation of the sensors is in progress and we already run some sensors. This allows us to measure deformations on the coils structure with night and days effects.

BIBLIOGRAPHY:

- [1]: *ATLAS technical Proposal*, CERN/LHCC/94-43, 15 December 1994
- [2]: <http://www.atlas.ch>
- [3]: <http://www.cern.ch>
- [4]: *ATLAS Muon Spectrometer Technical Design Report*, CERN/LHCC/97-22, 31 may 1997
- [5]: H Groenstege et al., *The Rasnik*, ATLAS Muon note 63 (1994)
- [6]: H Van Der Graaf et al., *Rasnik, an alignment system for the ATLAS MDT barrel muon chambers. Technical description*. Publication of NIKHEF institute ET38110, April 2000.
- [7]: V. Gautard et al. *Calibrations of two alignment sensors used in the ATLAS barrel spectrometer*, IEEE 2004 Nuclear Science Symposium and Medical Imaging Conference, Rome (Italy) October 16<sup>th</sup> 22<sup>nd</sup>, 2004.
- [8]: V. GAUTARD, O. Cloué, *PC based control of a calibration bench for the ATLAS experiment*, Frascati (Italy) 2002.
- [9]: V. Gautard, J.-P. Schuller, *resolution d'un système physique à 26 paramètres*, CANUM-2002, Anglet (France), 27 - 31 may 2002, Eds. SMAI, Proc. (2002) 301. In French.