

D. Yvon^{1,*}, J. Panh², J. Landé³, P.
Eng⁴, N. Briand⁴, G. Guyot⁴, R.
Pons³, J. Narbonne³, D. Brienza⁵, P.
DeBernardis⁵, S. Masi⁵

My Bolometer is running a Fever, Or why very low noise performances requires global design of the apparatus.

the date of receipt and acceptance should be inserted later

Keywords Low temperature detectors

Abstract Thanks to intensive developments, bolometer sensitivity has improved by orders of magnitudes. Measurements now involve energies that are incredibly small, when compared to everyday hardware. Thus, when used in an industrial environment, taking advantage of their performances requires much care to prevent noise from overwhelming the signal. In this paper, we show, taking the Planck Instrument as an example, that proper design of subsystems is mandatory, but no longer sufficient to achieve required performances. A global design of the apparatus for low noise is needed, and we explain how to do it.

PACS numbers: 07.57.Ty, 07.57.c, 95.55.Fw, 07.20, 29.40

1 Introduction

Bolometers are now widely use in the scientific community for many purposes¹. Their main advantage is to be sensitive to a very wide range of phenomena: bolometers degrade the energy of the signal, and measure the corresponding temperature rise, providing access to phenomena hard to observe with other methods. The second main advantage is their low noise. Because bolometers work at temperature close to 0K, minute energy releases can be quantified precisely. With time, sub-millimeter sky observations have dramatically improved. Fig 1 shows the full sky maps of the Cosmic Microwave Background, as observed by experiments since 1990. Indeed, required detector noise to

¹ DSM/DAPNIA, CEA/Saclay, Bat 141, F-91191 Gif-sur-Yvette Cedex, France,

² CNES Toulouse, 18 Av. Edouard Belin, 31000 Toulouse

³ CESR, 9 avenue du Colonel Roche, BP 44346, 31028 Toulouse Cedex 4,

⁴ IAS, Centre Universitaire dOrsay, Bât 120-121, 91405 Orsay Cedex,

⁵ Dipartimento di Fisica, Università di Roma La Sapienza, 00185Rome, Italy

* Corresponding author, E-mail: yvon@hep.saclay.cea.fr

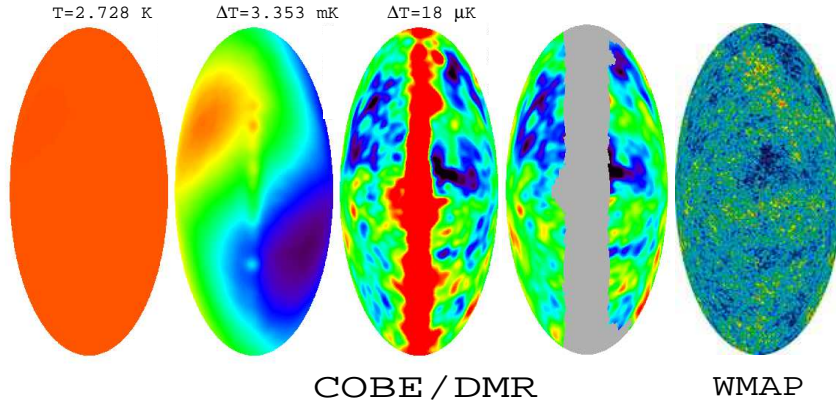

Fig. 1 Full sky Cosmic Microwave Background observations as observed with time, from Penzias and Wilson to WMAP 1 year observations. From one step to the next, the main component as been subtracted. From left to right, monopole, Dipole, Galaxy and CMB anisotropies as observed by COBE/DMR and WMAP.

observe a pixel of these sky maps decreased by 5 order of magnitude between COBE² and the future Planck³ satellite. Planck bolometers have noise performances of the order of $10^{-17} W \cdot Hz^{1/2}$. Such noise performance has a cost. Cryogenics is clearly demanding and expensive, but what is not obvious is the instrument design required to achieve such low noise performance. Such a bolometer is sensitive to $10^{-16} W$, whether it comes from the sky, or from a transient of a nearby power supply. Furthermore, though bolometer designers use state of the art thermometers to sense temperature variations, the noise level on the electrical signal at the readout input is very small, $\sim 1 fA / Hz^{1/2}$ and few $nV / Hz^{1/2}$ on the typical Planck bolometer of few $M\Omega$.

This paper presents design, implementations, and tests conducted to achieve good noise performance on the Planck/HFI instrument. The methods and technical designs are of wider interest. We believe these methods can be used/upgraded to most applications using high impedance bolometers.

Below, we first present a short review of the meaning of noise, noise spectrum, as well as orders of magnitudes relevant to the Planck High Frequency Instrument (Planck/HFI) apparatus. Then we present a focused view of the Planck/HFI apparatus from the readout point of view and show that uninvited annoying guests "non fundamental noises", namely microphonics, ElectroMagnetic Interferences, make the designer life difficult. We expose the main pick-up mechanisms relevant to our apparatus and the cures implemented first at subsystem then at satellite levels.

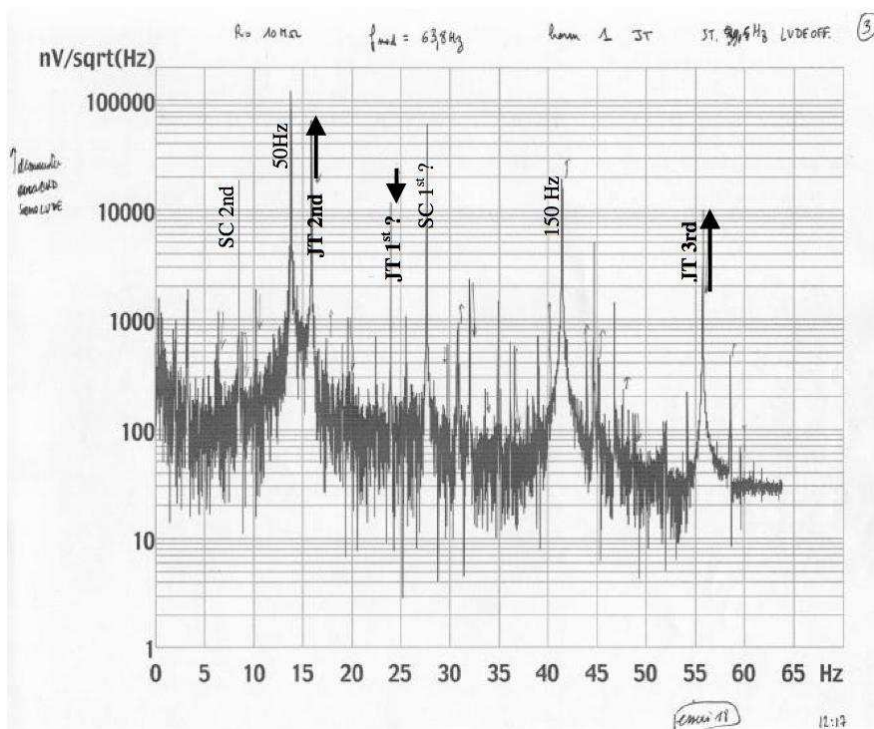

Fig. 2 Power spectrum observed, using a locking amplifier, in the *first* Planck/HFI hardware consistency check, back in the year 2000. Nominal Planck/HFI noise is expected less than $10 \text{ nV}/\text{Hz}^{1/2}$. Please notice the log scale.

2 Noise, what does it mean?

We aim at measuring a small scientific signal, a power or an energy, when using a bolometer. A single measurement is not precise enough, thus we run many imprecise "Noisy" measurements. In the best case, we observe a Gaussian distribution of measured values. The mean of the distribution converges to the true signal value and the rms is what we name "noise value" σ_{Noise} .

We now assume that we are sampling the signal voltage at the output of a bolometer. The resulting *timeline* $Mes(t_i)$, can then be analysed in the Fourier space, to compute the *noise spectral density* (so called noise spectrum) that quantifies the contribution of each frequency to the timeline *variance*. Fig 2 shows a very "structured" (bad) spectrum, from real life, where noise lines have been associated with known perturbation sources. Why is it so? Though we have an excellent detector (and optic, cryogenic, etc.....), the signal level at the output of a bolometer is very very, small. This signal comes along with a long list of fundamental noise sources. Among them we can list optical noise, detector thermodynamic noise, thermometer Johnson

noise, preamplifier readout noise. The designer tries to insure that the optical noise (intrinsic to the signal) dominates all other noise sources. Planck bolometers will be run at 0.1K, with impedance of a few $M\Omega$. We measured bolometer thermal noises of $\sim 10^{-17}W/Hz^{1/2}$, thermometer Johnson noise of few $nV/Hz^{1/2}$ or $\sim fA/Hz^{1/2}$ and we know that optimized JFET proved noise level of $\sim nV/Hz^{1/2}$ and $0.1 fA/Hz^{1/2}$. Is everything OK? Not yet, we forgot the uninvited guest, parasitics.

$$\sigma_{Total}^2 = e_{nth}^2 + e_{nJ}^2 + e_{nel}^2 + (R_b i_{nel})^2 + i_b^2 (\Delta R_{bpar})^2 + (R_b i_{par})^2 \quad (1)$$

where σ_{Total} is the total noise, e_{nth} , e_{nJ} , e_{nel} , $R_b i_{nel}$ are the fundamental, thermodynamic, Johnson, and readout (voltage and current) noise contributions, and the two contributions from parasitics, that arise through two different processes. If any kind of energy (IR radiation from thermal instability in the optics or a transient from a nearby power supply...) dissipate in the bolometer absorber or thermometer, the induced temperature change is sensed by the thermometer and produces a voltage noise, $i_b \Delta R_{bpar}$. Then any pick-up current i_{par} on the high impedance readout line is detected as a voltage $R_{th} i_{par}$.

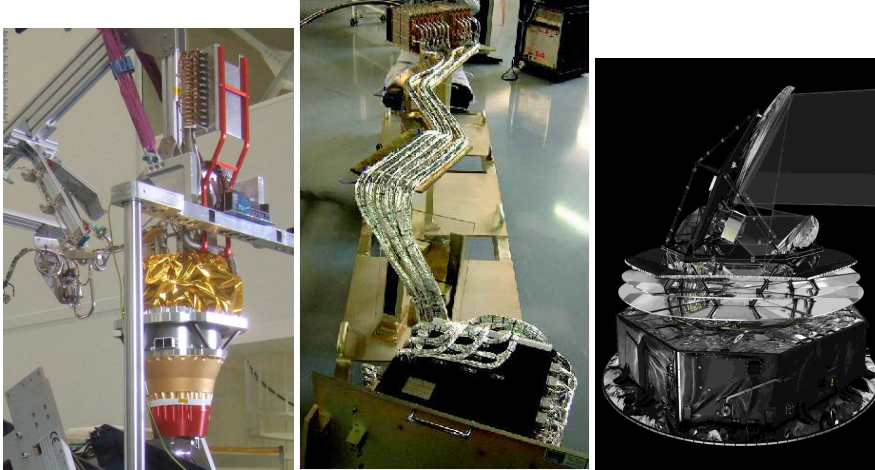

Fig. 3 Some of the Planck satellite and the HFI instrument.
left a): Planck/HFI focal plane housed in the 4K cryostat, waiting for integration.
center b): Part of Planck/HFI readout electronics and harness. In the foreground is the post-amplification and sampling electronics. In the background is the preamplifier unit. Please notice the length of the harness . **right c):** Artist view of the Planck satellite.

3 A focused view on the Planck apparatus

An introduction to the Planck Instruments can be found in Tauber et al⁴. From the point of view of readout noise, the construction of the Planck/HFI

instrument was a daunting task. Fig 3 helps to understand why. The Planck/HFI focal plane is embedded in a 4K shield/Faraday Cage where the bolometers are cooled at 0.1K (Fig 3a). The focal plane is placed below the main mirror (Fig 3c). The bolometer signal (noise level 50 nV rms, 10 fA rms, typically) is then pre-amplified by the JFET Box, placed *1.5 meter away* behind the main mirror and a radiation shield (Fig 3b) so as to prevent the JFET-Box black body radiation from disturbing CMB measurements. The JFET follower lower the signal impedance to $\sim 300\Omega$, but doesn't amplify it to prevent gain instability. Then the signal (noise level 50 nV), travels through the 3 V-groove radiation shields over *2.5 meters* to the satellite service module and the PreAmplifier Unit (PAU, Fig 3b), where it is amplified by a factor 1000. Finally, after a journey of 5 more meters around the service module, the signal ($\sim 50\mu V$ rms) is post-amplified and sampled in the REUnit, wisely placed 10 cm away from the cryogenics pumping system, radiating magnetic field of the order of 1T at 80 Hz. Common sense recommends minimizing the cable length carrying the low level signal. Other constraints on the apparatus (science, thermal load, satellite balance) made it impossible. Thus we expect big concerns due to parasitics in the readout.

The *first* Planck/HFI hardware consistency check happened in year 2000. Though subsystems did work separately, when mounted together (without much care) electromagnetic pick-up was so strong that with a cryostat running at 130 mK, bolometer temperatures were measured at 2K. Figure 2 shows the noise spectrum after few weeks work. Is it serious doctor? I am afraid the answer is yes.

4 Contamination mechanisms and cures

In this context, the specialized vocabulary for *noise sources* is *threats*, that for *pick-up* is *contamination* and an apparatus suffering from contamination is said to be *susceptible*. With $M\Omega$ impedance detectors, contamination arises through current injections on readout lines (Figure 5a). Below are the main process and their cure.

4.1 Microphony

This is what happen when a mechanical wave shaking your apparatus is transformed in a spurious detected signal. Planck bolometers are known to be robust in regard of microphony. Microphonic contamination in the readout harness happens through 3 processes. Capacitive coupling, cut flux in a magnetic field and tribo-electricity. Shielding readout wires, stiffening the harness *and* wires inside the electronic board minimizes the two first effects. Dealing with tribo-electricity requires more work. Shield braid rubbing on dielectric produces charges that stay at the dielectric surface. Latter mechanical stress induces partial release of these charges to the braid, and induces through capacitive coupling current on readout lines. To prevent this, cable makers produce "low noise" cables, using carbon based semi-conductive coating of dielectric surfaces, that prevent charge from building up, draining them to

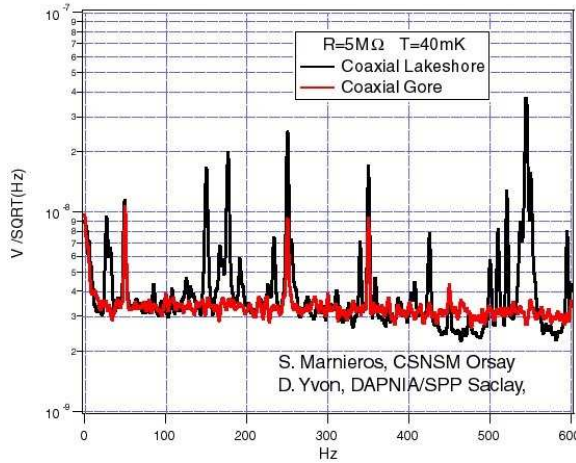

Fig. 4 Noise spectrum measured on a $5M\Omega$ resistor placed a 40 mK temperature. The black spectrum was measured with an off the shell coaxial cable running between the bolometer and the preamplifier. Replacing only this cable by a tailored designed low noise/temperature coaxial cable, we obtained the above red noise spectrum. Microphonic noise vanished.

the braid. Adaptation of these technologies for low temperature operation proved to be very efficient, as shown on figure 4b) in the context of the Edelweiss0 experiment. Since then, in the context of Planck and Olimpo⁵ balloon project, we developed tailored designed cable technologies, with no detectable tribo-electricity effect.

4.2 Conduction Mode Electromagnetic Interferences (EMI)

Planck payload power consumption is a few kW. Power Supplies are regulated using DC/DC converters for efficiency, and engines and computers are running on board. All these apparatus are known to be very "noisy". Specifications state that your instrument should not display any performance degradation with 1A current, (limited to 1 volt), on powerlines. Due to capacitive coupling or poor hardware design, the mechanical structure and shields are loaded with currents, and because of cryogeny, these are resistive. If we use an unipolar readout such as sketched in figure 5b), using the mechanical ground as the return path for the biasing current, the readout detects the current loading the mechanical ground. If we do use a return line to the preamplifier board (better option), the ground currents induce voltage changes in the detector vicinity and through capacitive coupling, load the readout line.

Differential readout is known to be a better option, getting rid of the previous mechanism at least in theory. In practice, such a design require a very careful symmetry all along the readout chain. But cable makers explain they cannot avoid 5 % asymmetry between central conductor length (i.e. capacity to shield), when producing shielding twisted pair cable. Thus residual con-

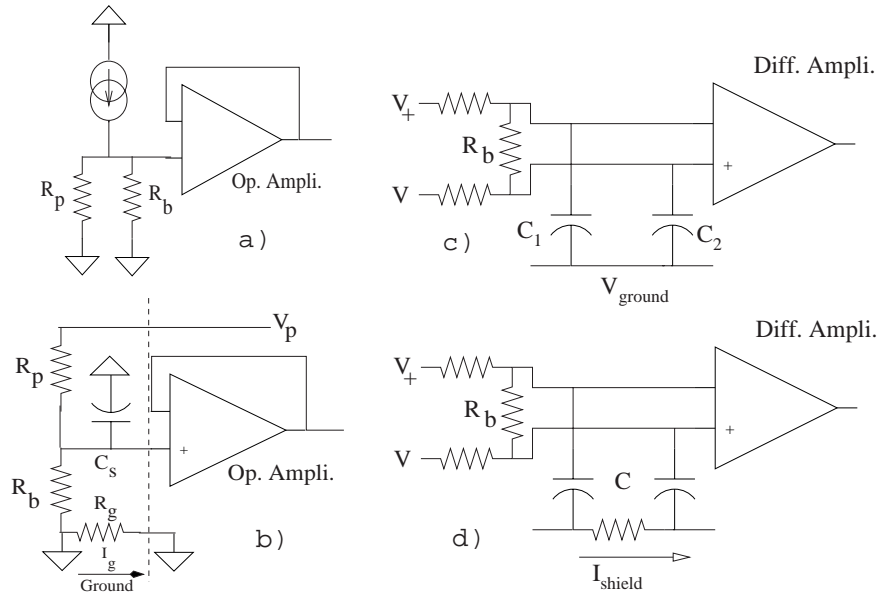

Fig. 5 Contamination processes in high impedance readout electronics. **a)** In these conditions, contamination occurs through current injection on readout. **b)** Contamination processes when using unipolar electronics. **c and d)** Contamination processes when using differential readout electronics.

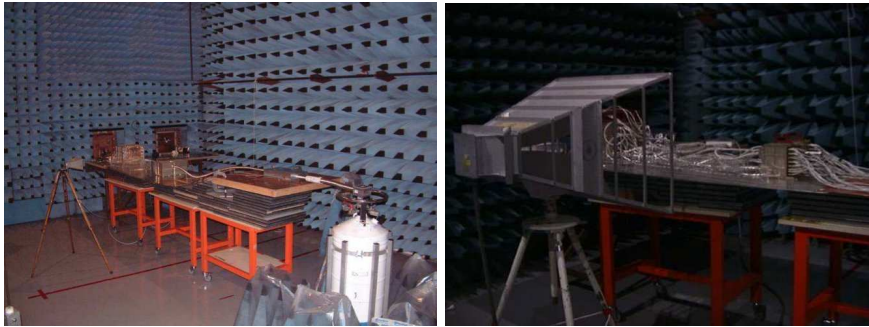

Fig. 6 Test Bench used to debug and validate the HFI readout electronic behavior in conduction mode (**right**), and radiative mode (**left**) ElectroMagnetic Interferences.

tamination occurs through the process in figure 5c). In addition, if the two readout lines were identical in shape, if the ground is loaded and resistive, contamination happen through process in figure 5d).

After careful design of all the subsystems we went then through an extensive test campaign on the mock model of HFI readout (figure 6). After some (a lot of) work, we concluded that the whole system passed all the tests, if we replace the harness between bolometer and PAU by termina-

tors. With bolometers connected we quantified that a 10 nA current load on the mechanical ground surrounding the bolometer induced unacceptable contamination.

5 Global instrument design for low readout noise

All the subsystem match specifications, and have been optimized for low noise. What more can we do? Back to the beginning:

1-Identify all threats within the satellite. Power supply, Engines, Antenna, noisy electronic boards (Other instruments). Identify susceptible apparatus (high impedance low level signal readout).

But now

2-Minimize by design, common mode currents in satellite ground and instrument shields around susceptible areas. Issue recommendations for satellite/apparatus design. And

3-Interpose in instrument/Satellite design, i.e. talk to designers, related to mechanics, cryogenics (we requested insulators in mechanical structure), electronics, harness, and other instruments, Spacecraft industry, trying to move threats far from susceptible area. *Act diplomatically*. Points 2 and 3 involved a lot of effort: given the complexity of the satellite payload, to understand ground current, a simulation is mandatory. This is what we wrote and is shown at figure 7. With such a software we are able to understand the contamination paths within the payload mechanics, and check the efficiency of proposed changes.

In the end more than 20 electrical insulations were introduced in the mechanical structure and gas handling system, under strict constraints on thermal conduction or gas pressure handling behavior. Figure 8 shows a few "details" involved in real life. Carbon fiber tubes end with teflon insulators inserts. 4K cooler and 20 K cooler cold points are insulated from the "reference plates using 4 Sapphire cylinders each, that ensure thermal conduction. Gas handling tubing connects to the 4K cryostat using Sella ceramic tubing.

This work done, the Planck/HFI instrument has been calibrated in Saturne Cryogenic facility. That was a opportunity to test the noise performances in an industrial environment. Figure 9 display nominal noise, from 10^{-2} Hz to 80 Hz. This makes us confident that we understand Conduction Mode Electromagnetic Interferences in the Planck apparatus.

6 Radiated Mode Contamination

To prevent electromagnetic waves induced currents in readout, *careful* shielding must be implemented. Radiated E-fields convert into current in shields and induce *conduction* mode EMI, on which we worked a lot. Clamping shields to the closest mechanical ground prevents currents from propagating far in the apparatus. Magnetic fields decay quickly with distance, but when a major threat happen to be close to a susceptible device, we choose to shield the threat. Extensive tests (Figure 6) allowed us to debug and check behavior

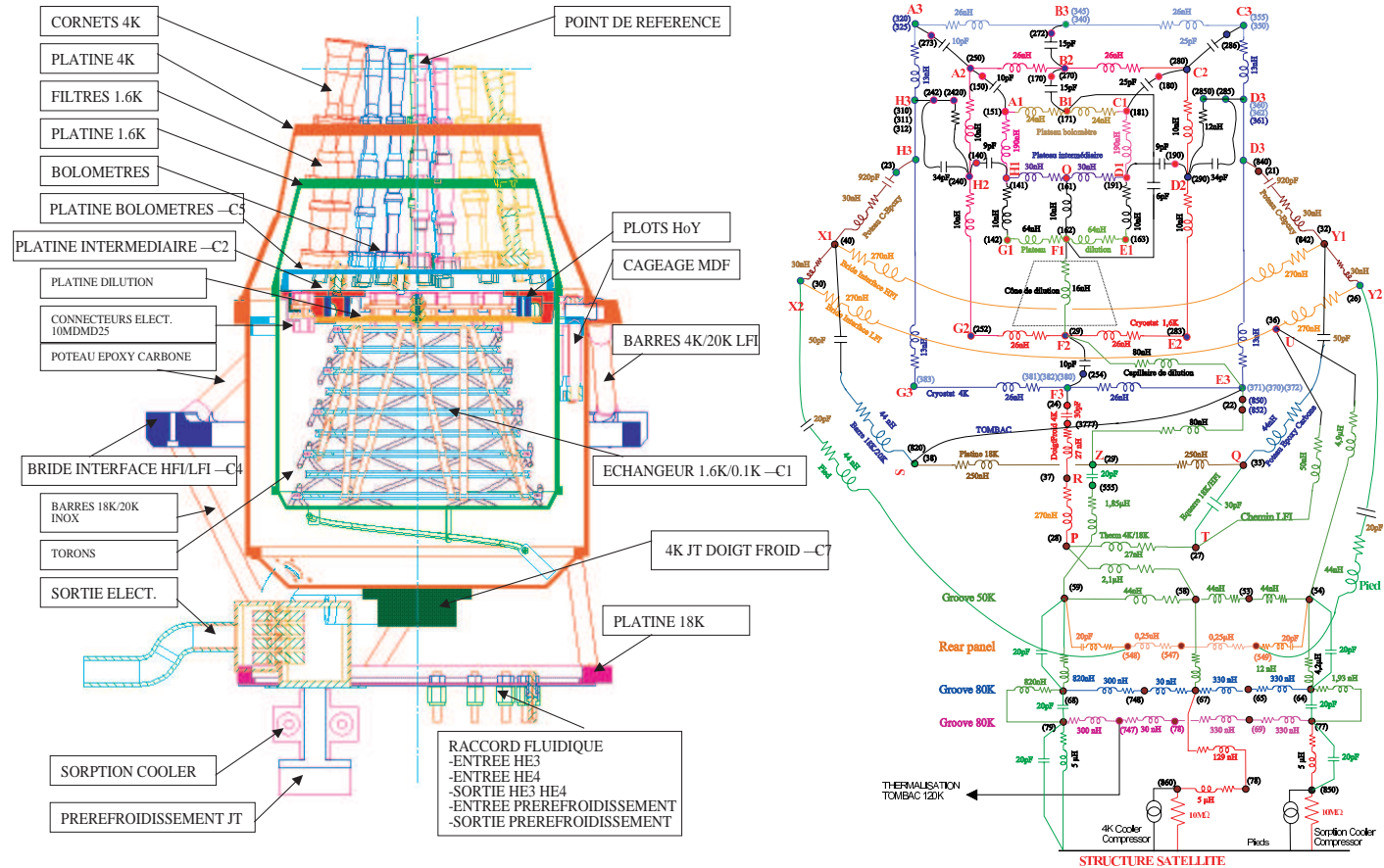

Fig. 7 **left** mechanical drawing of the Planck/HFI 4 K cryostat, dilution unit and focal plane. **right**. Corresponding electrocinetic model used to understand conducted mode contamination paths in the Planck/HFI apparatus. In this model the emphasis has been placed on mechanisms taking place inside the 4 K cryostat. Five of these models were developed to understand Planck Readout.

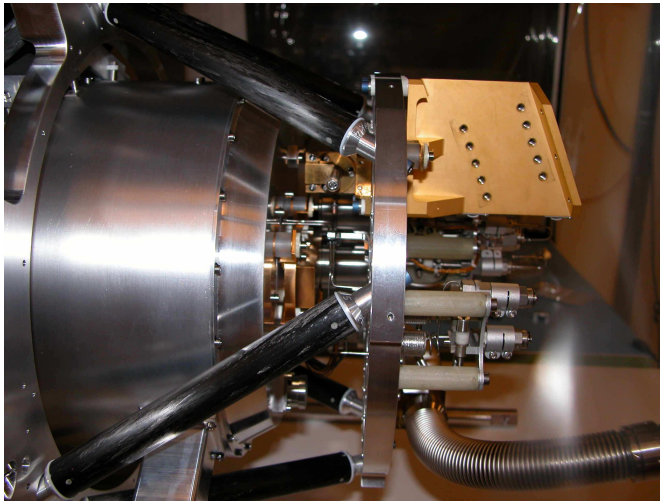

Fig. 8 View of the Planck flight model focal plane unit, focusing on the 4K and 18K coolers cold point connections to the 4K cryostat.

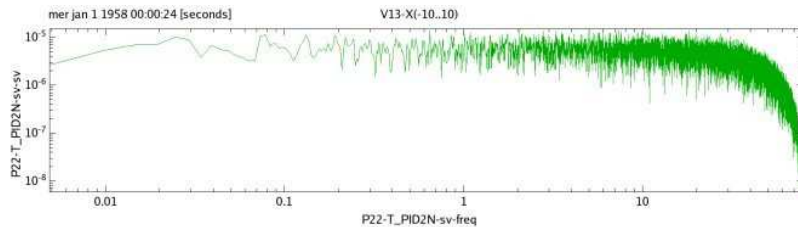

Fig. 9 Noise spectrum measured on the Planck/HFI calibration test bench on a $10M\Omega$ thermometer at 100 mK. The Noise spectrum display no contamination line left, and is dominated by Johnson noise from 10^{-2} Hz to 80 Hz. *We are happy.*

from 30 Hz to 300 MHz and more, with an E-field up to 10V/m and B-field up to 1 Tesla.

7 Conclusions

In this paper, we presented some of the Planck/HFI hardware, and explain the necessary steps to achieve low noise readout of state of the art bolometers in an industrial environment. We showed that proper design of subsystems (harness, JFET Box, PAU, REU, etc...) is mandatory and this was conducted carefully. But that was no longer sufficient to achieve required performance. Conducted Electromagnetic Interferences turned out to be a major problem, and the understanding and control of currents circulation in the mechanical structure appeared to be mandatory. Consequences on mechanical/thermal

design are important, and the sooner Electro-Magnetic Compatibility is taken into account in the design the better. In the end, it works.

Acknowledgements We want to thank C. Dumesnil, A. Arondel and M. Charra (IAS/Orsay), for listening constructively to our suggestions, during the Planck/HFI "EMC Design", and the IAS and CESR teams for their support in preparing and running the numerous tests bench needed for debugging. Finally, I want to thank J. Rich and the Referees for carefully reading the proofs.

References

1. Proceedings of the LTD12 conference, *J. of low temp. Phys.* this issue.
2. G. Smoot et al., *Ap. J.*, **360**, 685, (1990)
3. J.M. Lamarre et al., *New Astronomy Reviews*, **47**, 1017, (2003).
4. J. Tauber et al., *Proceeding of IAU Symposium*, **204**, 493, (2001).
<http://sci.esa.int/science-e/www/area/index.cfm?fareaid=17>
5. F. Nati et al., *New Astronomy Reviews*, **51**, 385, (2007).