

Applications of superconductors in electrical engineering

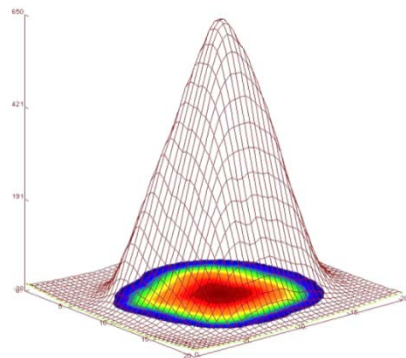

Pr B. Douine & Dr K. Berger
GREEN - Lorraine University



Outline

- About the GREEN
- Motor's realizations
 - Flux concentration motor
 - Synchronous motor
 - Axial motor with magnetic coupling
 - Flux barrier motor
- Bulk magnetization activities
 - Field cooling process with MgB₂ samples
 - Pulsed Field Magnetization with REBCO

Research Team

- Permanent Members

- Pr J. Lévêque (team leader)
- Pr B. Douine
- Pr A. Rezzoug (emeritus)
- Dr K. Berger
- Dr G. Didier
- Dr M. Hinaje
- Dr S. Mezani
- Dr T. Lubin

- PhD Students

- R. Alhasan
 - C.H. Bonnard
 - B. Dolisy
 - B. Gony
 - R. Linares
- ☹
 - 1/2 permanent technician
 - no permanent engineer

Academic collaborations

- KIT (M. Noe, F. Grilli)
- University of Applied Science Mannheim (S. Elschner)
- Saarland University (M.R. Koblichka)
- Polytechnique Montréal, Quebec (F. Sirois)
- Center for Superconductivity, University of Houston, (P. Masson)
- University of Liège (P. Vanderbemden)
- University of Alger and Khémis-Miliana (E.H. Ailam)
- National Autonomous University of Mexico (F. Trillaud)
- French labs:
 - CRETA-CNRS (X. Chaud) and Grenoble Electrical Engineering Laboratory (P. Tixador),
 - Institut Jean Lamour in Nancy (S. Mangin and T. Hauet),
 - CRISMAT laboratory (J. Noudem and P. Bernstein)...

Industrial collaborations

- Jeumont Electric: Project REIMS (Inductor of a machine)
- Converteam (now GE): ULCOMAP for ULtra-COmpact MArine Propulsion
- DCNS - French industrial group specialized in naval defense and energy
- EADS and Airbus Group (Design of superconducting machines for Aircrafts)
- Hispano-Suiza and Safran Group
- DGA for General Directorate for Armament (Design and realization of superconducting machines)

Research topics and expertise

- Characterization of materials
- Modeling (FEM and analytical)
- **Superconducting motors**
- Magnetic coupling transmission
- Superconducting fault current limiter and electrical network
- ... other applications

Motors design and, their realization

- 5 motor's projects since 2006
- 4 motor's realizations since 2006
- 2 ANR grants (French National Research Agency)
- Most of our industrial collaborations

The original idea of the GREEN

- Superconducting magnetic field concentration motor

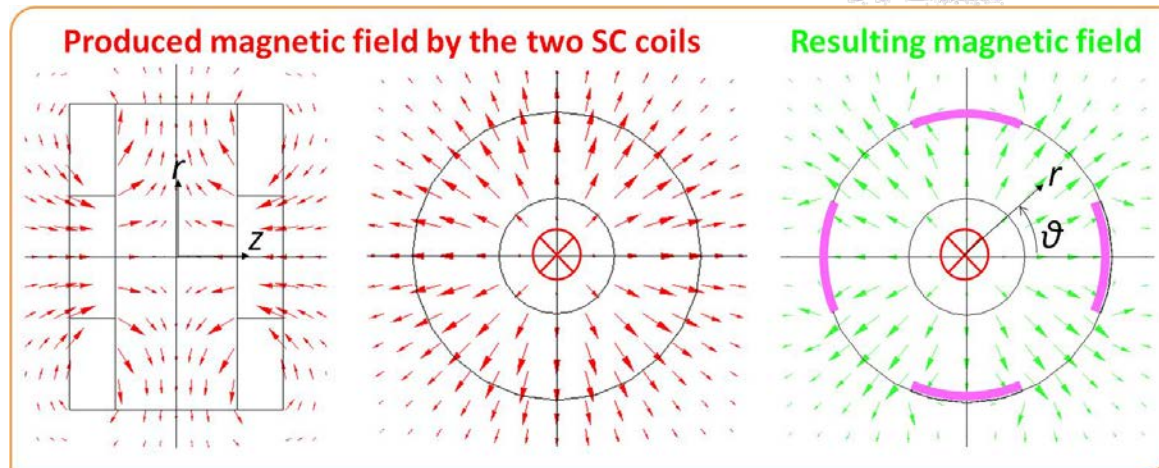
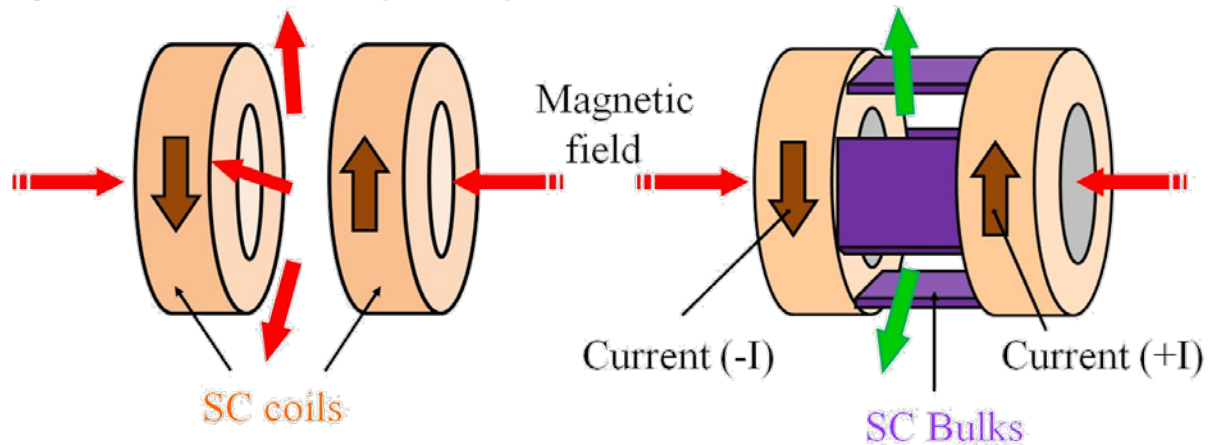

1st - study of an inductor in 2002



Coils:

- NbTi wires
- 260 A
- 880 turns

- (1) Coils
- (2) YBaCuO HTS bulks
- (3) Protection resistor
- (4) Hall probe connections

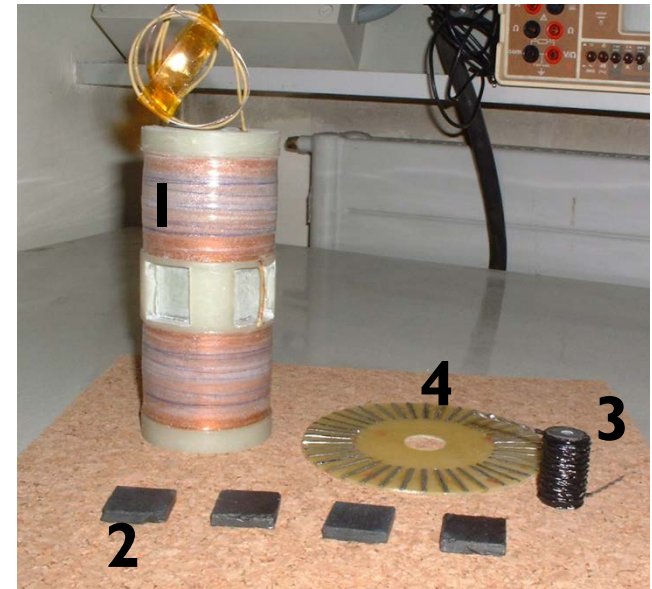

2nd - realization in 2006

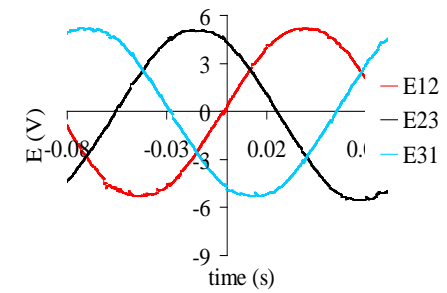

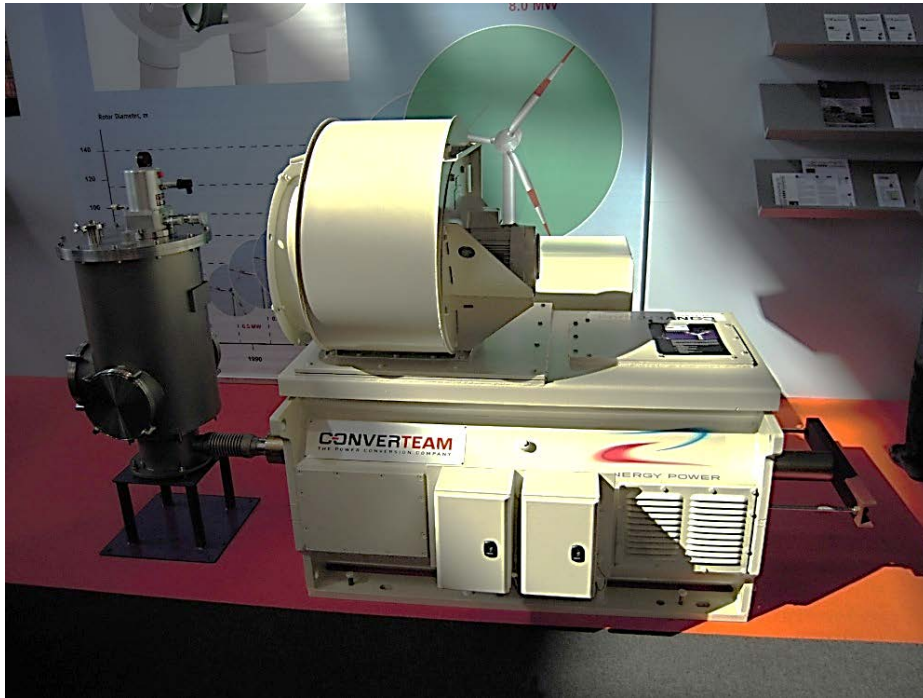

ULCOMAP Project in 2008



| | | |
|----------|-------------------------|--------------|
| 250 kW | 2 poles pairs | HTS inductor |
| 1500 rpm | 50 Hz | Bi 2223 |
| 400 V | $X_d : 0.22 \text{ pu}$ | 30 A |
| 360 A | $X_q : 0.1 \text{ pu}$ | 30 K |

- Zenergy Power GmbH
- Werkstoffzentrum Rheinbach GmbH
- Futura composite
- Converteam (now GE)
- Silesian University
- University of Nancy

ULCOMAP Project

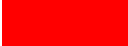
-  Vacuum of the rotor
-  Vacuum of the cryocooler
-  Gas Ne
-  Liquid Ne

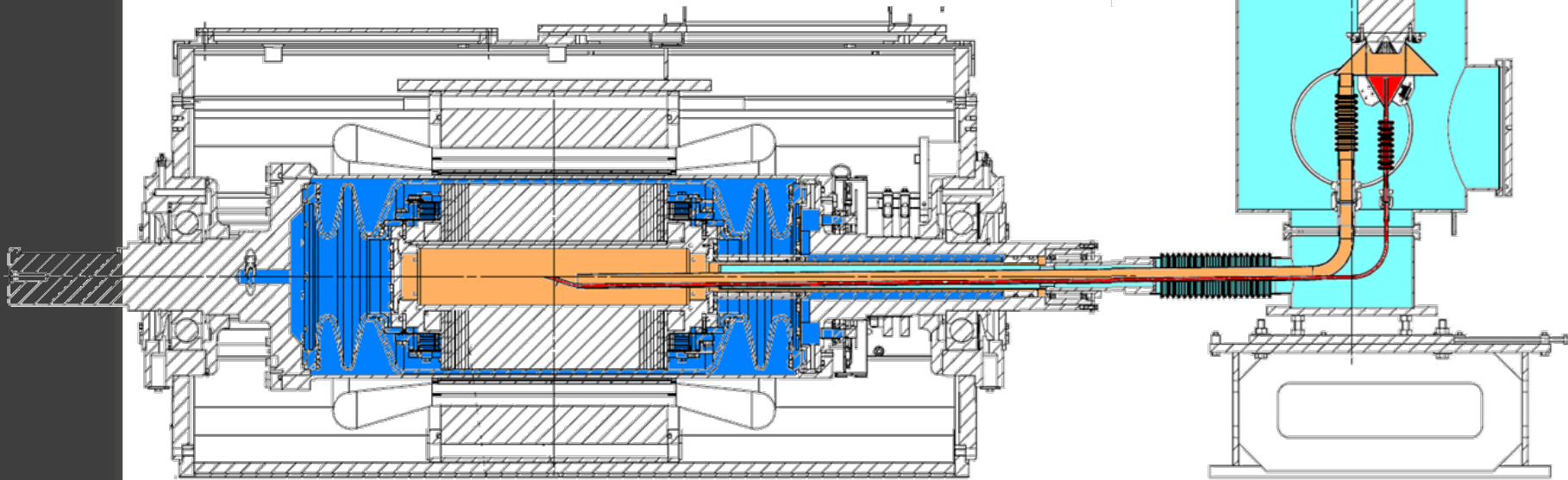

ULCOMAP Project

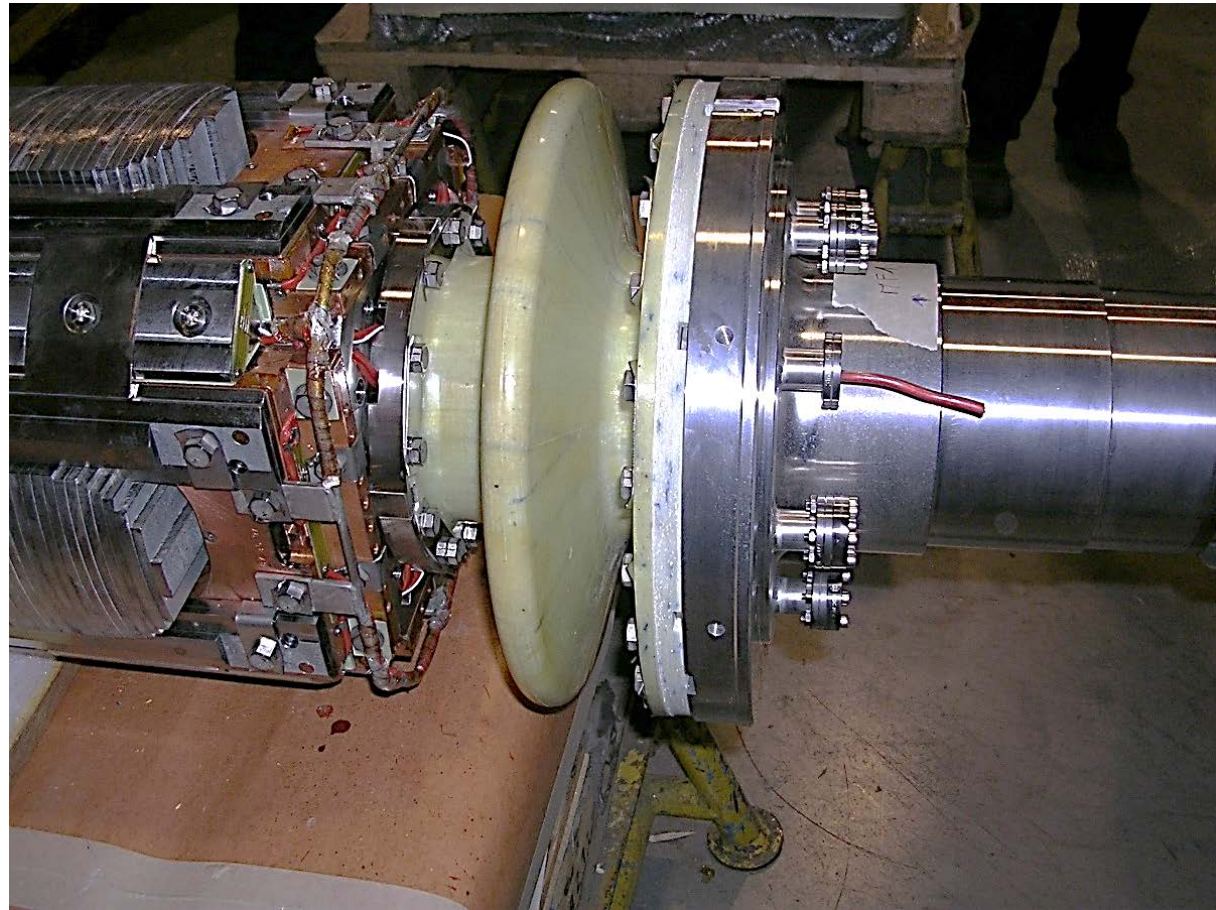

ULCOMAP Project

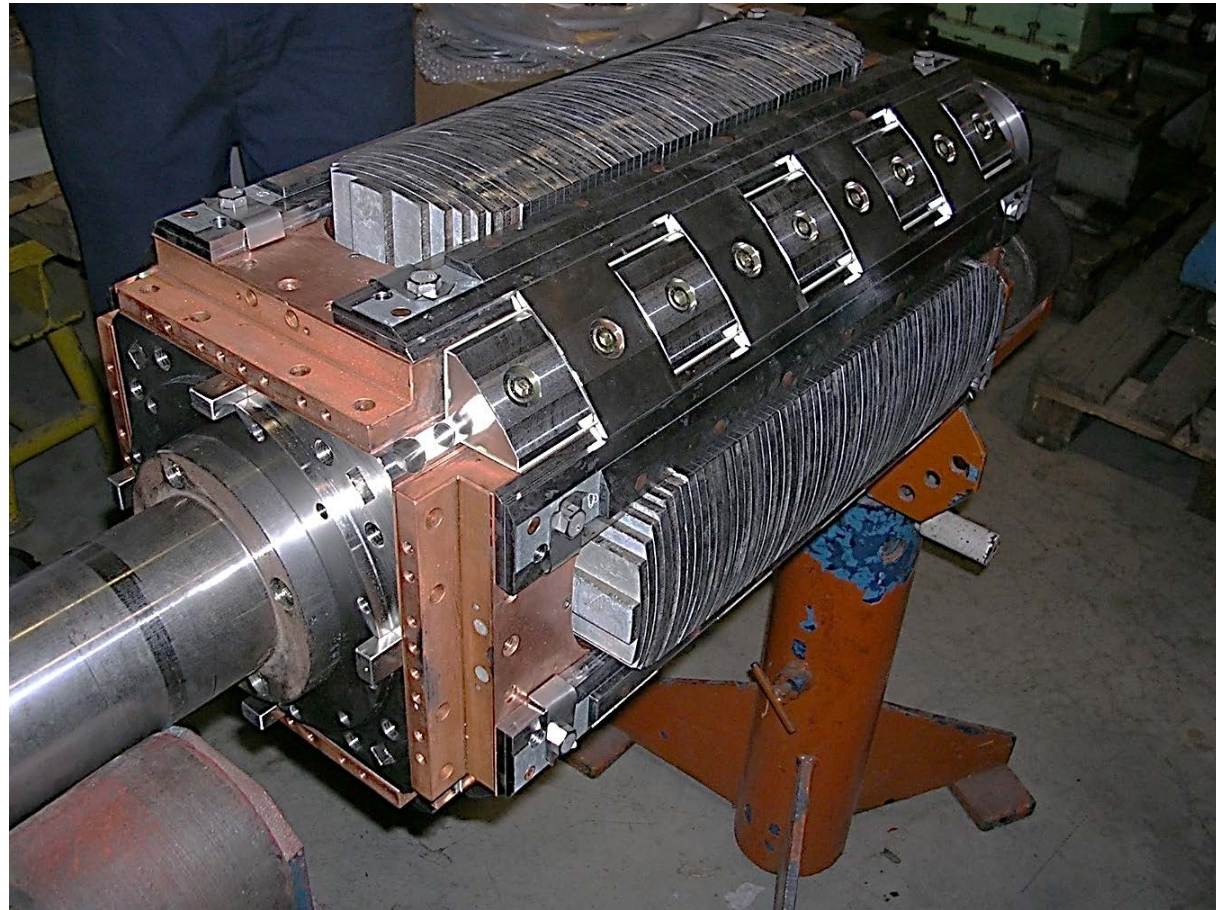

ULCOMAP Project

→ Total weight: 2 776 kg, Power density: 90 W/kg

| | 3rd October 2008 test | | 9th October 2008 test | | |
|---------------------------------------|-----------------------|-------|-----------------------|-------|--------------|
| Rotation speed N (rpm) | 1000 | | 1500 | | |
| i excit (Amp. d.c.) | 10 | 29 | 15 | 28 | 32.4 |
| U stator (V rms between phases) | 104.3 | 249.8 | 224.7 | 372.2 | 401.7 |
| I stator (A rms)) | 124.2 | 248.5 | 248.3 | 331.4 | 354.5 |
| Reactive power (KVA) | 3.16 | 15.16 | 13.6 | 30.1 | 34.8 |
| Active power at terminals (KW) | 22.2 | 106.4 | 95.7 | 211.5 | 244.2 |
| Cos. Phi (p.u.) | 0.99 | 0.99 | 0.99 | 0.99 | 0.99 |
| Voltage Total Harmonic Distorsion (%) | | 1.4 | | | |
| Current Total Harmonic Distorsion (%) | | 4.8 | | | |
| Shaft power (KW) | | | | 211.5 | 251.3 |
| Efficiency % | | | | 97.1 | 97.2 |



New kind of axial HTS motor including a superconducting magnetic coupling for naval propulsion

June 2014 – B. Dolisy's thesis

Motor principle

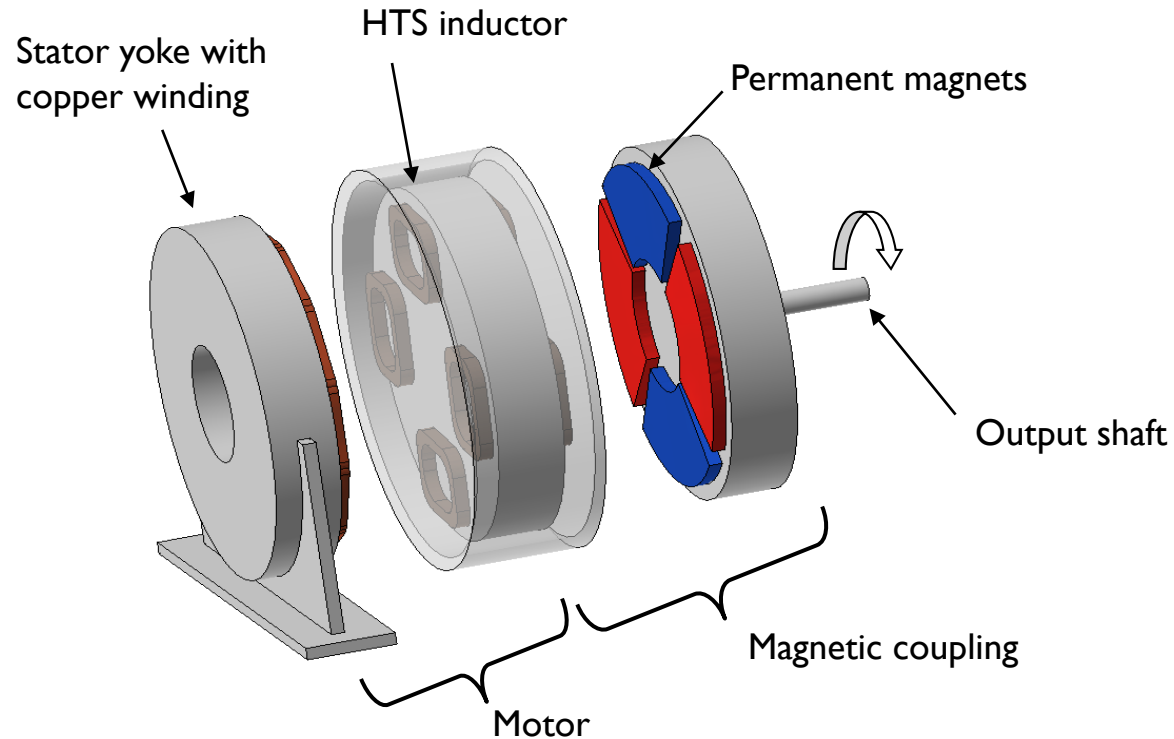

ADVANTAGES

- Increases the compactness
- Better efficiency
- Torque transmission without contact



No Torque-tubes

Design and manufacture

Goals and difficulties

Goals

- Study the behavior of the complete system (motor and magnetic coupling)
- Validate the superconducting tape modeling
- Increase the know-how of the laboratory

Difficulties

- Manufacturing the stator without ferromagnetic tooth
- Winding of the superconducting coil
- Design the rotating parts in cryogenic atmosphere

Design and manufacture

Design choices

Restrict the external motor dimensions

→ Round HTS coils

$\varnothing_{int} = 70 \text{ mm}$ minimal curvature diameter

$\varnothing_{out} = 100 \text{ mm}$

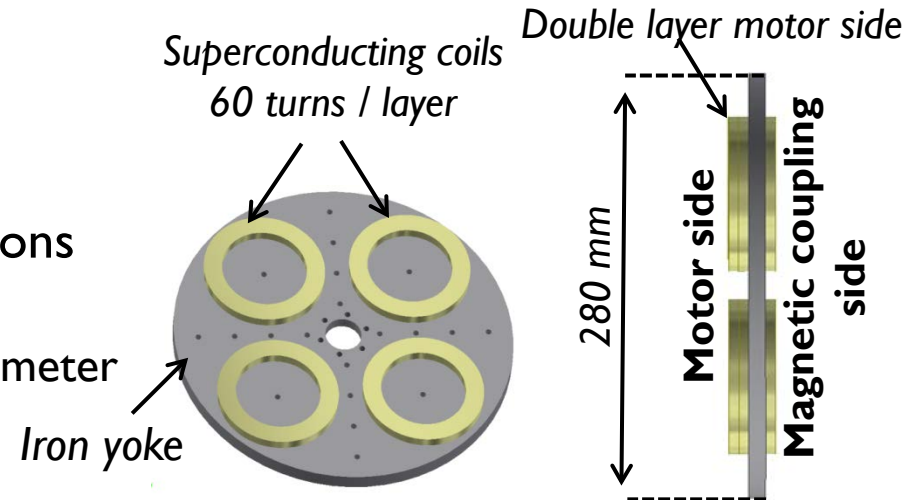

- Stator yoke with 6 copper coils

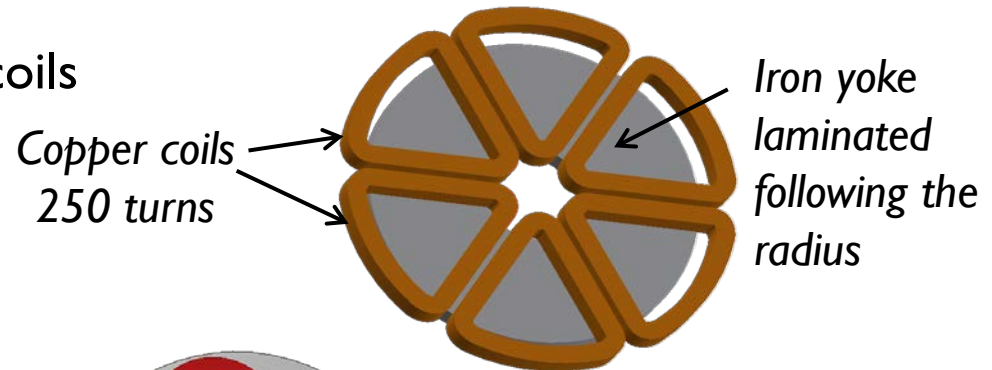

- Permanent magnets rotor

$\varnothing_{out} = 100 \text{ mm}$

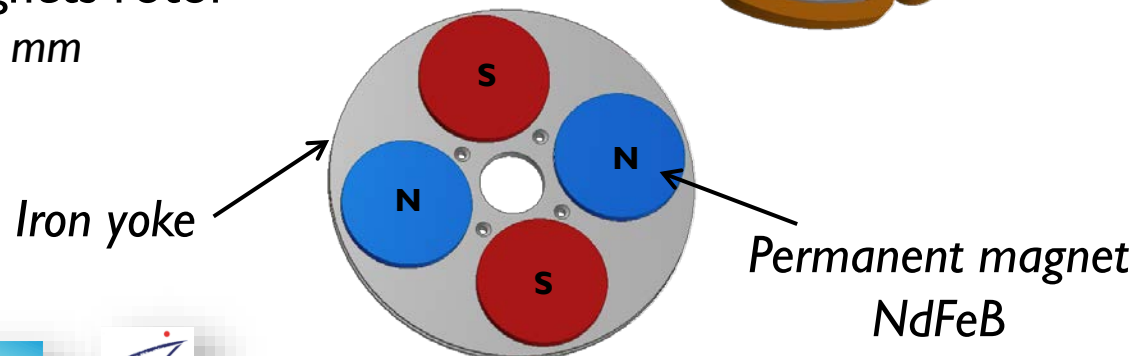

Design and manufacture

Design choices

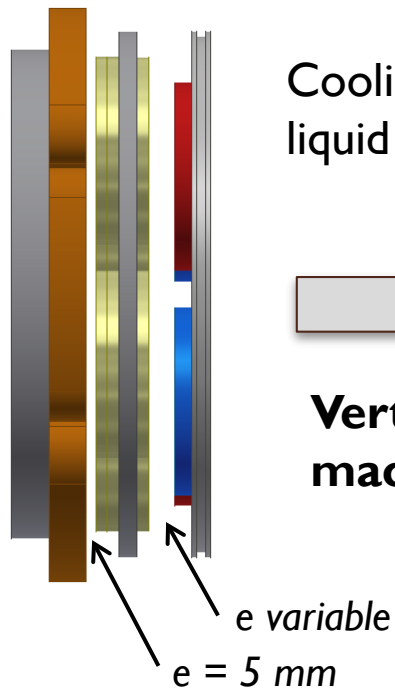

Cooling by submersion in a liquid nitrogen bath

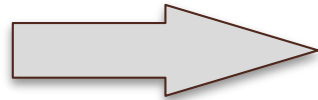

Vertical machine

Slip rings for the alimention of the inductor

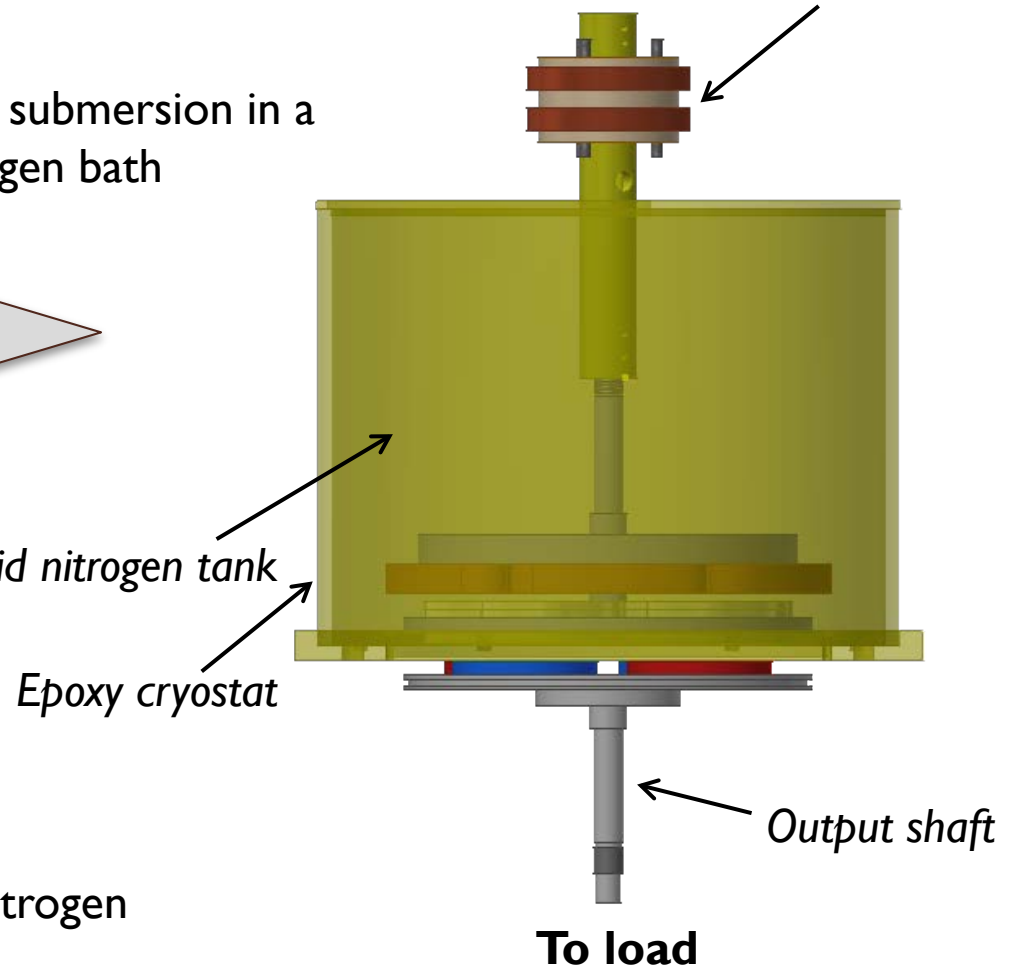

- + Efficient cooling of HTS coils
- + Easy installation
- High consumption of liquid nitrogen
- Bearings of inductor are cold
→ dry bearings

Design and manufacture

Stator with copper winding

| Description | Unit | Value |
|--------------------------|-----------------|-------|
| Thickness of a coil | mm | 15 |
| Opening of a coil | - | 60° |
| Conductor cross-section | mm ² | 0.75 |
| Number of turns per coil | - | 250 |
| Nominal current | A | 7.5 |
| Maximum power | kW | 1 |

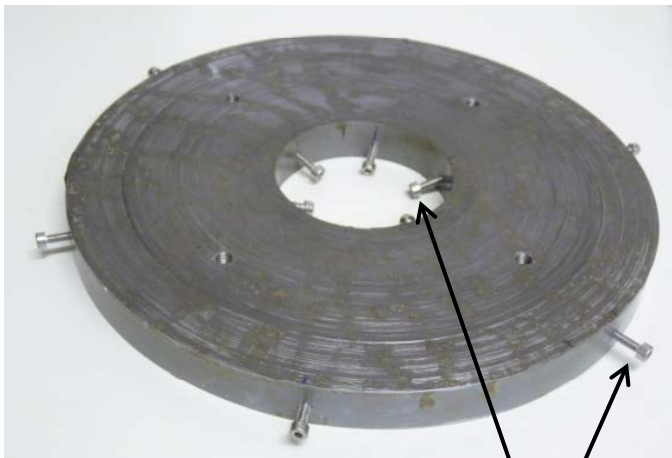

FeSi Thickness 0.3 mm
 $\varnothing_{out} = 260$ mm
 $\varnothing_{int} = 80$ mm

Anchorage of the coils



Design and manufacture

HTS inductor

BSCCO tape

| Description | Unit | Value |
|-----------------------|------|-------|
| Thickness of the tape | mm | 0.25 |
| Width of the tape | mm | 4.4 |
| Length | m | 240 |
| Ic @ 77K Self Field | A | 190 |

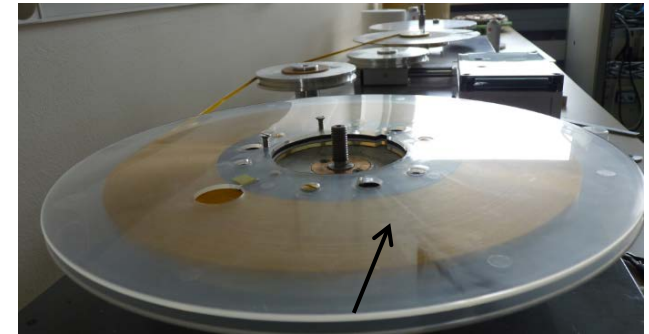

BSCCO type Hi 240 m

Characterization of a sample (10 cm) of BSCCO tape @77K

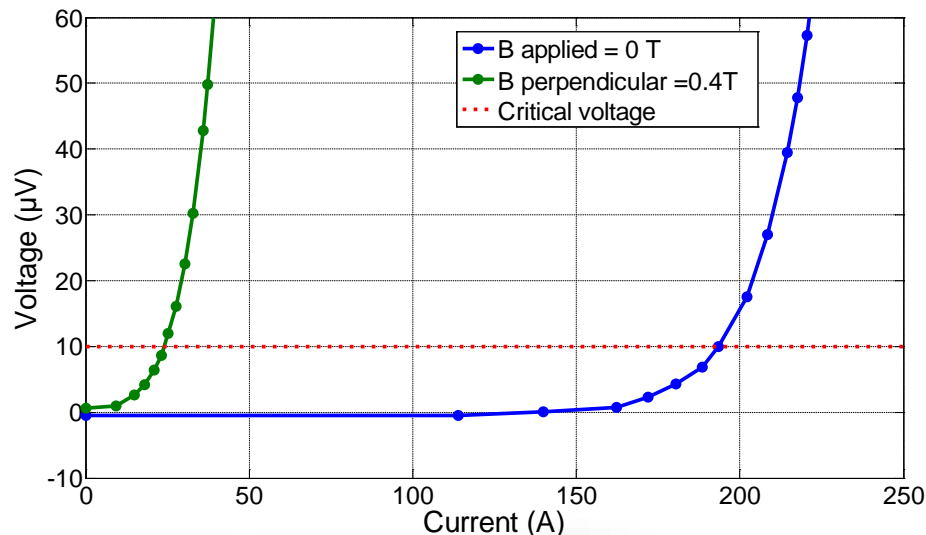

Iron Permanent Magnets BSCCO tape

Design and manufacture

HTS inductor

| Description | Unit | Value |
|---|------|-------|
| External diameter | mm | 100 |
| Internal diameter (minimal bending diameter) | mm | 70 |
| Thickness / layer | mm | 5 |
| Turns / layer | - | 60 |
| Length / layer | m | 16 |

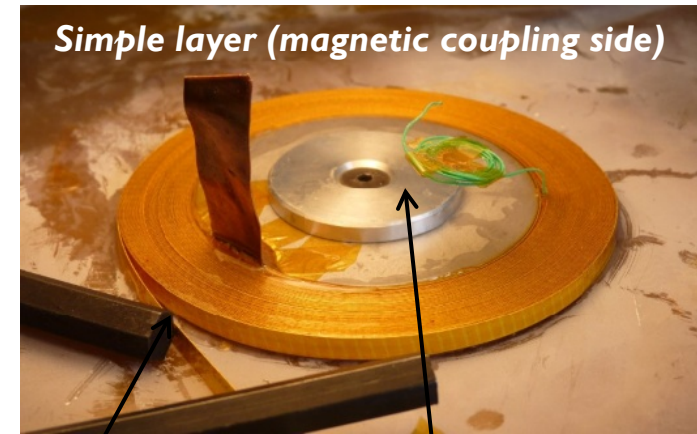

Current lead

Inox core

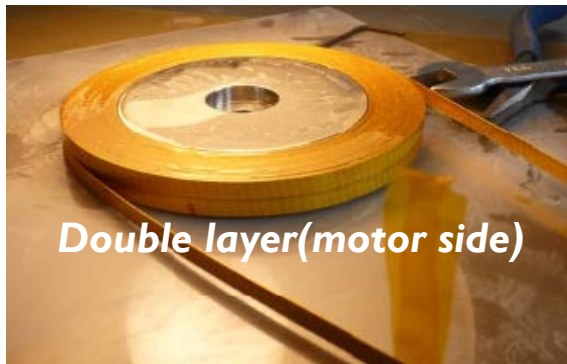

Ferromagnetic yoke



Design and manufacture

Permanent magnets rotor

| Description | Unit | Value |
|------------------------------------|------|-------|
| External diameter | mm | 100 |
| Thickness | mm | 10 |
| Remanence of the permanent magnets | T | 1.25 |

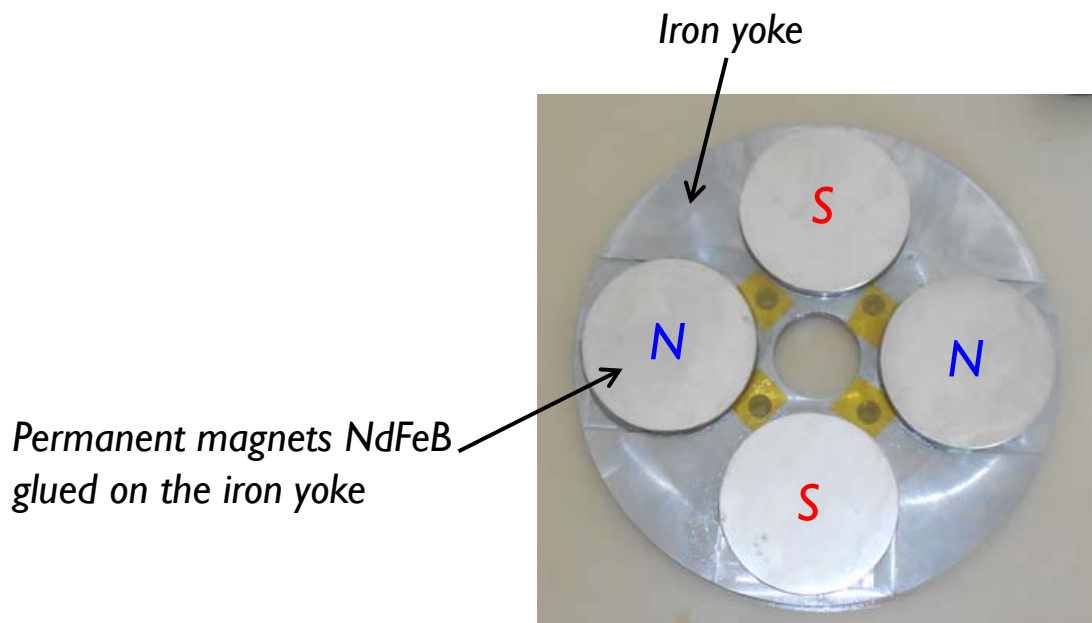

L. Belguerras, PhD Thesis, « Etudes Théoriques et Expérimentales d'Accouplements Magnétiques Supraconducteurs », may 2014.

Design and manufacture

Final assembly



Slip rings

Bearings

Stator

HTS inductor

Permanent magnets rotor

Bearings

Incremental encoder

Static torque measure

Slip rings and brushes

Cryostat

DC motor

Incremental encoder



Tests

Under rotation

Back EMF

Single voltage

$N = 500 \text{ rpm}$

$I_e = 50 \text{ A}$

Good agreement with the design

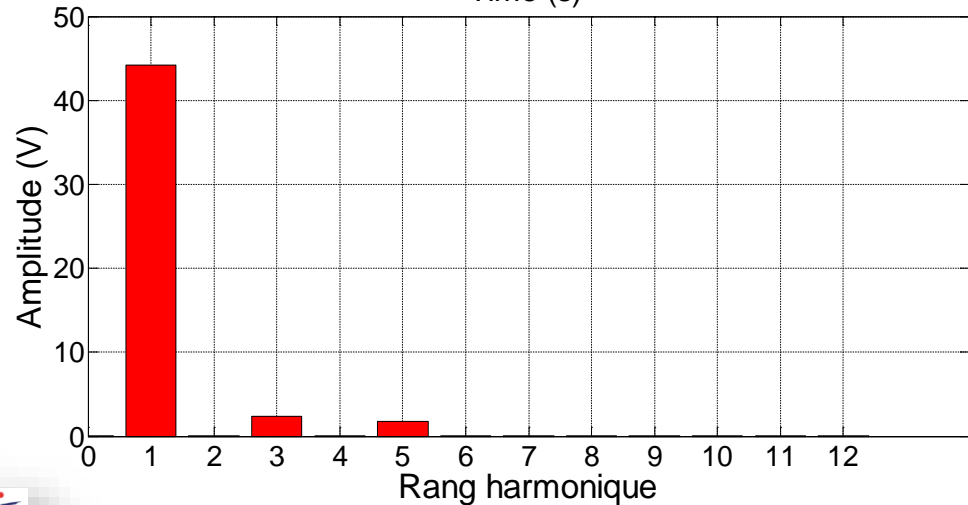
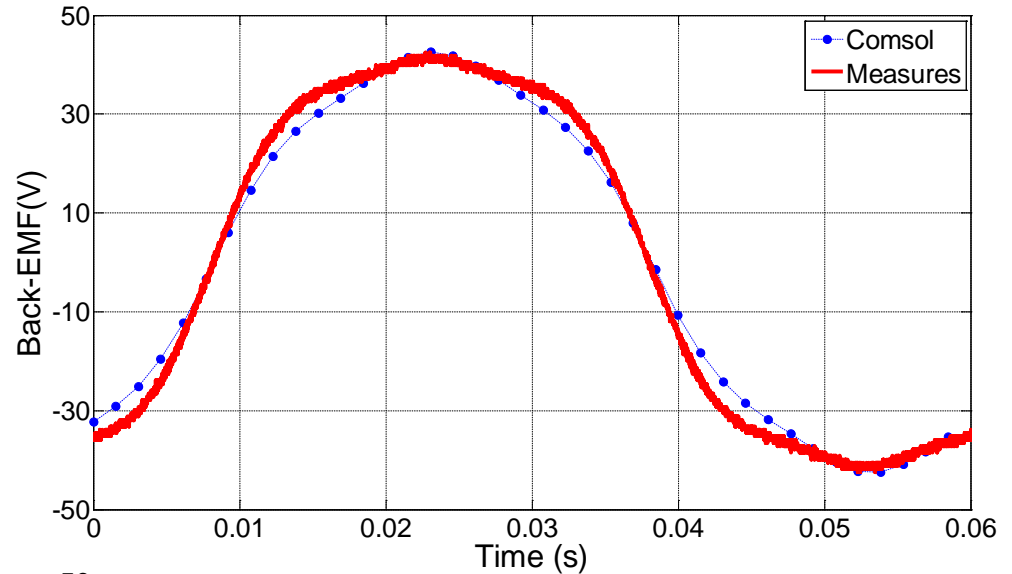

Tests

Behn-Eschenburg model

No-load test

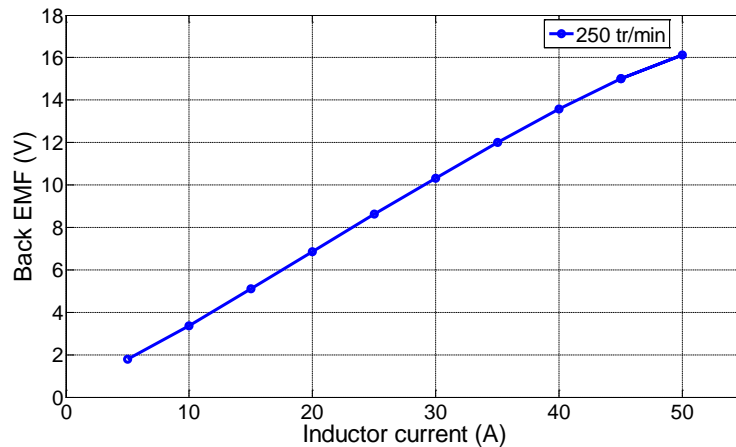
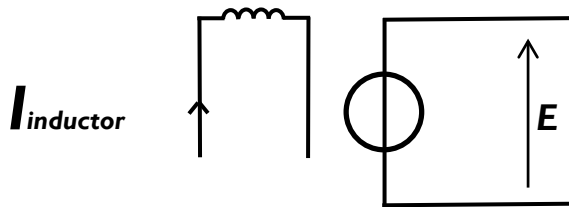

Short circuit test

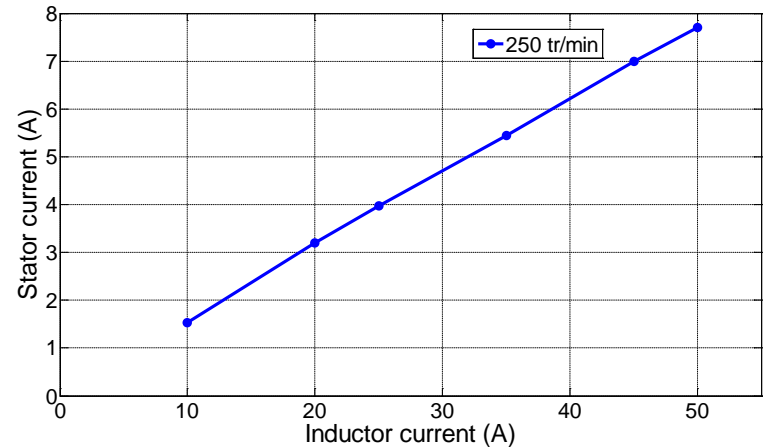
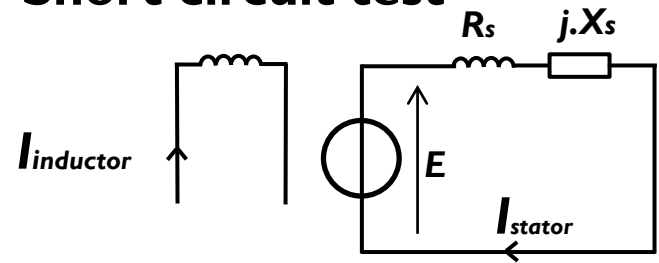

Motor parameters

$$R_s \approx 0.82 \Omega$$

$$X_s \approx 1.98 \Omega$$

$$(X_s \text{ consol} \approx 1.78 \Omega)$$



UNIVERSITÉ
DE LORRAINE



Study and realisation of a flux barrier synchronous superconducting motor

October 2014 – R.Alhasan's thesis

Motor principle

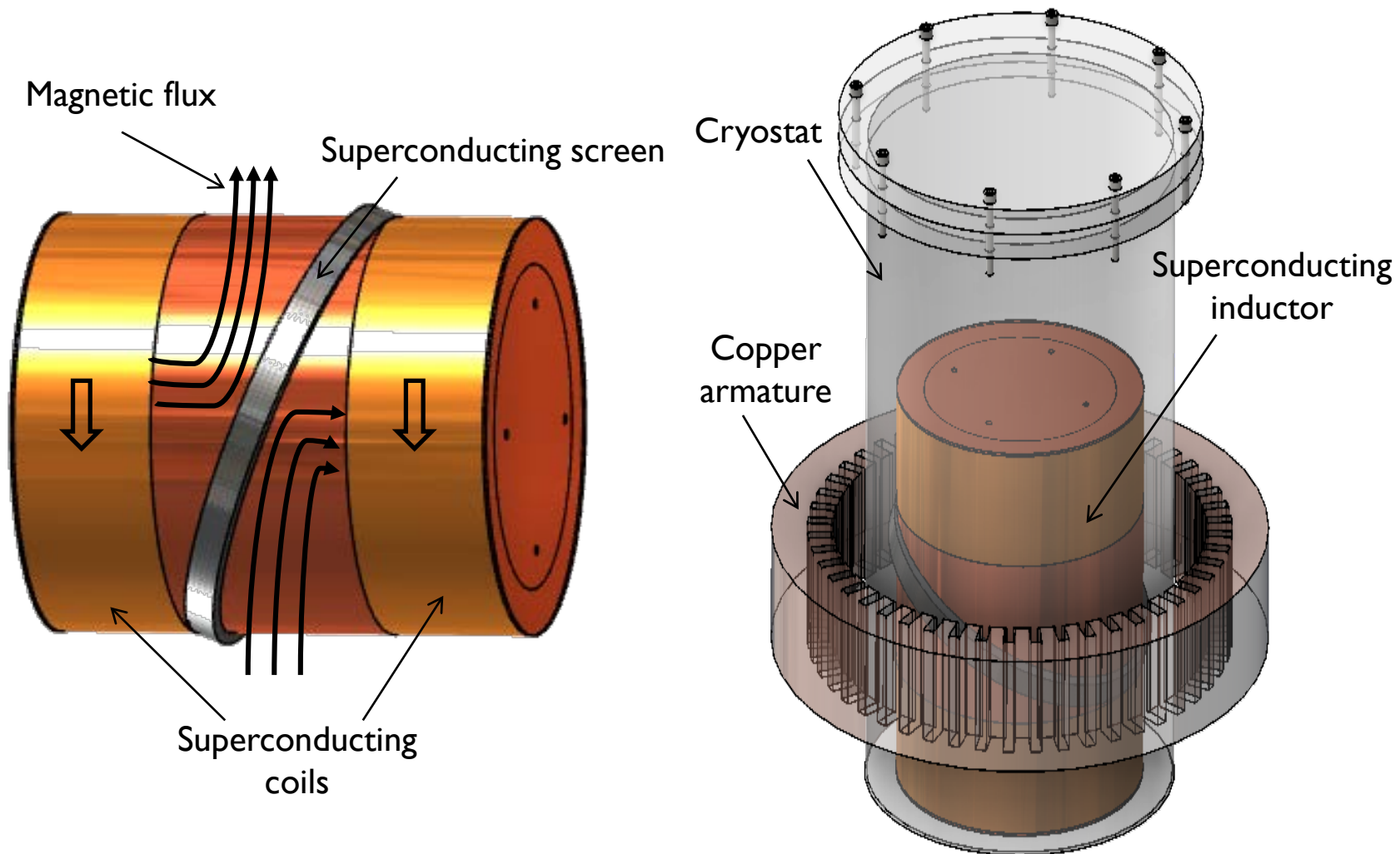

Influence of the iron

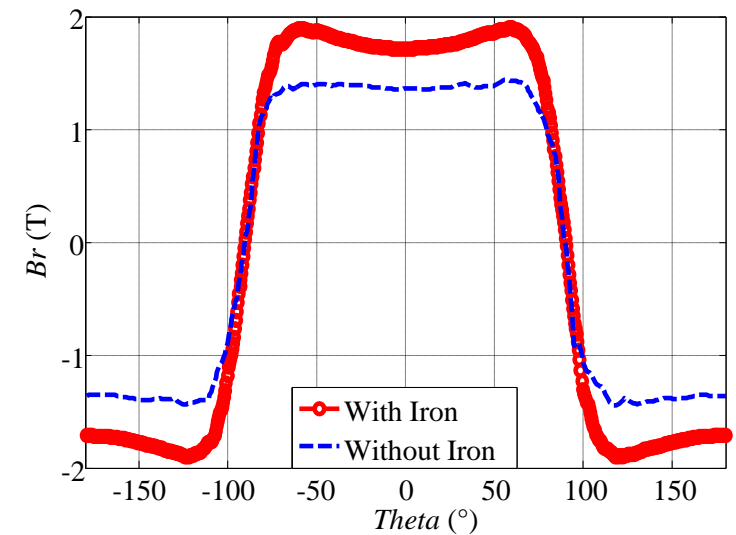
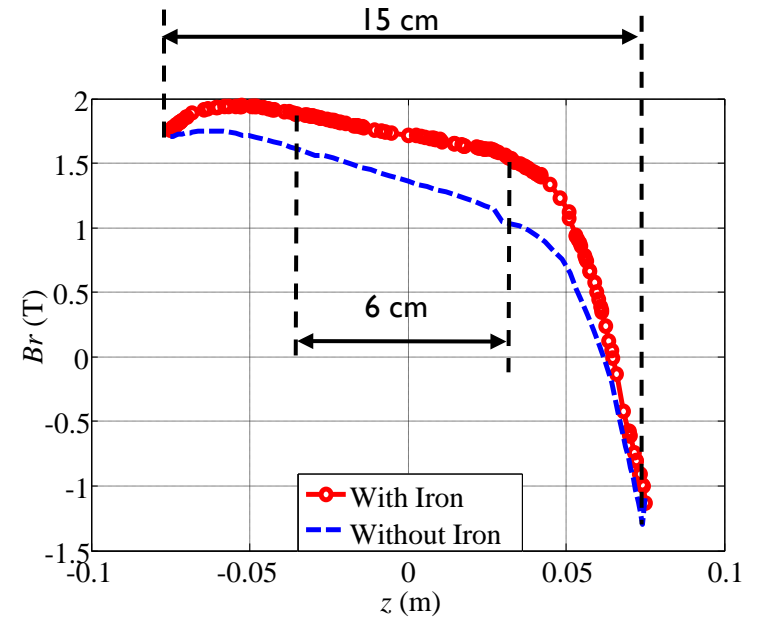
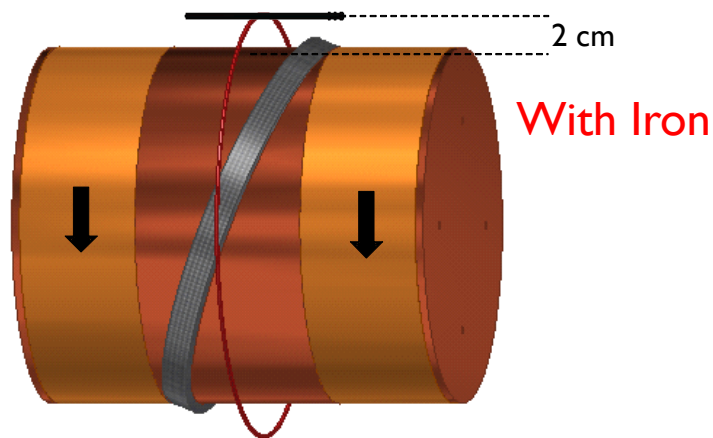
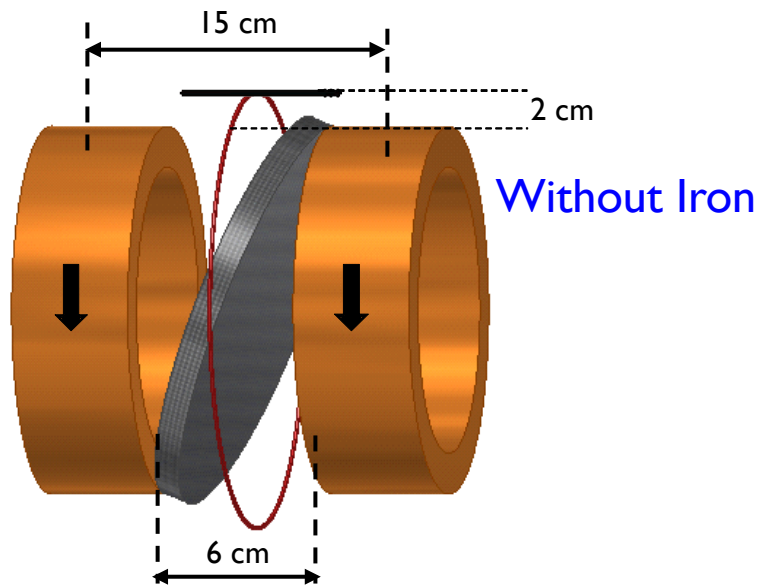

Assembly

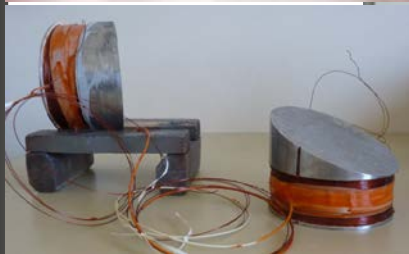
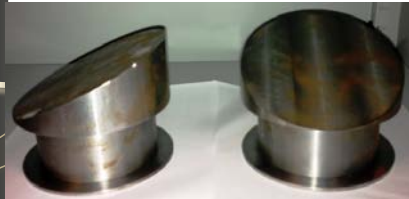

Inductor coil
NbTi (4.2K)

$$L_{\text{total}} = 17 \text{ cm}$$

$$L_{\text{active}} = 4.5 \text{ cm}$$

$$D_{\text{wire}} = 0.75 \text{ mm}$$

$$N = 850 \text{ turns}$$

Superconducting screen
YBaCuO

$$D = 15 \text{ cm}, e = 1 \text{ cm}$$

Circular Shape

Armature
Copper

$$1680 \text{ turns}$$

$$S_{\text{wire}} = 0.4 \text{ mm}^2$$

Assembly

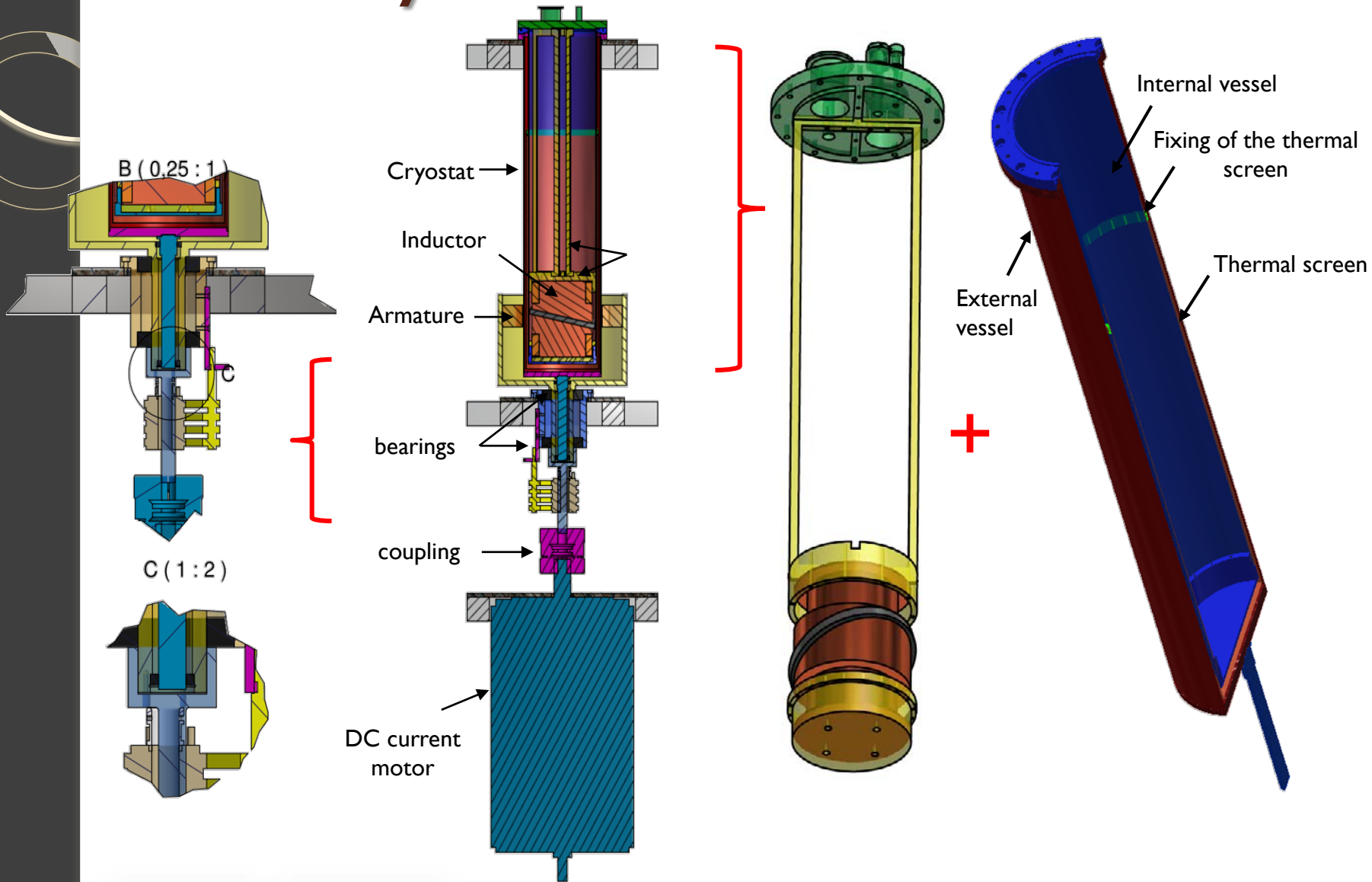

Assembly



Tests

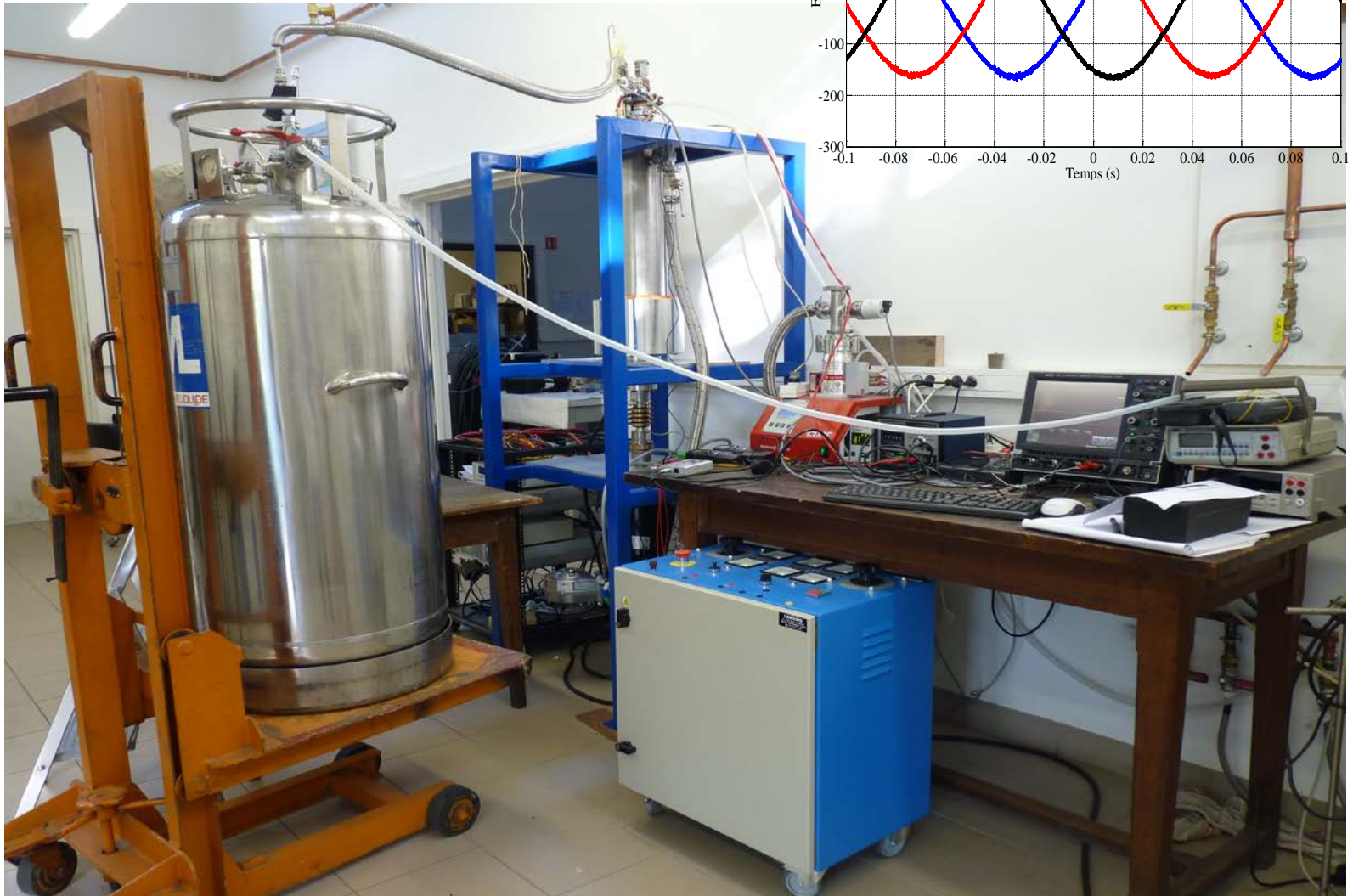

Summary

- GREEN has a good expertise in superconducting motors
 - AC losses measurements/modeling are linked to this topic
 - The characterization of tapes is also needed
 - Magnetic coupling is a kind of synchronous machine
- Most of the motors developed by the GREEN involve bulk superconductors
 - They can trap or screen very high magnetic fields
 - They are the key for a major technological advance

Outline - High magnetic flux generation with superconductors

- How high?
- For what purpose?
- How it works?
- How we made it?
 - Example of field cooling on MgB2 measurements
 - Pulsed Field Magnetization on YBCO @ 77 K

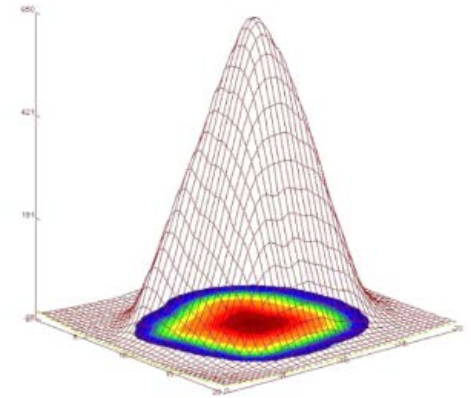

How high?

Resin
impregnated
YBCO pellets

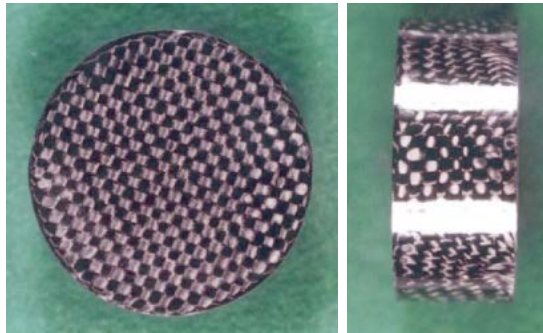

- 15 T can be trapped at 30 K using field cooling method
- The behavior is different from permanent magnets:
 - Permanent magnets operate at “constant flux”
 - HTS operate at “constant current”

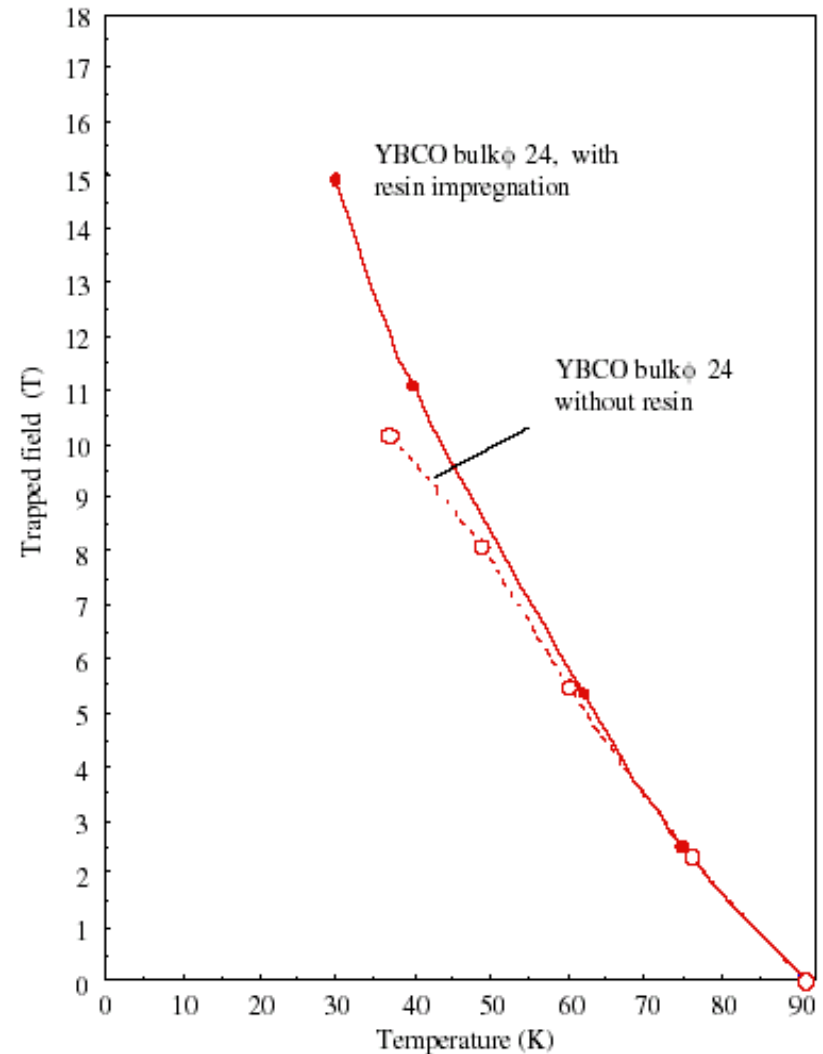

How high?

Resin
impregnated
YBCO pellets

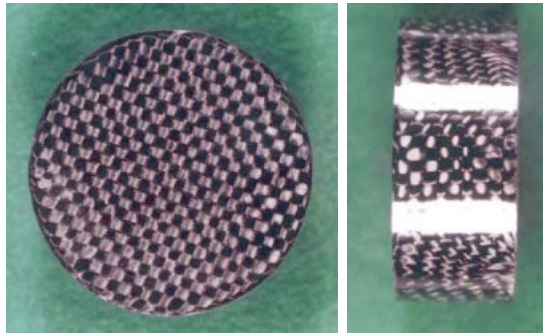

- Record: 17 T trapped
- Higher fields are theoretically possible
- Cryo-magnets are promising, but they are difficult to implement

M. Tomita et M. Murakami, « High-temperature superconductor bulk magnets that can trap magnetic fields of over 17 tesla at 29 K », *Nature* 421, pp. 517-520, 2003.

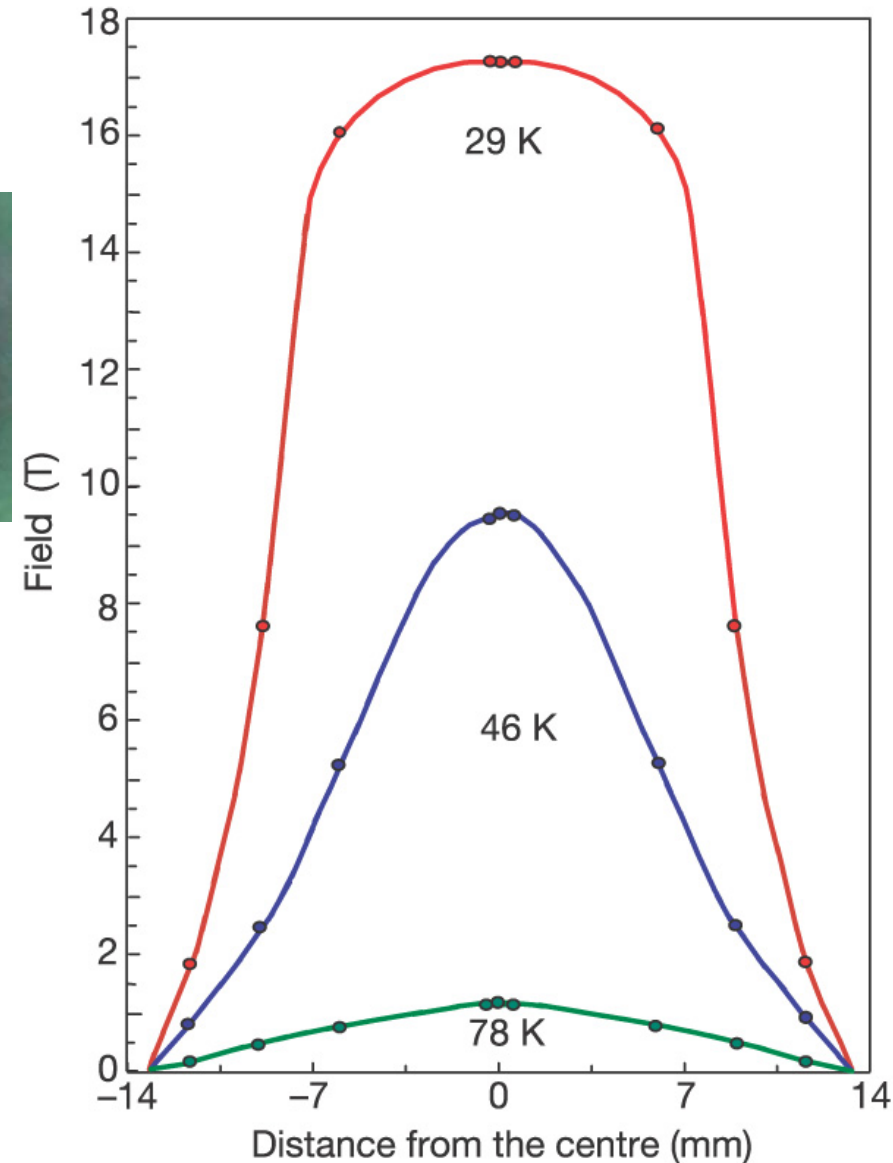

For what purpose?

- Electrical machines

Design of bulk-HTS synchronous motor

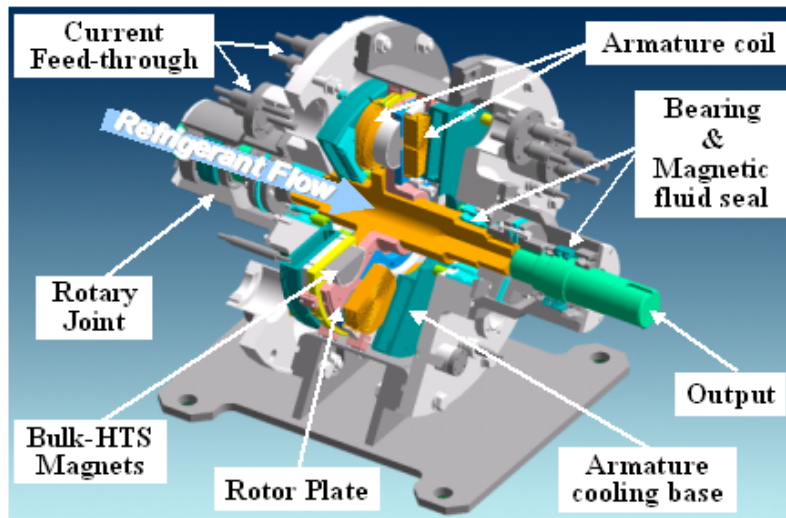

H. Matsuzaki et al., « HTS Bulk Pole-Field Magnets Motor With a Multiple Rotor Cooled by Liquid Nitrogen », *IEEE Trans. Applied Superconductivity* 147 (2), pp. 1553-1556, 2007.

- Magnetic coupling

- Replacing PM by YBCO bulks

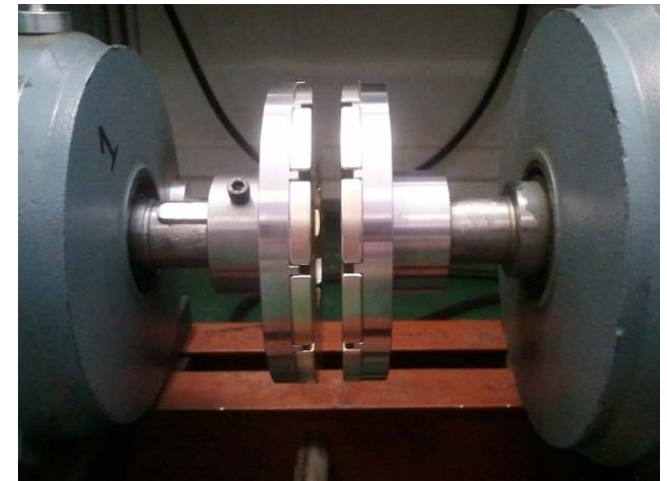

T. Lubin et al., « Experimental and Theoretical Analyses of Axial Magnetic Coupling Under Steady-State and Transient Operations », *IEEE Trans. Industrial Electronics* 61 (8), 2014.

How it works?

- Lenz's law:
 - When a variation of the magnetic field is applied to a superconductor, there are induced currents
 - Even if the applied field is null, the currents remain indefinitely in the superconductor producing a magnetic field like a coil
 - The interaction of the induced currents with a perpendicular magnetic field, (e.g. PM) results in a force according to the Laplace formula $F_z = J_\theta \times B_r$



↪ Levitation principle

How we made it?

- Cryocooler capabilities
 - For cooling the HTS down to 10 K
 - 70W @ 30 K (CH 110, 45 cm bore)
 - 2W @ 10 K (CH 204 with 2 stages)
 - 0.1W @ 5 K (ARS 202 with 2 stages)
 - The HTS with the cryocooler is put inside the bore of the LTS coil



How we made it?

- Cryogenic Hall probes array

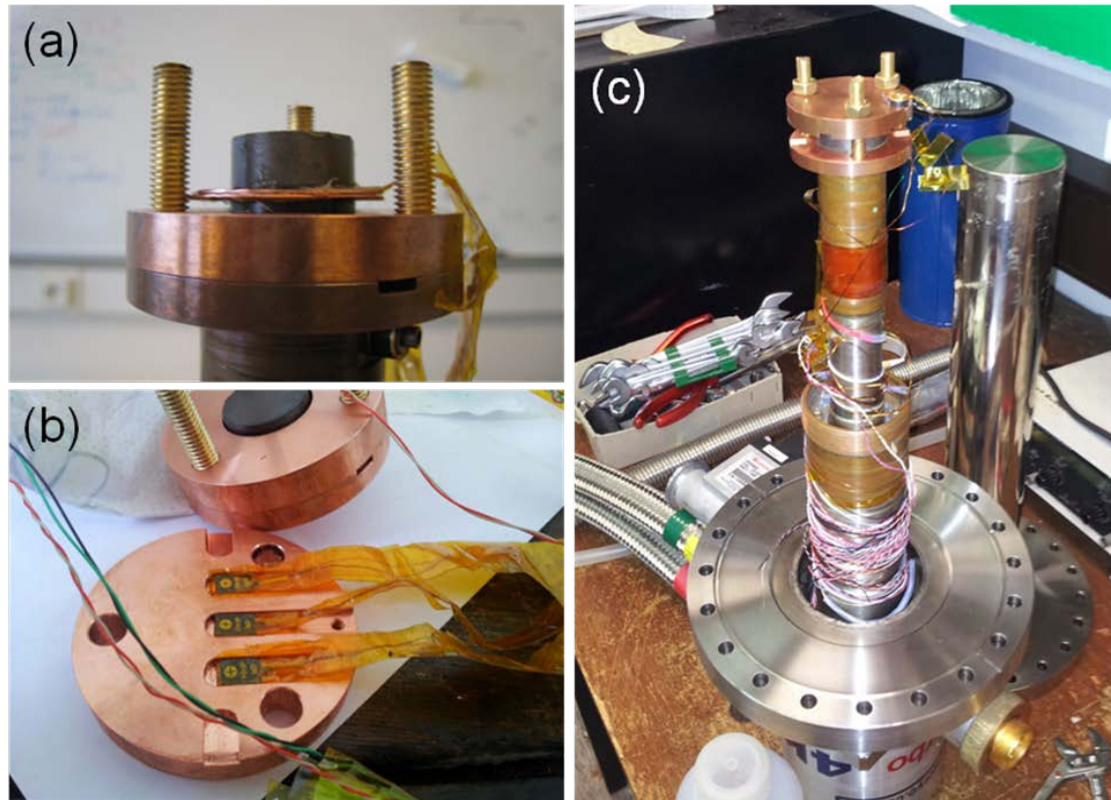

How we made it?

- By Field Cooling process using:
 - Home made LTS coil 4 T with \varnothing 10 cm bore (Nancy)
 - Oxford Instruments ± 5 T, \varnothing 7.5 cm bore (Saarbrücken)

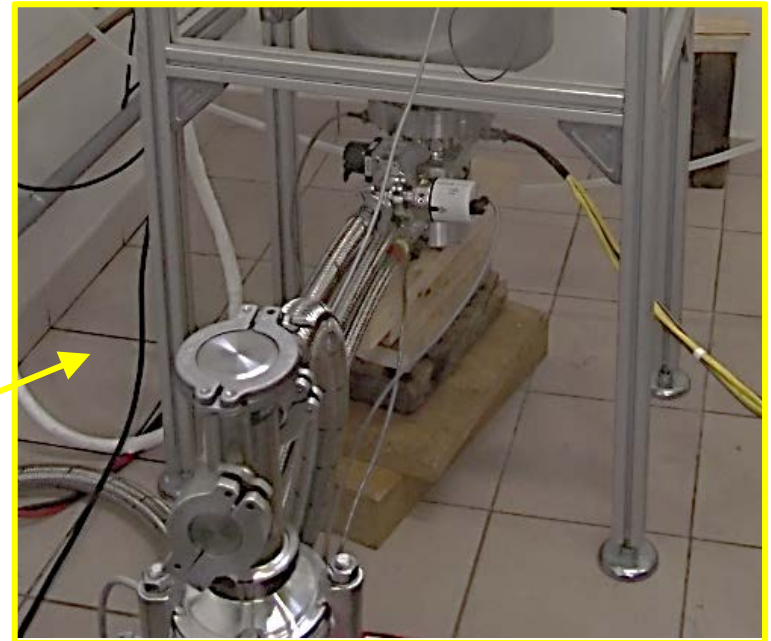
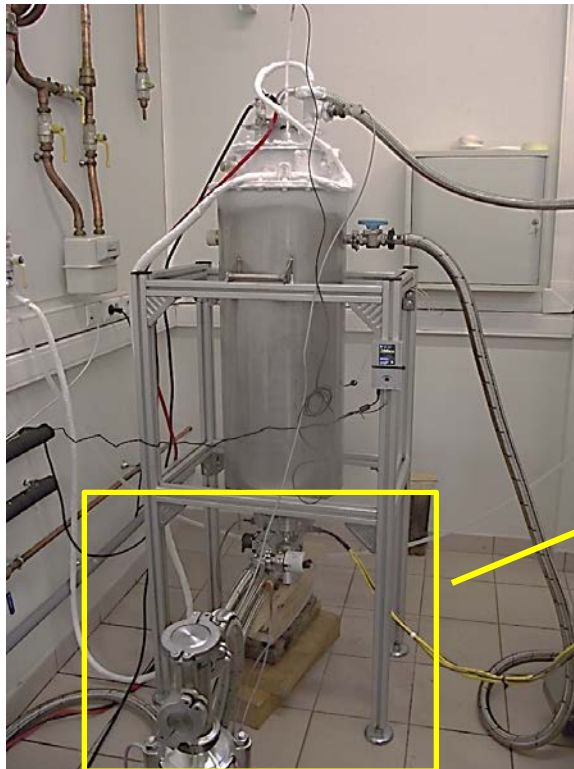

MgB2 sample with 4% Ag

Ø 20 mm

- Sweep rate influence on the flux jumps

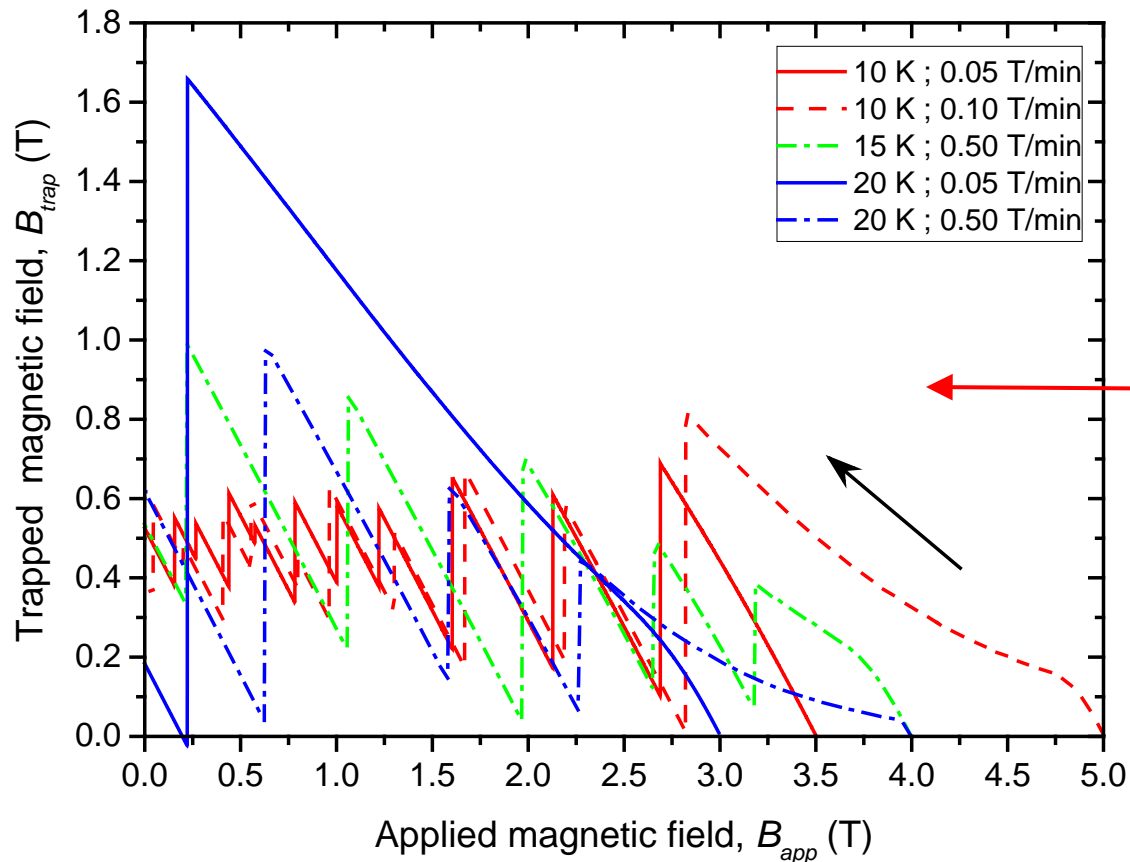

MgB2 sample produced by SPS

∅ 30 mm

- Sweep rate influence on the flux jumps

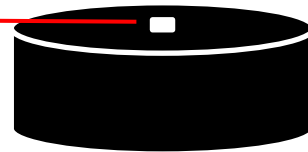
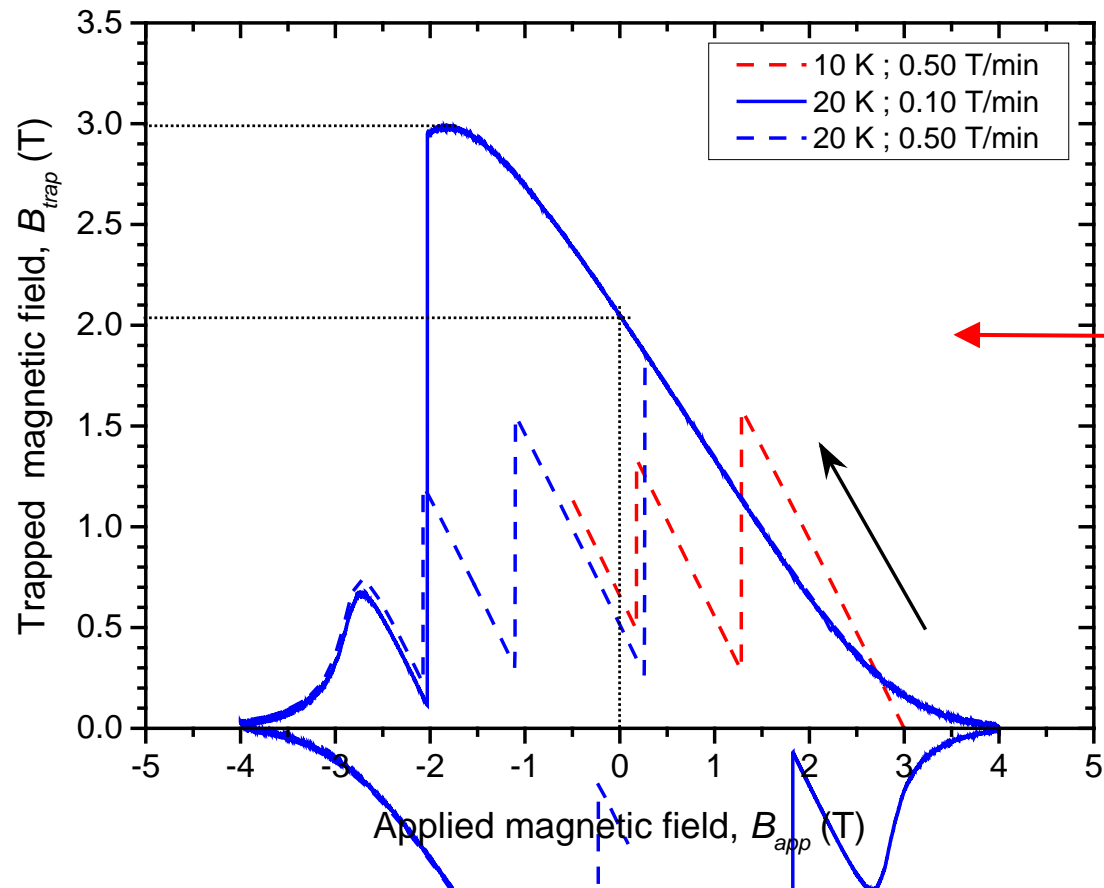

2xMgB2 samples produced by SPS

Ø 20 mm

- Higher trapped fields inside the pellet

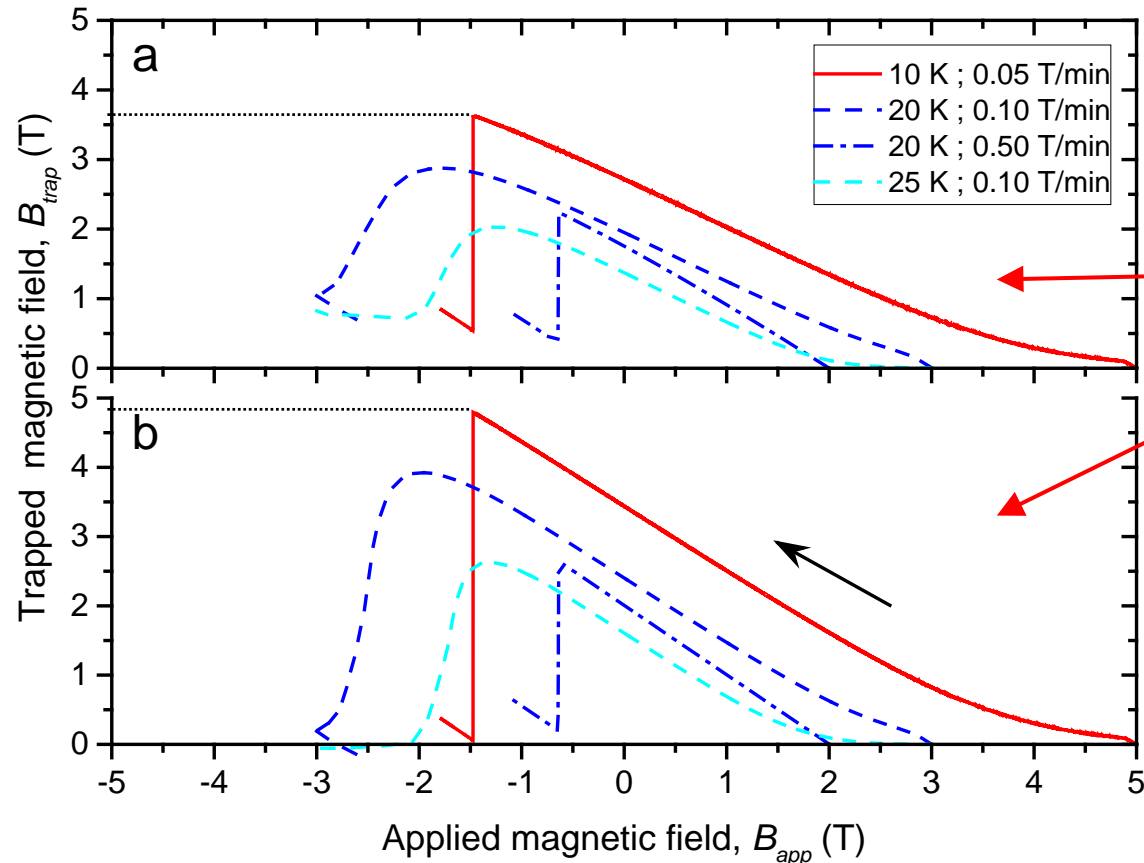

2xMgB₂ samples produced by SPS

∅ 20 mm

- Higher trapped fields inside the pellet

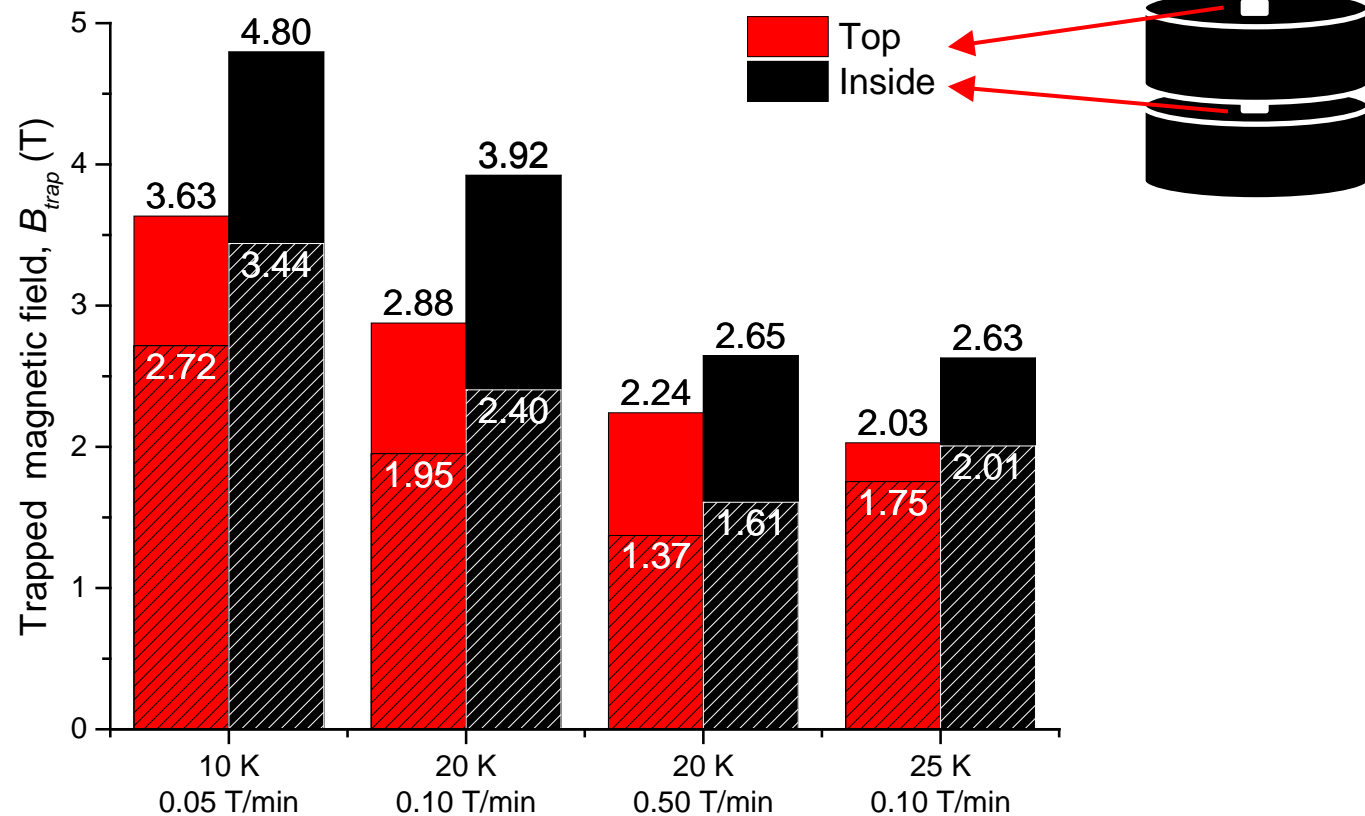

Pulsed Field Magnetization technique

- The most convenient and most common way to magnetize a superconducting pellet is to use a Pulsed Magnetic Field,
- It can generate strong magnetic fields while using a relatively small and simple coil,
- Thus, the pellet can be directly magnetized into the final application, e.g., a machine.

Experimental apparatus



220 Vac + Rectifier
350 Vdc

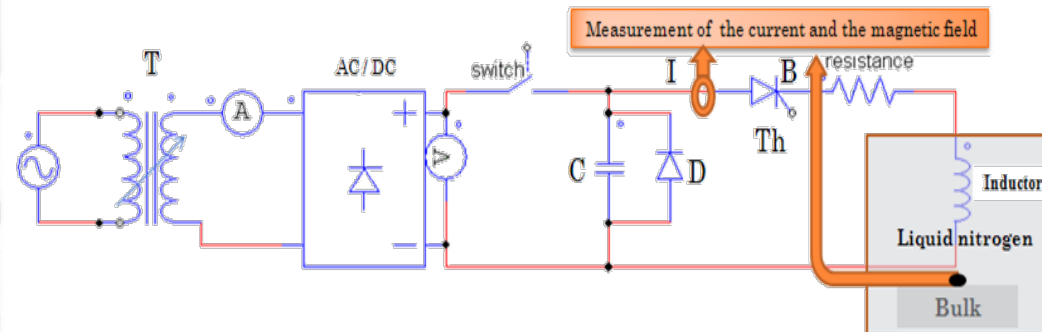

Capacitor bank
115 mF

Thyristor 16 kA max

Experimental apparatus

- PFM within an iron core:
 - To reproduce the classical motor structure
 - To increase the trapped magnetic field in the HTS

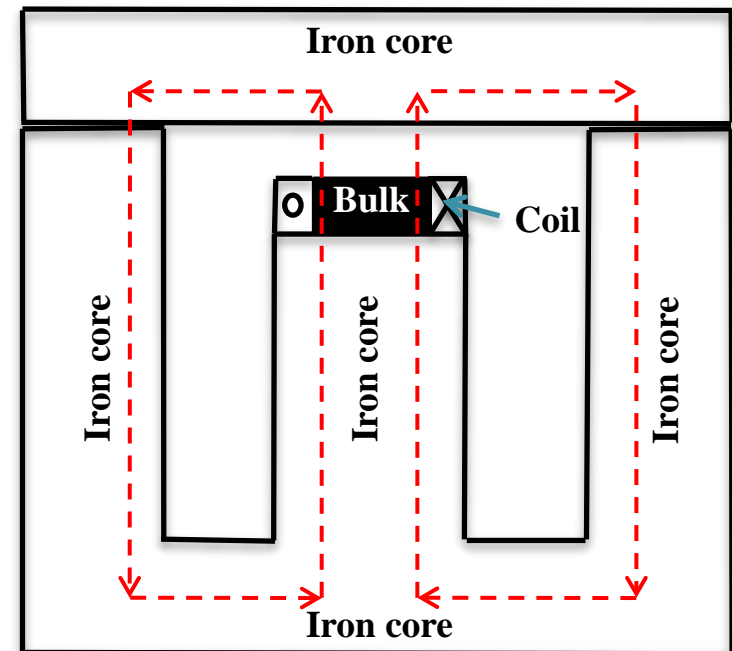

Experimental apparatus @ 77K

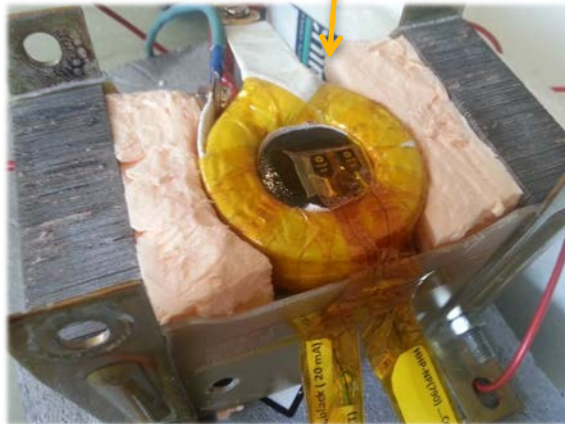
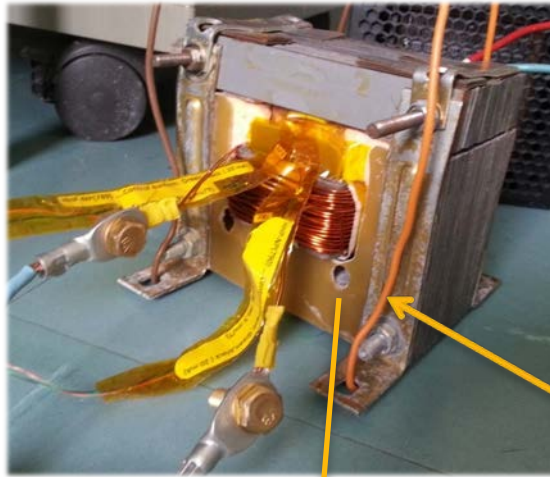

B. Gony, K. Berger et al., "Improvement of the Magnetization of a Superconducting Bulk using an Iron Core", *IEEE Transactions on Applied Superconductivity*, to be publisher, 2015.

Pulsed current and magnetic field

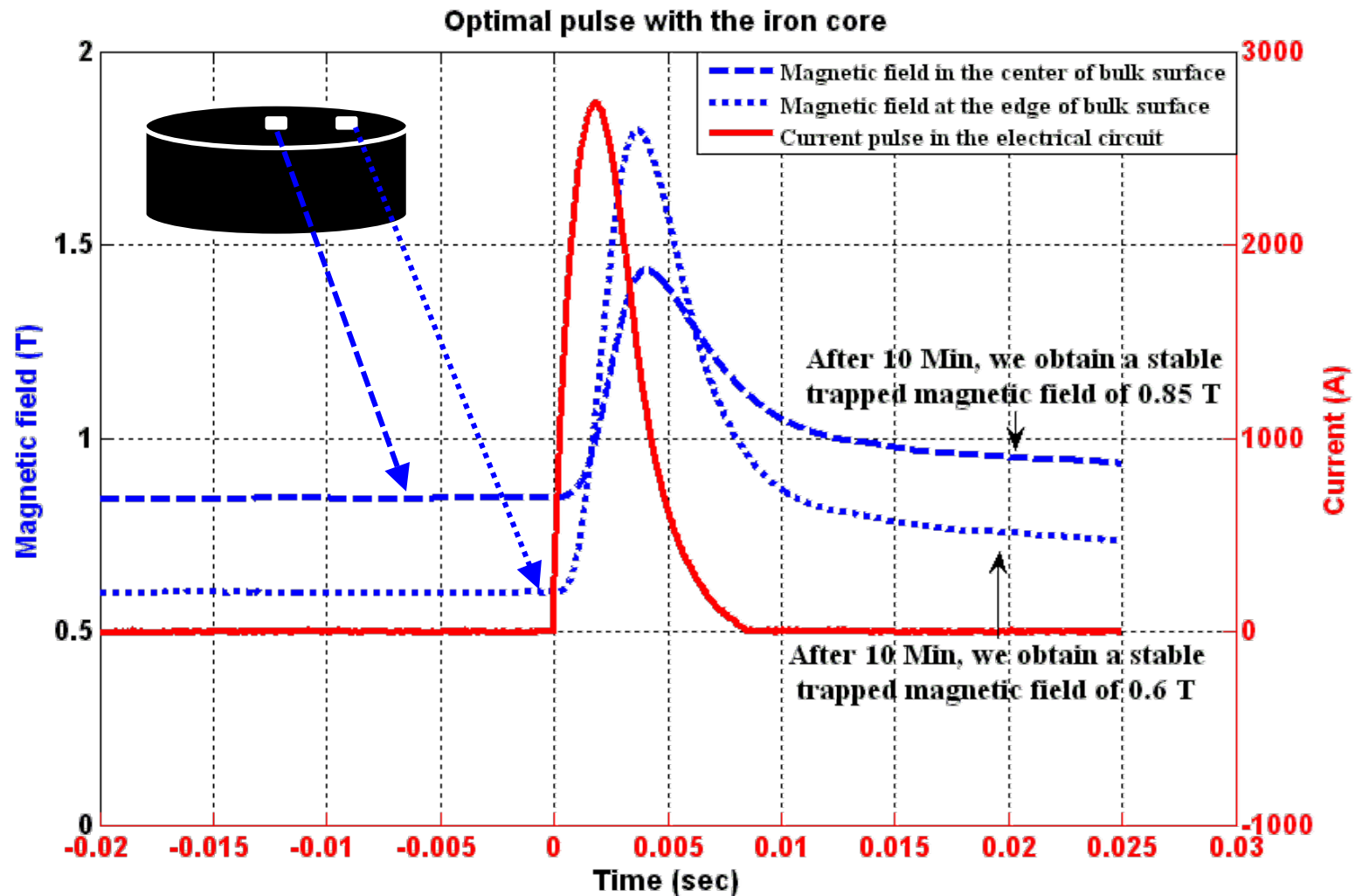

Magnetization behavior of YBCO

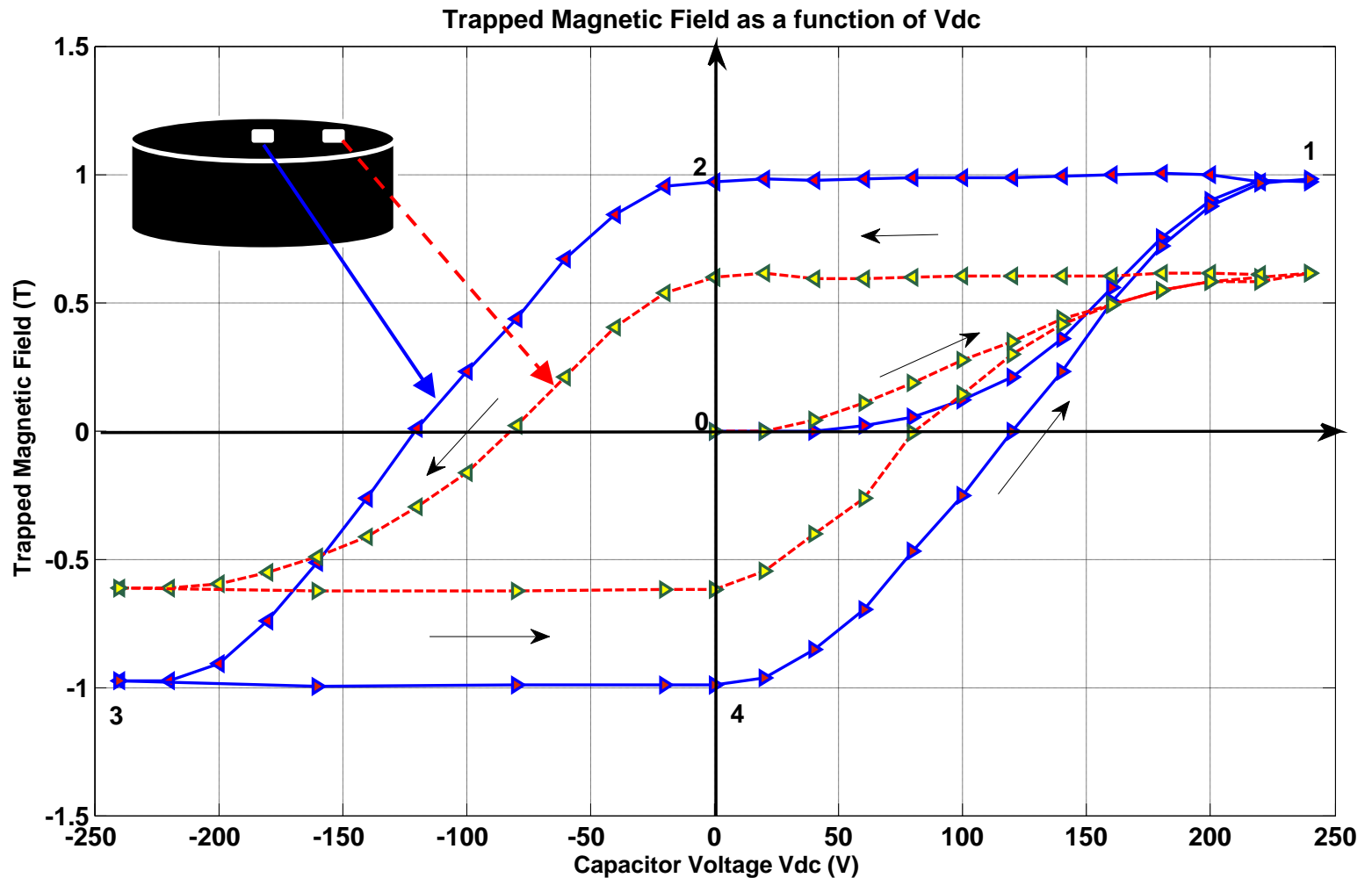

Study of the demagnetization

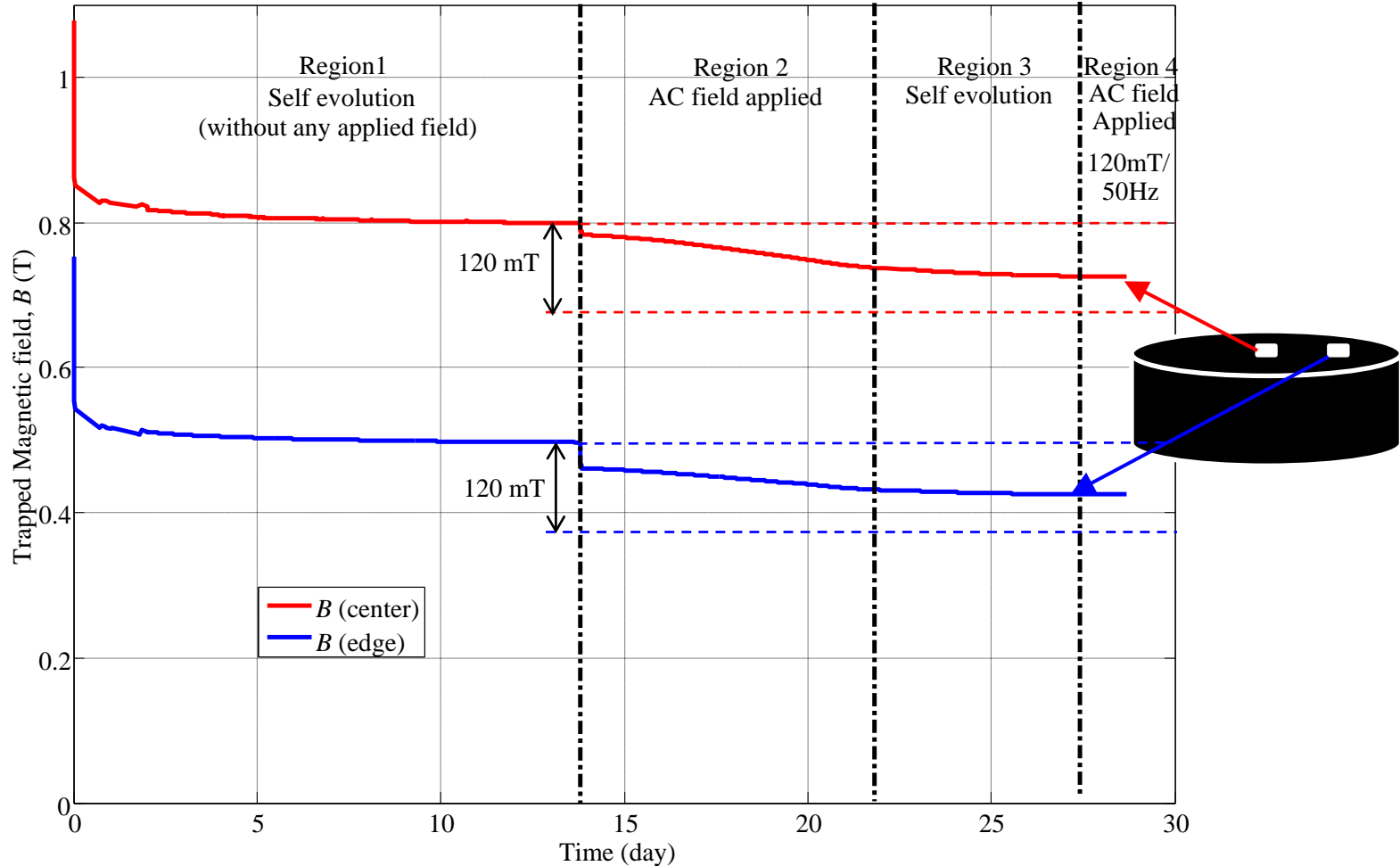

Advantages and future works on PFM

- Increased of 35% of the trapped magnetic field by using the iron core,
B. Gony, K. Berger, B. Douine, M. Koblichka, J. Lévêque.
"Improvement of the Magnetization of a Superconducting Bulk using an Iron Core.", *IEEE Transactions on Applied Superconductivity*, 2015.
- Maximal current of the discharge 40% lower with the iron core,
- The PFM with an iron core will be studied at low temperature using a CH-110 cryocooler.

New activities at the GREEN

- Using Fuel cell as a Power Supply for Superconducting Coil

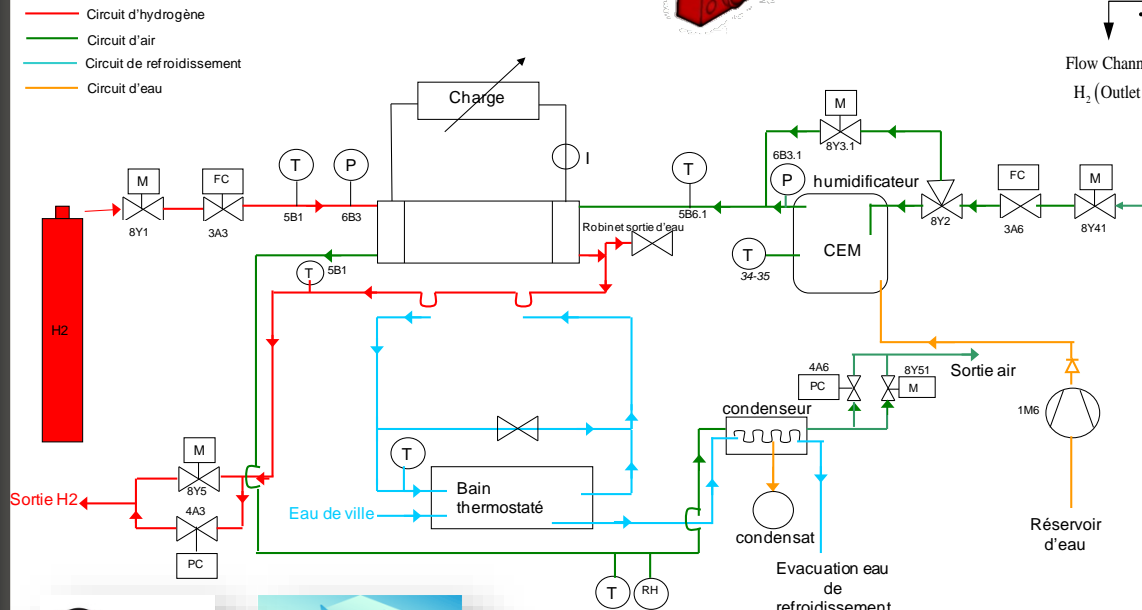
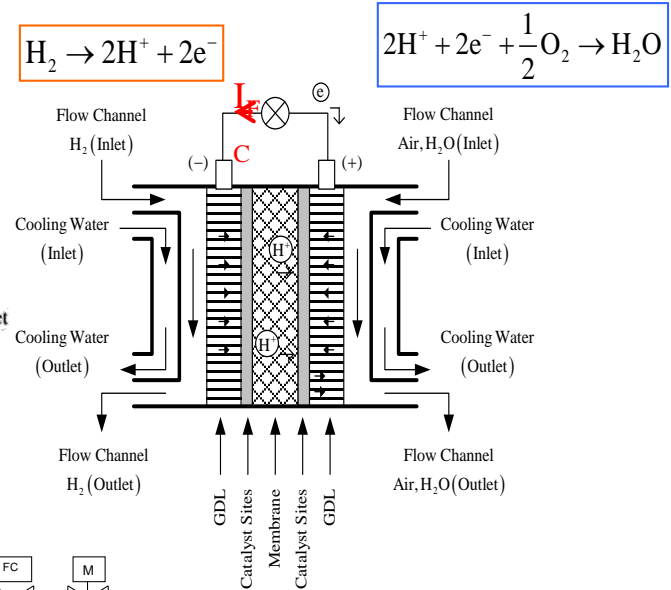
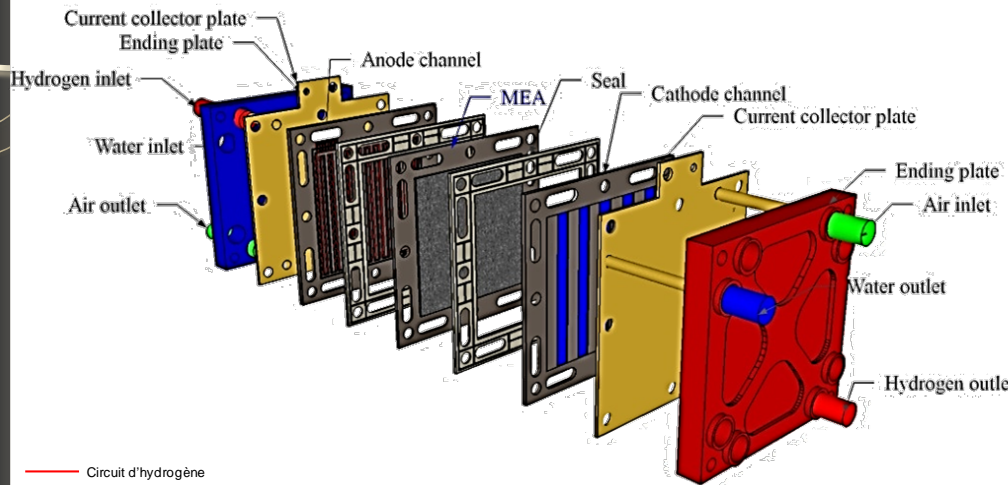

New activities at the GREEN

- Using Fuel cell as a Power Supply for Superconducting Coil

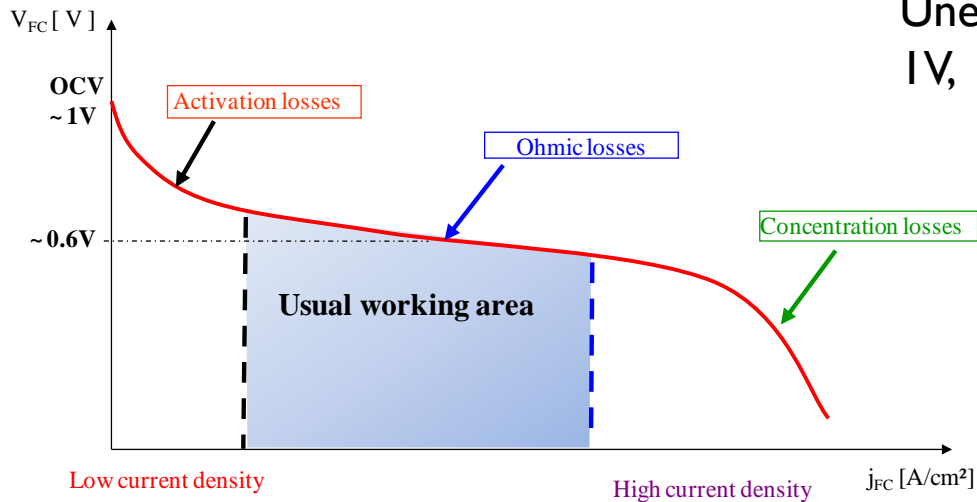

Une cellule :
1V, 50A pour 100 cm²

$$\begin{cases} I_a(t) = I_{\text{cell}}(t) - C_{\text{dLa}} \cdot \frac{d\eta_a}{dt} \\ I_c(t) = I_{\text{cell}}(t) - C_{\text{dLc}} \cdot \frac{d\eta_c}{dt} \end{cases}$$

$$V_{\text{FC}} = (E_c - \eta_c) - (E_a + \eta_a) - \eta_m$$

$$\begin{cases} \eta_c = \eta_{c,\text{act}} + \eta_{c,\text{conc}} \\ \eta_{c,\text{act}} = \frac{RT}{F} \cdot \ln\left(1 + \frac{J_c}{J_{\text{oc}}}\right) \\ \eta_{c,\text{conc}} = -\frac{RT}{F} \cdot \ln\left(1 - \frac{J_c}{J_L}\right) \end{cases}$$

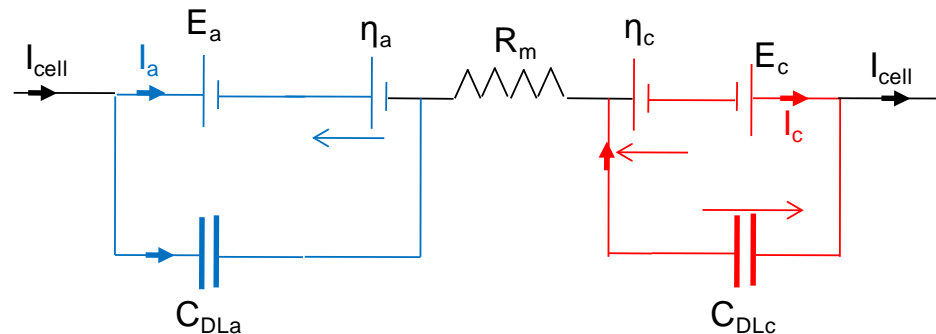

New activities at the GREEN

- Using Fuel cell as a Power Supply for Superconducting Coil

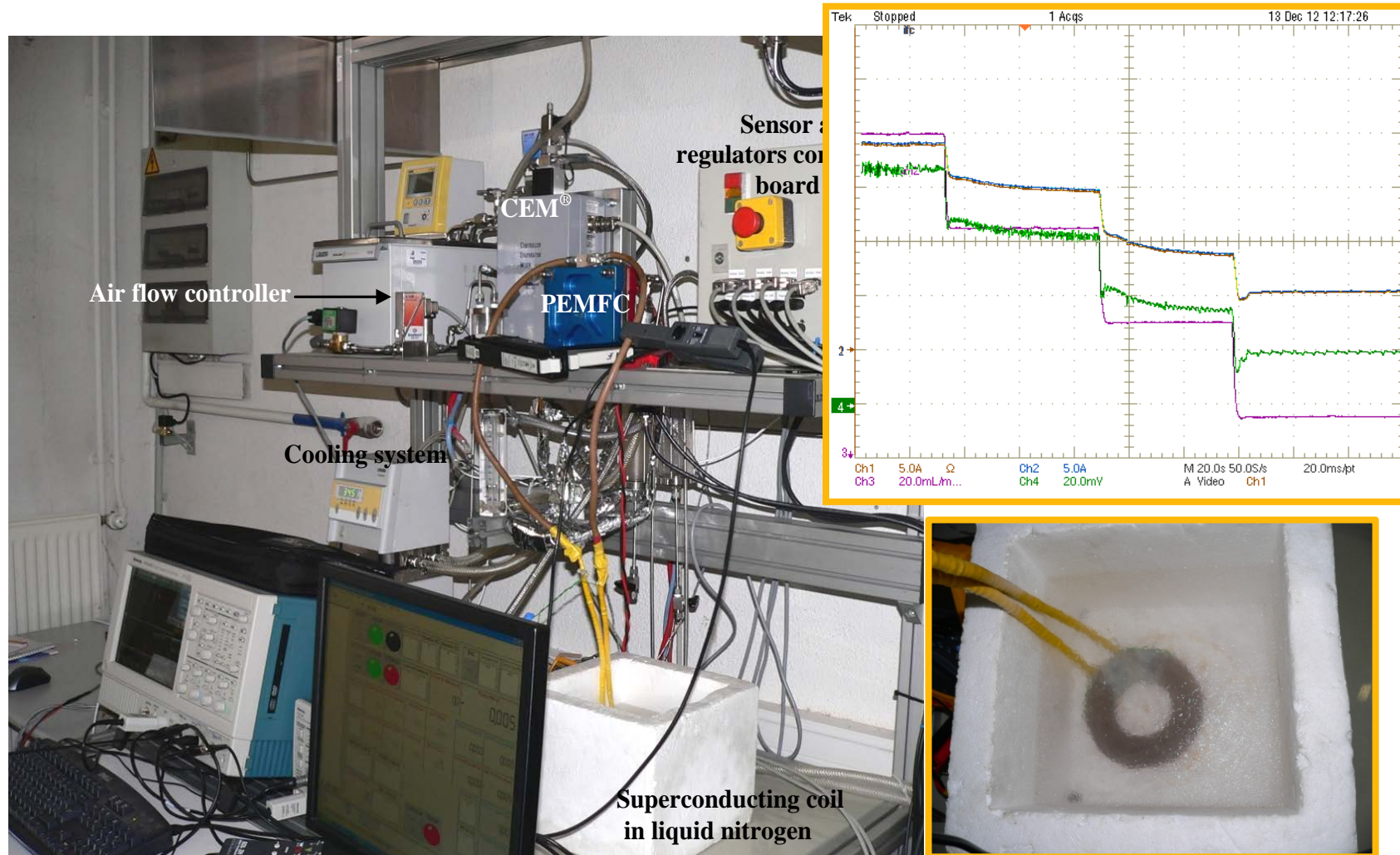

New activities at the GREEN

- A vector magnet generating up to 3 T with 3 axis orientation
 - homogeneity greater than 95% in a sphere of 10 cm diameter

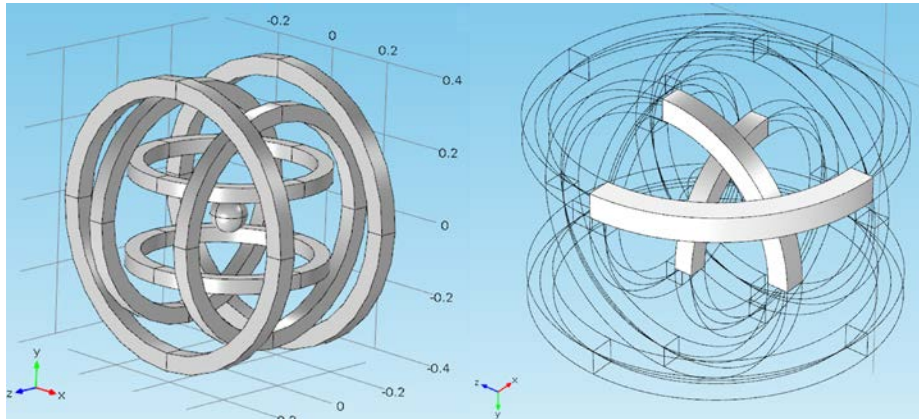

Contour de calcul
pour B_{max}

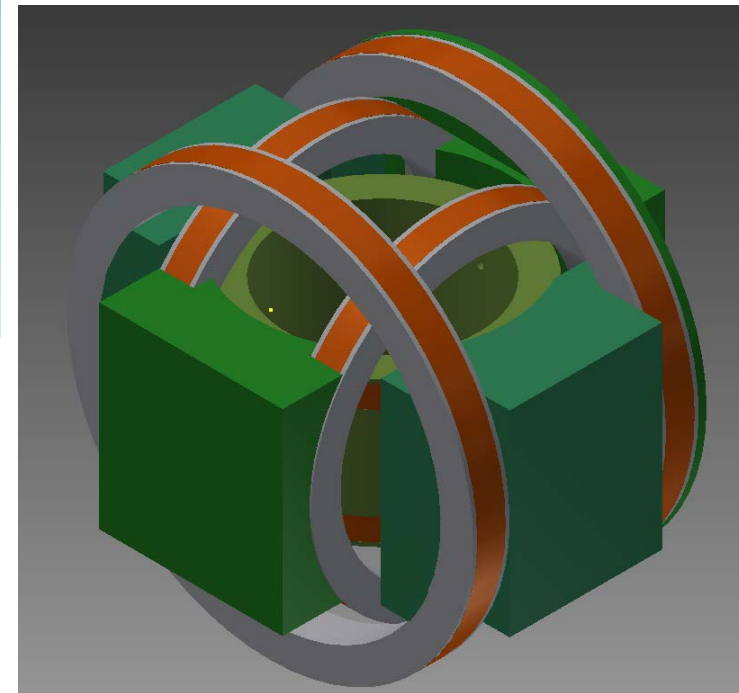
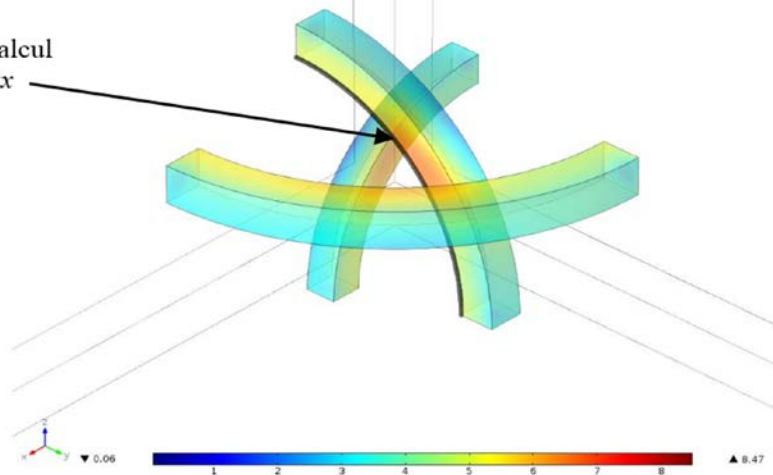

New activities at the GREEN

- Characterization bench for MgB₂ wires: 15-40 K, 1 T, 600 A

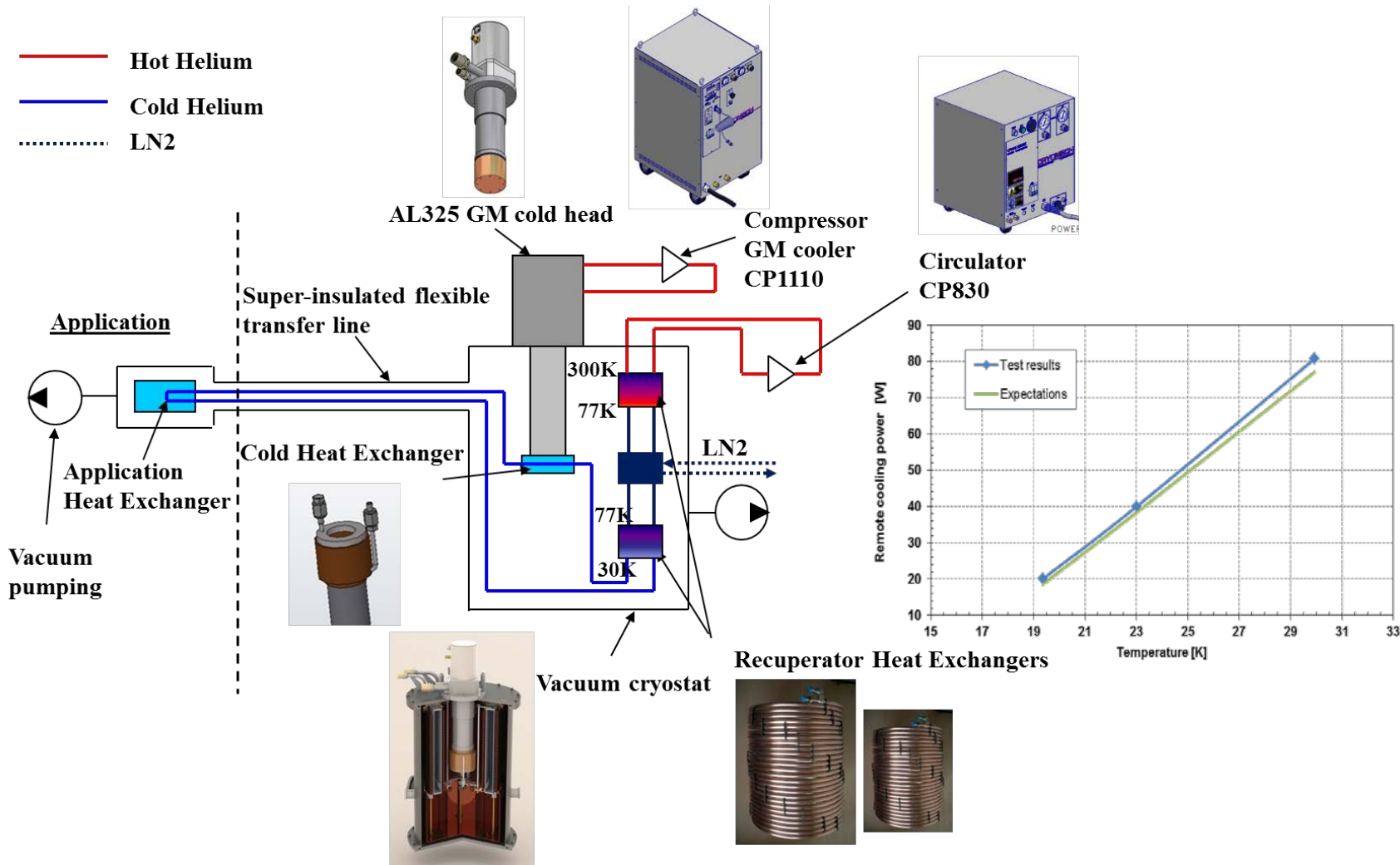

New activities at the GREEN

- Characterization bench for MgB₂ wires: 10-40 K, 1 T, 600 A

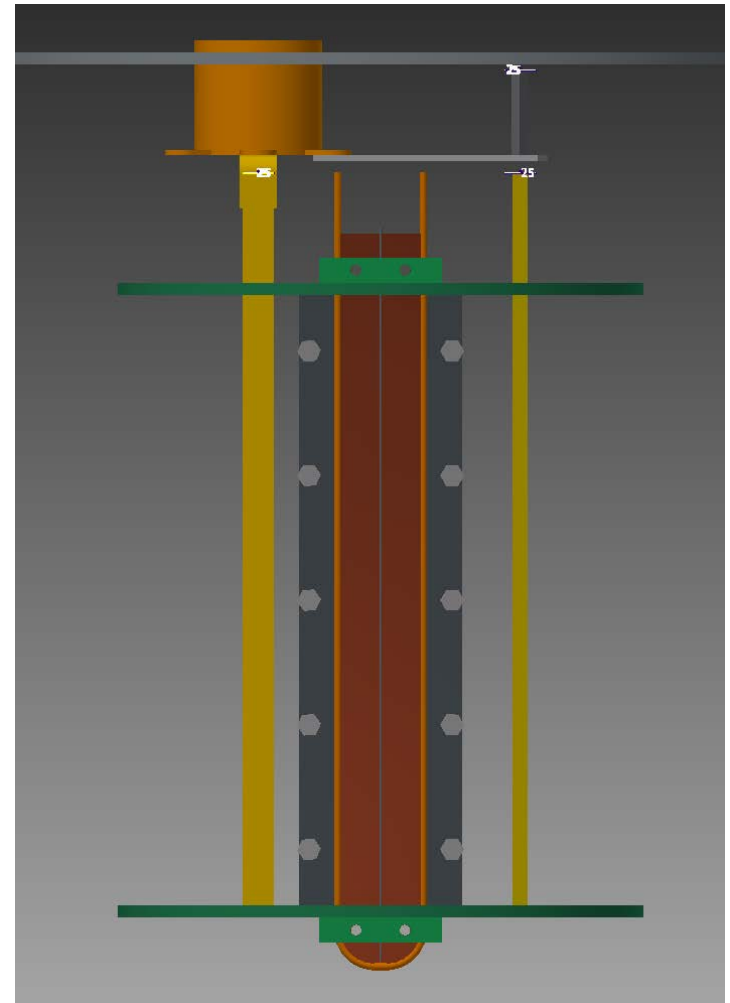
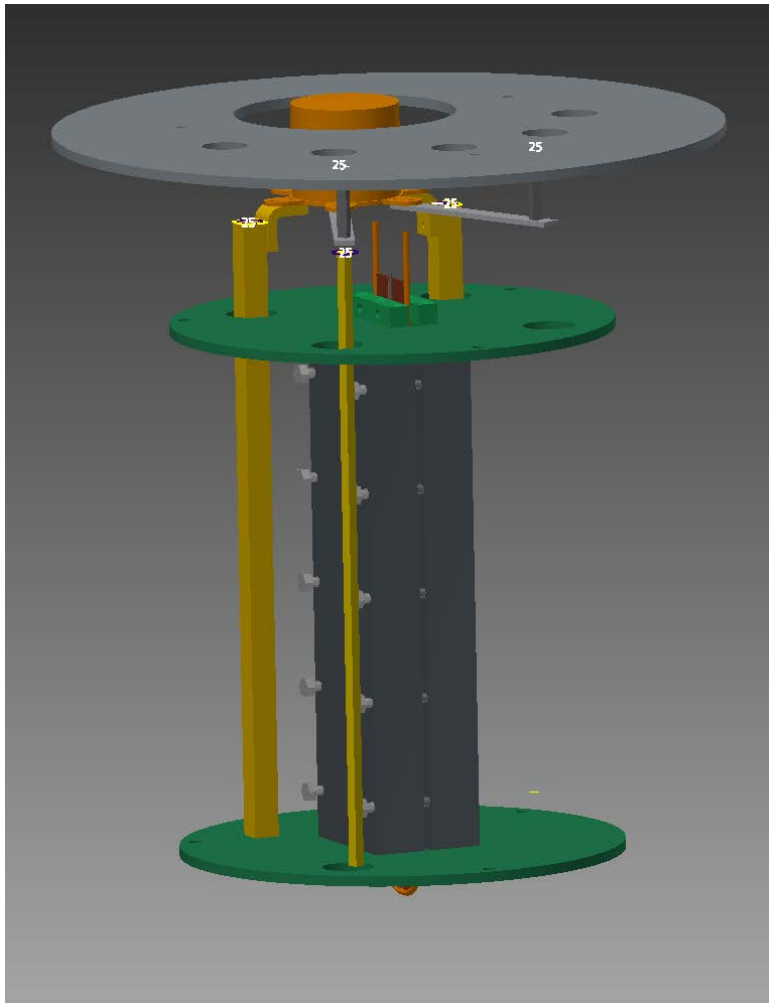

Thanks for listening!

We are looking for PhD Students...

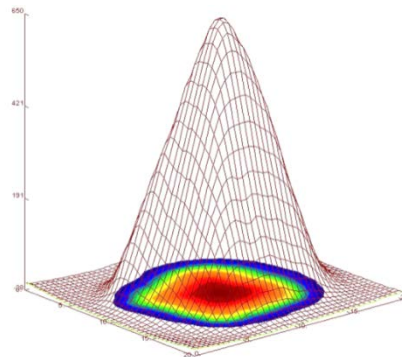

Pr B. Douine & Dr K. Berger
GREEN - Lorraine University

