

Pion pour métrologie
Qté = 8
Mat = Stub

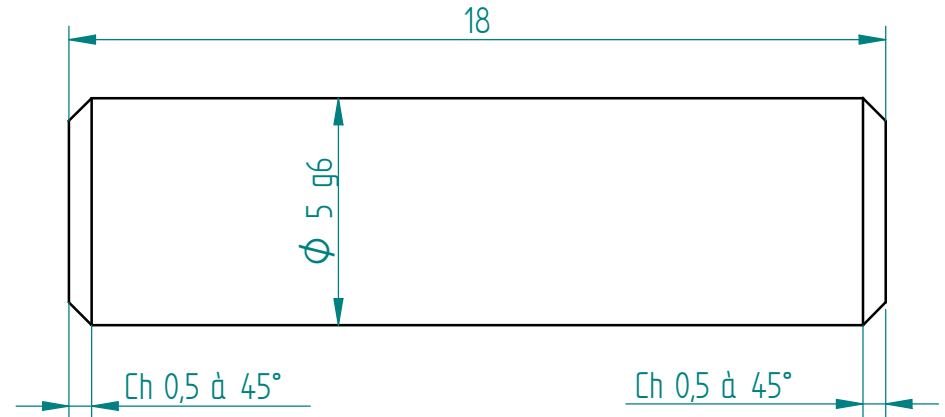

Pion assemblage des modules /Qté = 4 /Mat = Inox

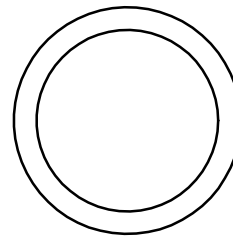
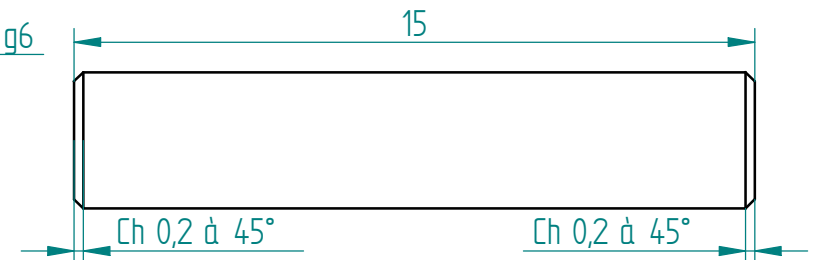
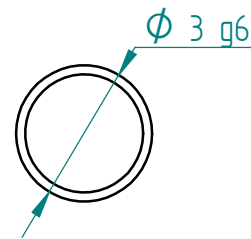

Pion assemblage des modules /Qté = 8 /Mat = Inox

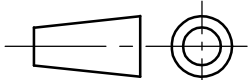
Matière: Stub & Inox		H:11 js:13	Date : 06/05/2008	Dessiné par : RIALLOT	Traitement:		
Ech : 5	Qté : 20	Titre : Pions					
		Modifié le: / /			Ide:A	Me:	Etat:R
Solid Edge		Document LPTPC/1100003			Plan: 1/1		
		C.E.A / SACLAY / IRFU / SEDI					