

# Understanding nucleus-nucleus collisions at the LHC



*Jean-Yves Ollitrault, IPHT*

*Seminar, IRFU/SPP, April 10th, 2012*

# RHIC (Brookhaven), since 2000

Au-Au collisions  
(mostly) up to  
200 GeV/nucleon pair,  
now lower energies.

Theory breakthroughs  
until 2010, just in time  
for LHC

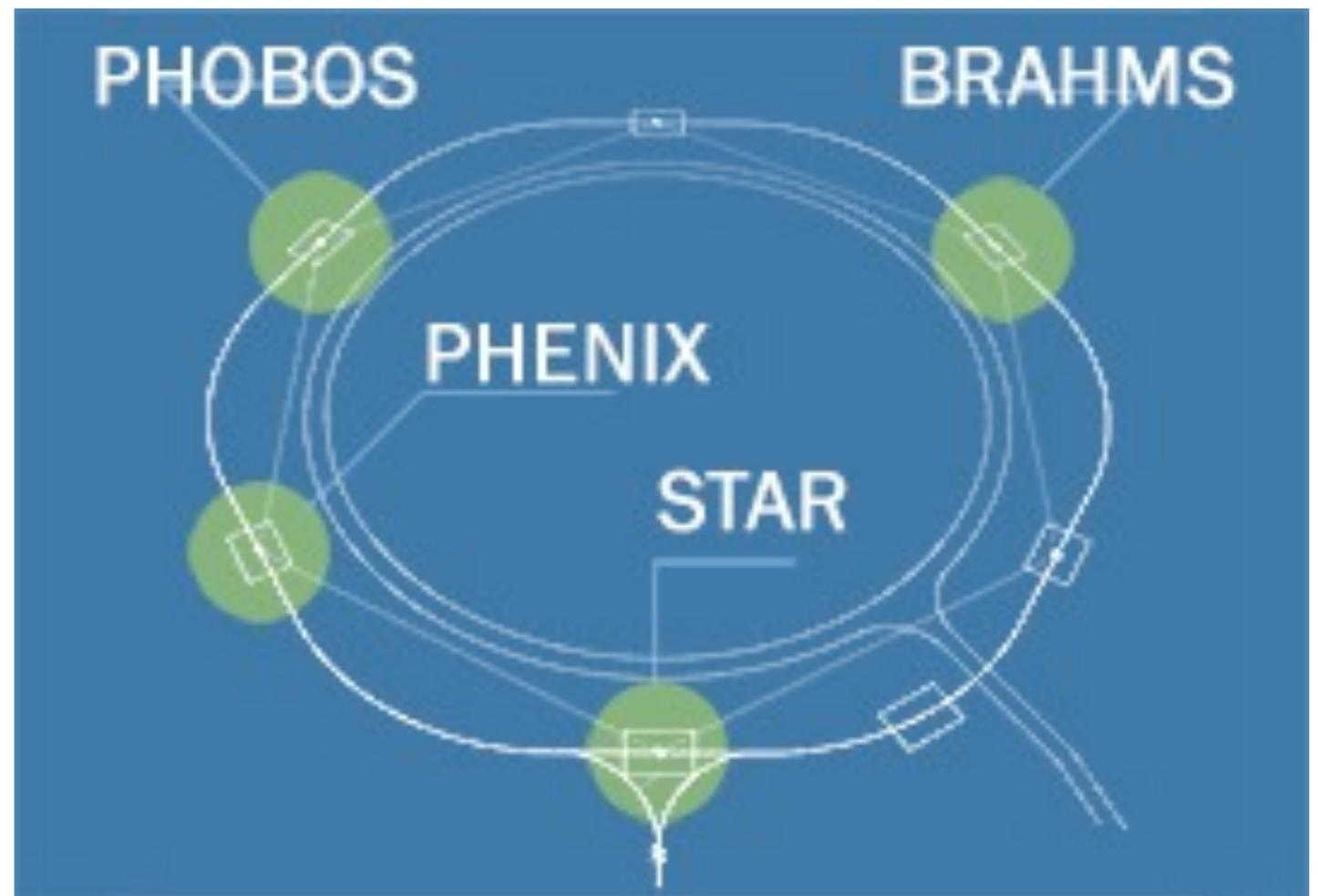

# Heavy-ions at LHC

- First heavy-ion run at 2.76 TeV/nucleon pair (Pb-Pb): Nov. 2010.
- First detailed results (ALICE, CMS, ATLAS) presented at Quark Matter 2011, May 23-28, Annecy.

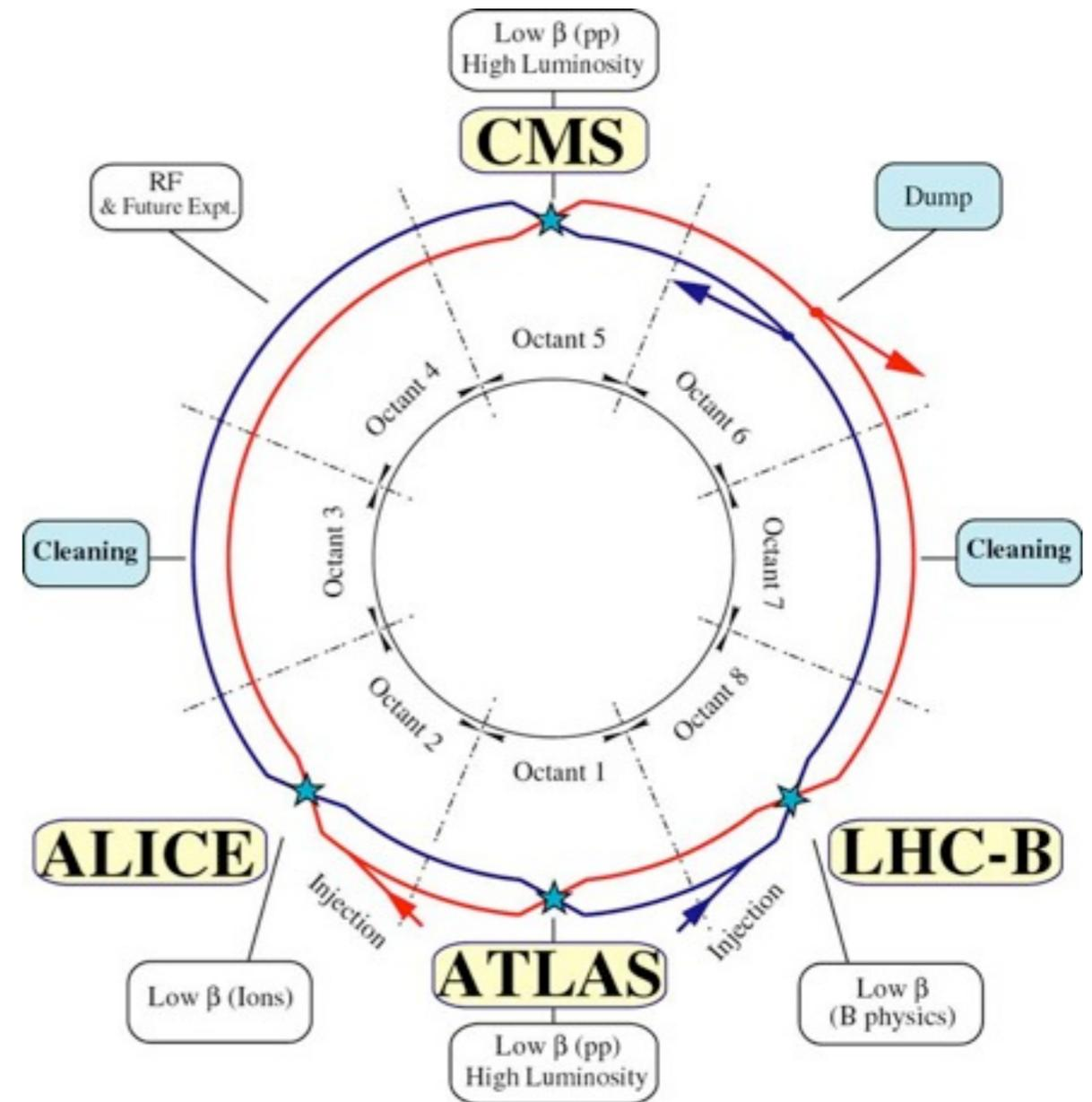

# Outline

- **Soft probes**
  - ▶ Why heavy-ion collisions are special: why we are interested in soft physics
  - ▶ pair correlations: proton-proton versus heavy-ion collisions
  - ▶ The little bang: the old picture (2000) and the new picture (2010): **qualitative ideas**
  - ▶ **Quantitative** prediction versus new LHC data (2011)
- **Hard probes**
  - ▶ from p-p to Pb-Pb collisions: weakly-interacting versus strongly-interacting probes
  - ▶ Jet quenching : from leading particles to fully-reconstructed jets
- **Conclusions**

# Space-time picture of an ultrarelativistic heavy-ion collision

*Thanks to the strong Lorentz contraction, clear separation of time scales – and theory tasks*

*cartoon using the Monte-Carlo transport code UrQMD*

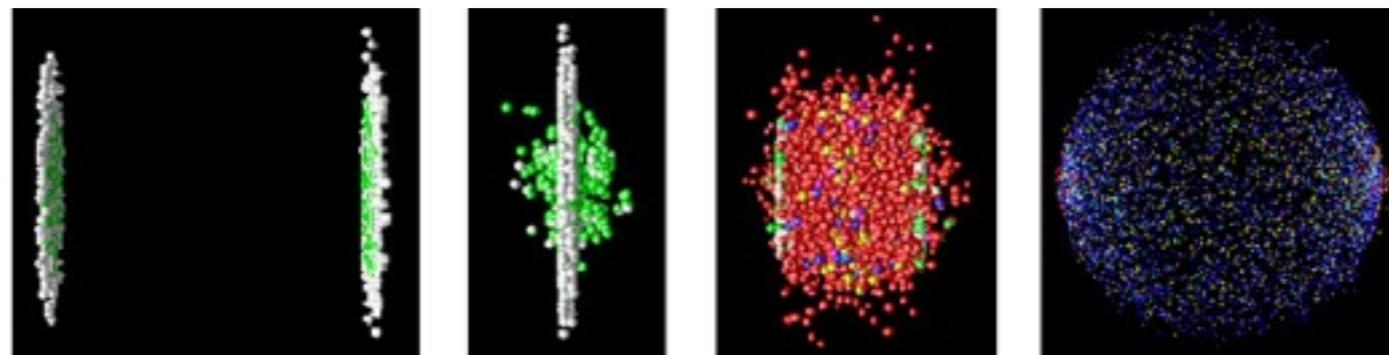

Initial conditions

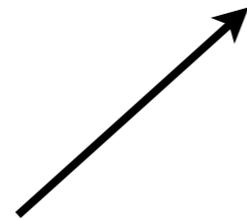

Hadronization and freeze-out

**Expansion**

# Two-particle correlations at RHIC

$\approx$  number of particle pairs versus *relative* azimuthal angle  $\Delta\Phi$  and rapidity  $\Delta\eta$

*G. Stephans (PHOBOS), talk at QM'09*

p+p@200GeV

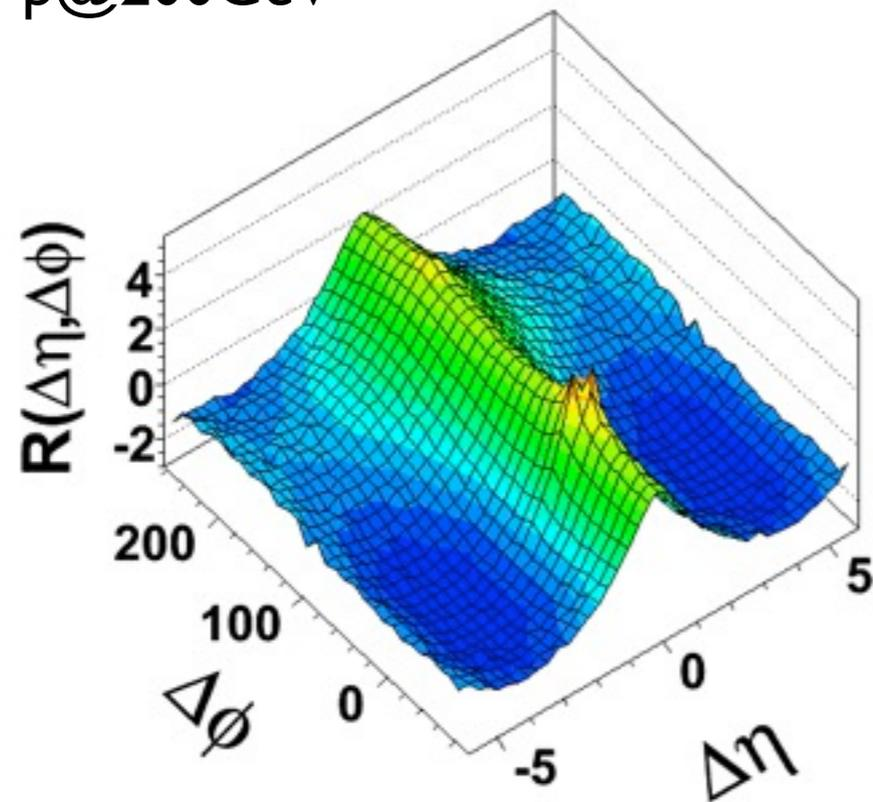

Central Au+Au@200GeV

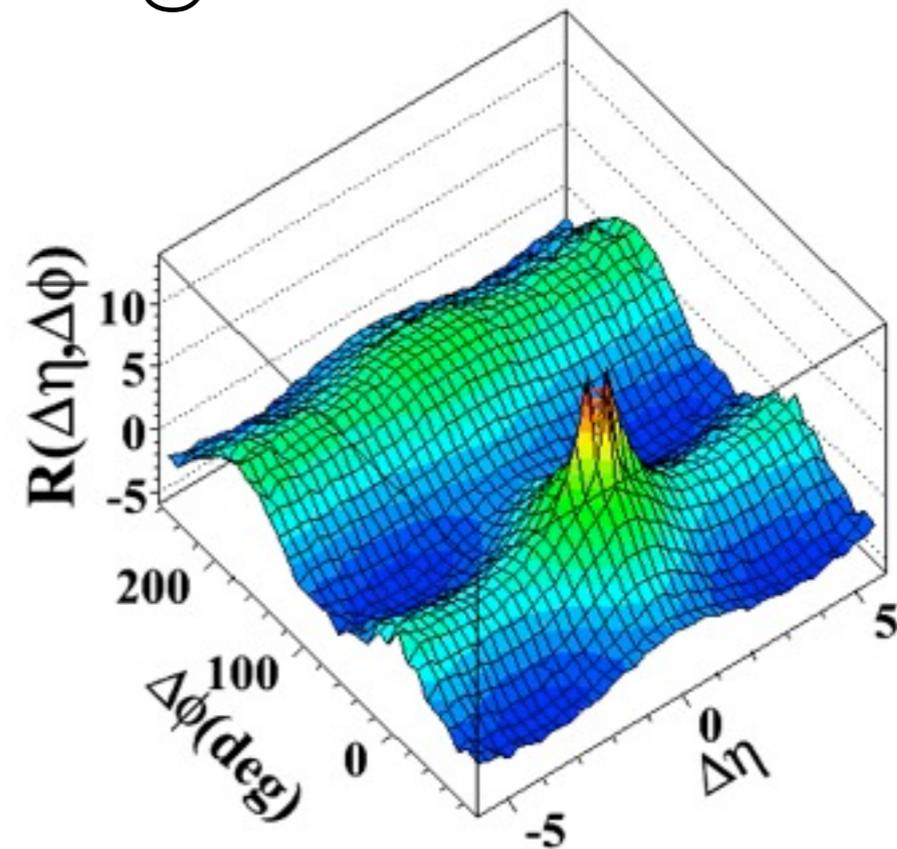

- ✓ short range in rapidity
- ✓ little azimuthal structure

- ✓ long range in rapidity
- ✓ specific azimuthal structure

# Two-particle correlations at RHIC

$\approx$  number of particle pairs versus *relative* azimuthal angle  $\Delta\Phi$  and rapidity  $\Delta\eta$

*G. Stephans (PHOBOS), talk at QM'09*

p+p@200GeV

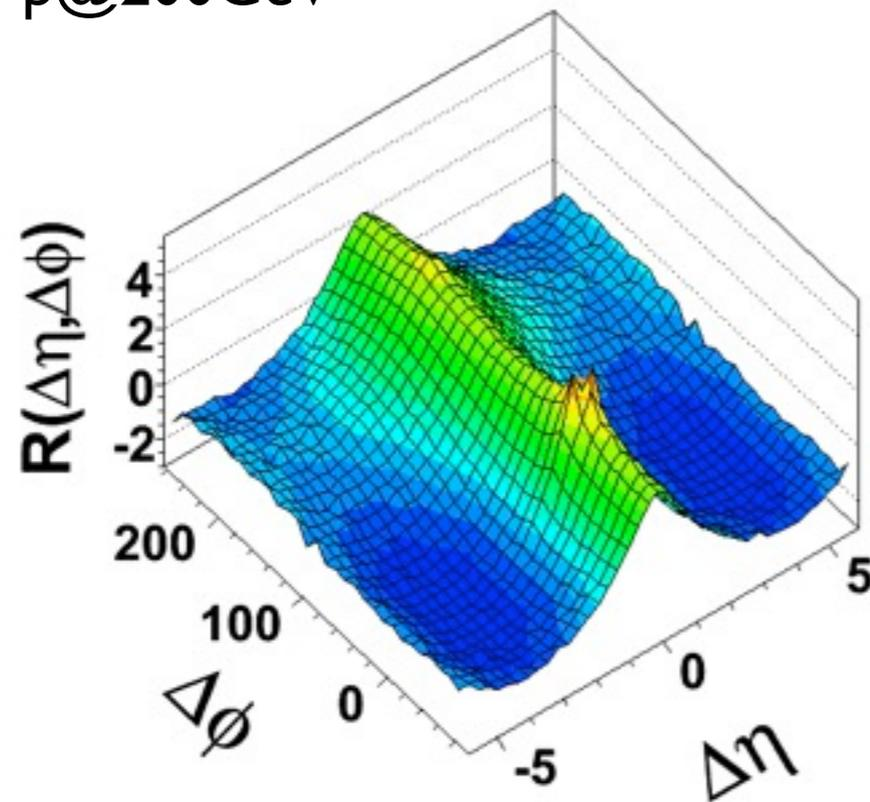

- ✓ short range in rapidity
- ✓ little azimuthal structure

Central Au+Au@200GeV

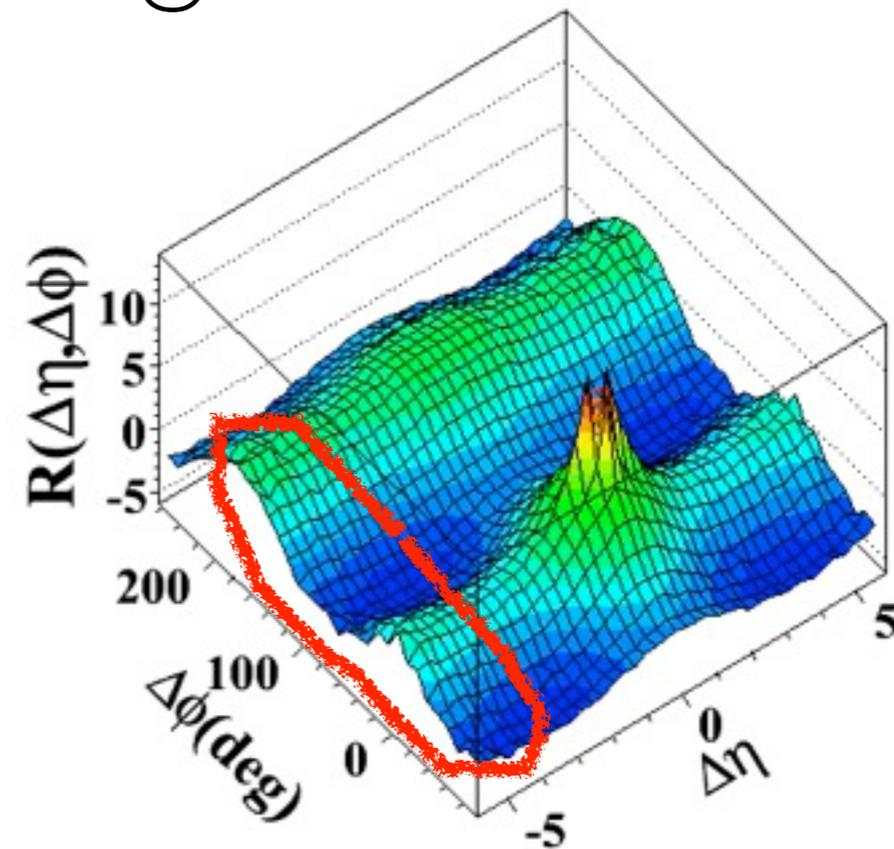

- ✓ long range in rapidity
- ✓ specific azimuthal structure

# Correlations in pp @ LHC

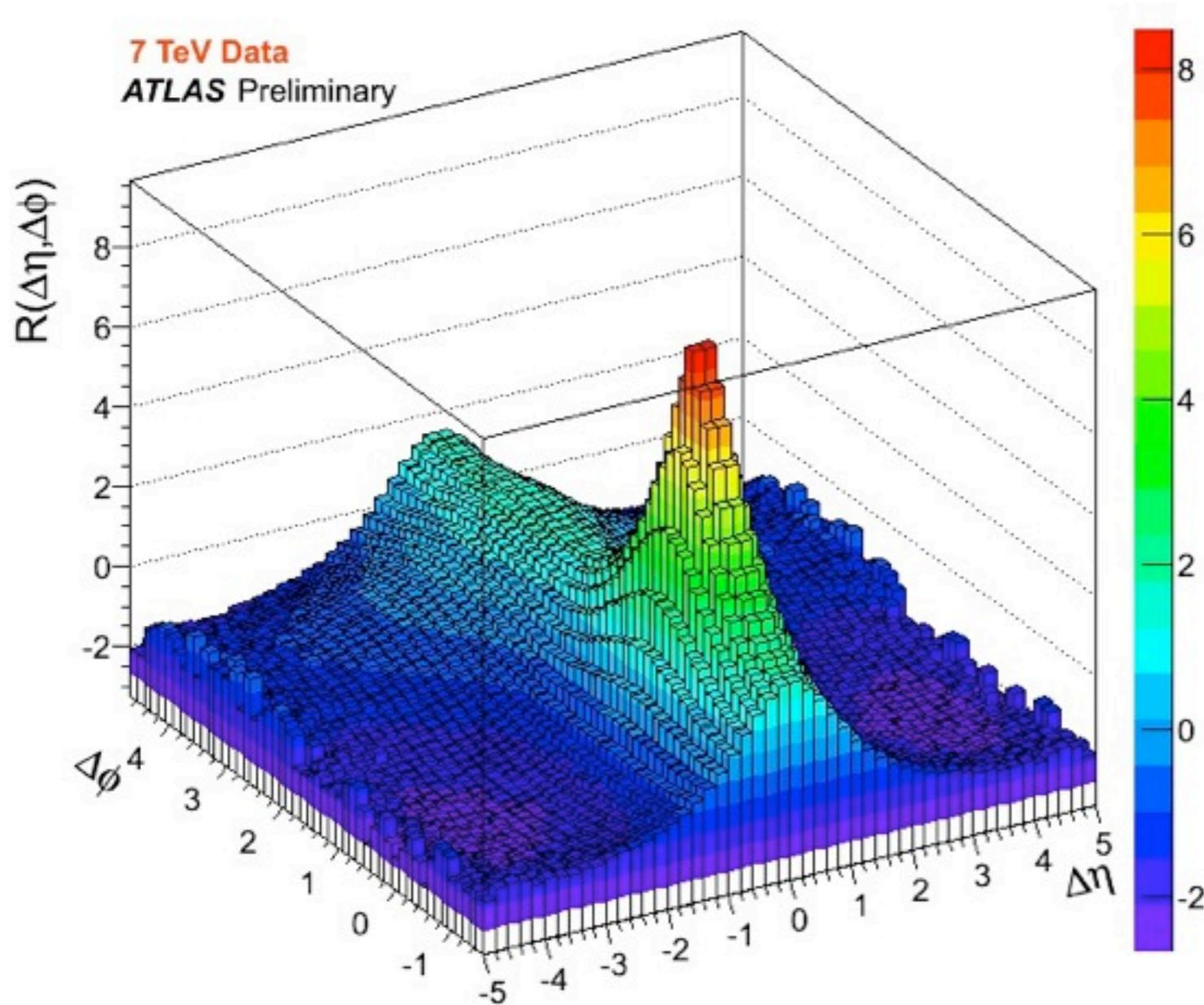

proton proton collisions  
at LHC:  
again, all correlations are  
at small  $\Delta\eta$   
qualitatively reproduced  
by models (Pythia)

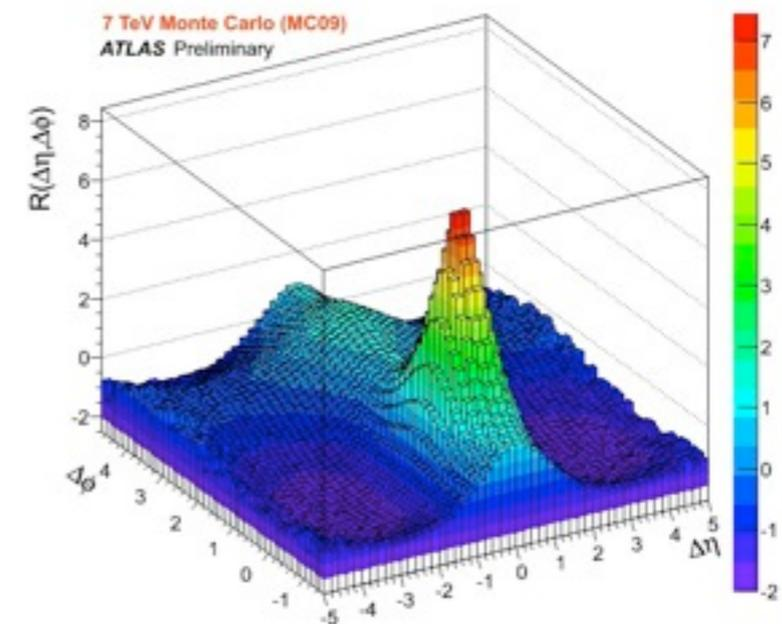

# Correlations in Pb-Pb @ LHC

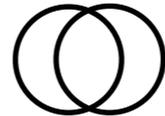
(semicentral) 

CMS Preliminary  
PbPb  $\sqrt{s_{NN}} = 2.76$  TeV

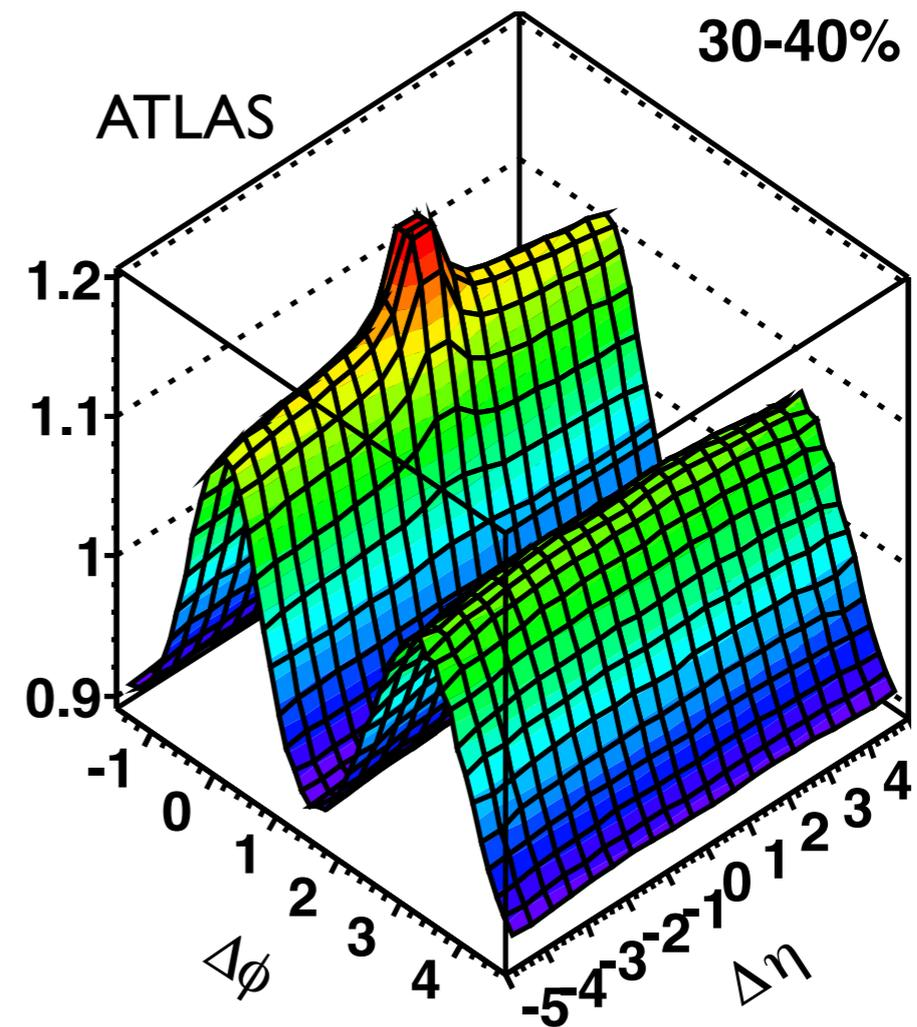
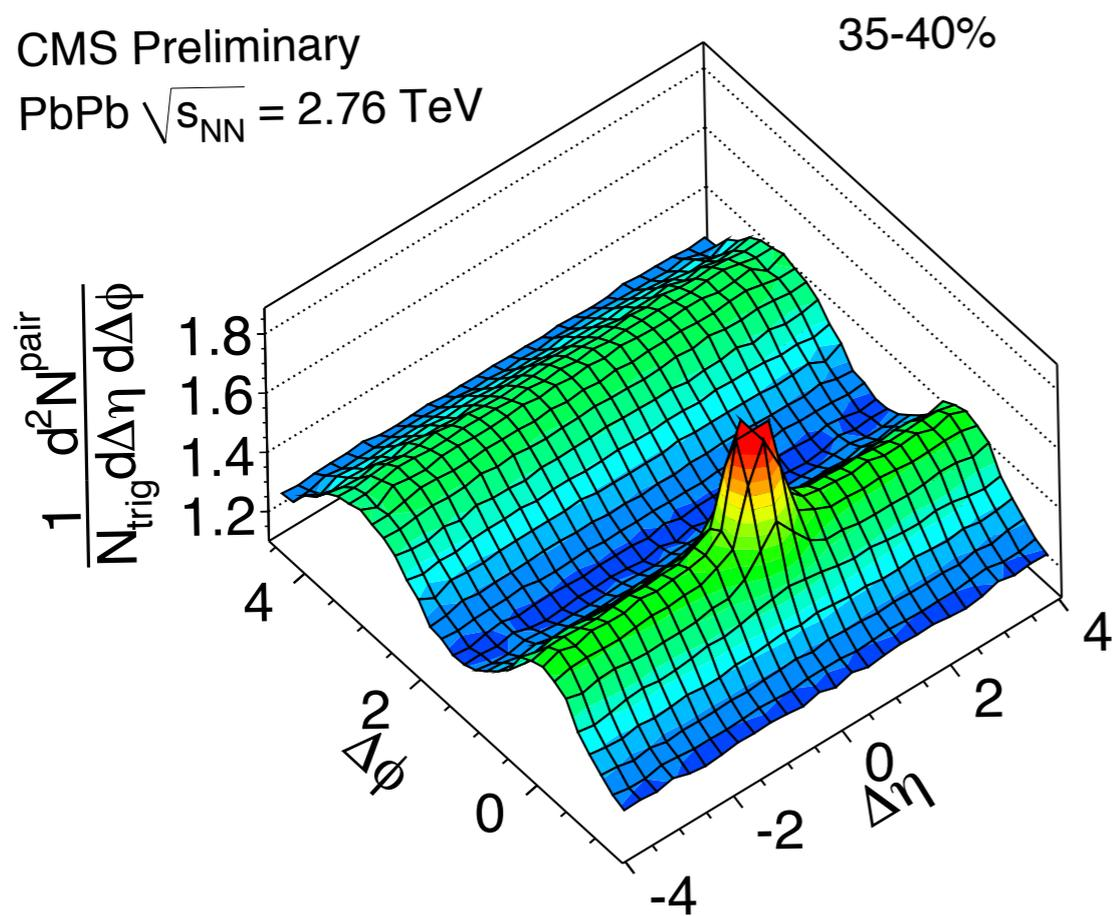

## Additional correlation, independent of $\Delta\eta$

not quite apples-to-apples: restricted  $p_t$  interval here, [2,3] GeV for ATLAS and [2,4][4,6] CMS

# Collective flow: the old picture

(RHIC, 2000)

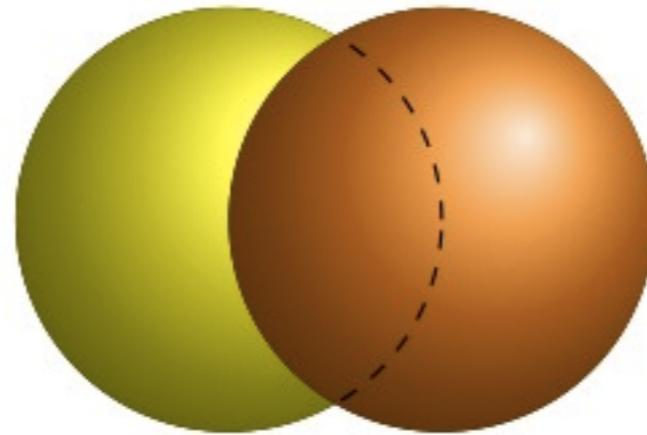

# Collective flow: the old picture

(RHIC, 2000)

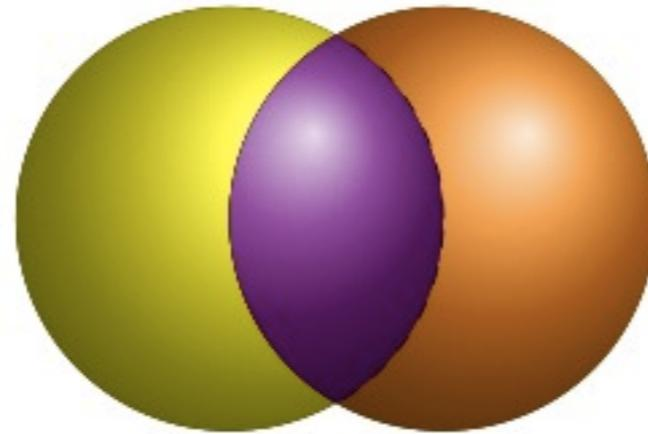

# Collective flow: the old picture

(RHIC, 2000)



# Collective flow: the old picture

(RHIC, 2000)

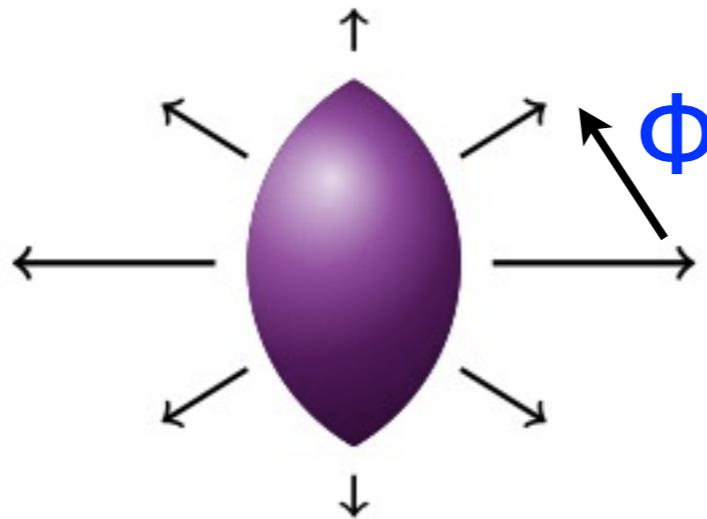

The system thermalizes and expands like a **fluid**

# Collective flow: the old picture

(RHIC, 2000)

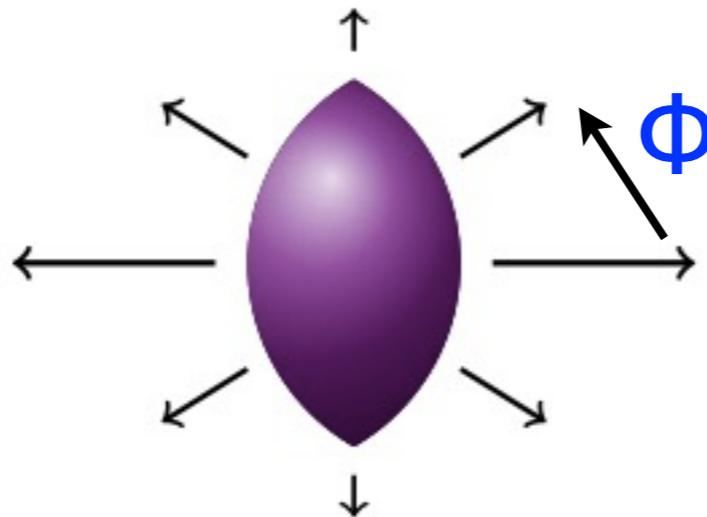

The system thermalizes and expands like a **fluid**

Particles are emitted **independently** in each event, with a  $\phi$ -dependent distribution  $dN/d\phi = (N/2\pi)[1+2v_2 \cos(2\phi)]$   
 $v_2$ , elliptic flow, is a day 1 observable at RHIC and LHC  
it depends weakly on rapidity

*STAR nucl-ex/0009011, 458 citations*

*ALICE arXiv:1011.3914, 174 citations*

# Independent particles explain pair correlations

$$v_2 = \langle e^{2i\phi} \rangle \quad (\text{reference direction } \phi=0 \text{ changes event by event!})$$

$$\langle e^{2i\Delta\phi} \rangle = \langle e^{2i(\phi_1 - \phi_2)} \rangle = \langle e^{2i\phi_1} e^{-2i\phi_2} \rangle$$

$$= \langle e^{2i\phi_1} \rangle \langle e^{-2i\phi_2} \rangle = (v_2)^2$$

$$dN_{\text{pair}}/d\Delta\phi = (N_{\text{pair}}/2\pi) [1 + 2(v_2)^2 \cos(2\Delta\phi)]$$

# Is $v_2$ all we see at large $\Delta\eta$ ?

Au+Au 0%-10%

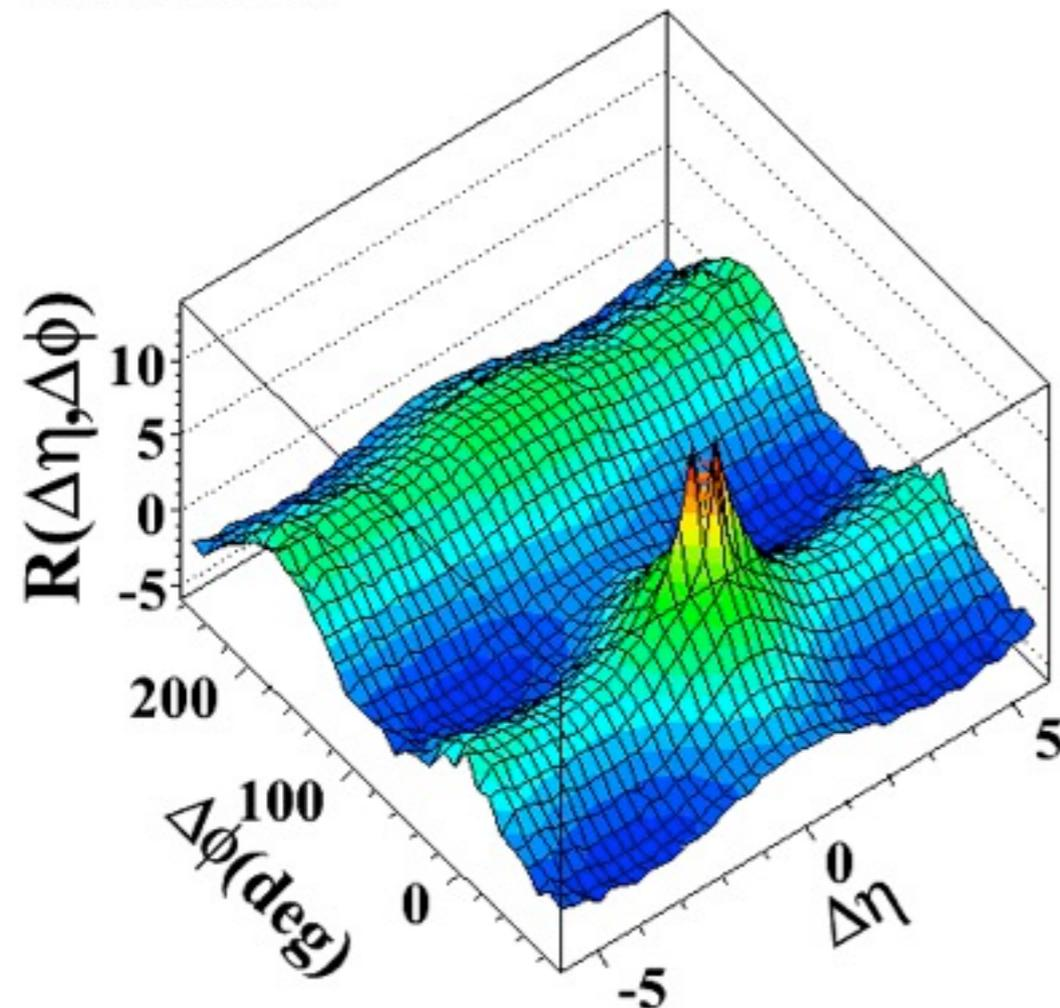

Correlation at large  $\Delta\eta$  clearly dominated by a  $\cos(2\Delta\phi)$  term **but** the peak at  $\Delta\phi=0$  is **narrower** than that at  $\Delta\phi=\pi$  this **narrow, near-side ridge** and this **broad away-side structure** have puzzled heavy ion physicists from 2005 to 2010.

# Fluctuations

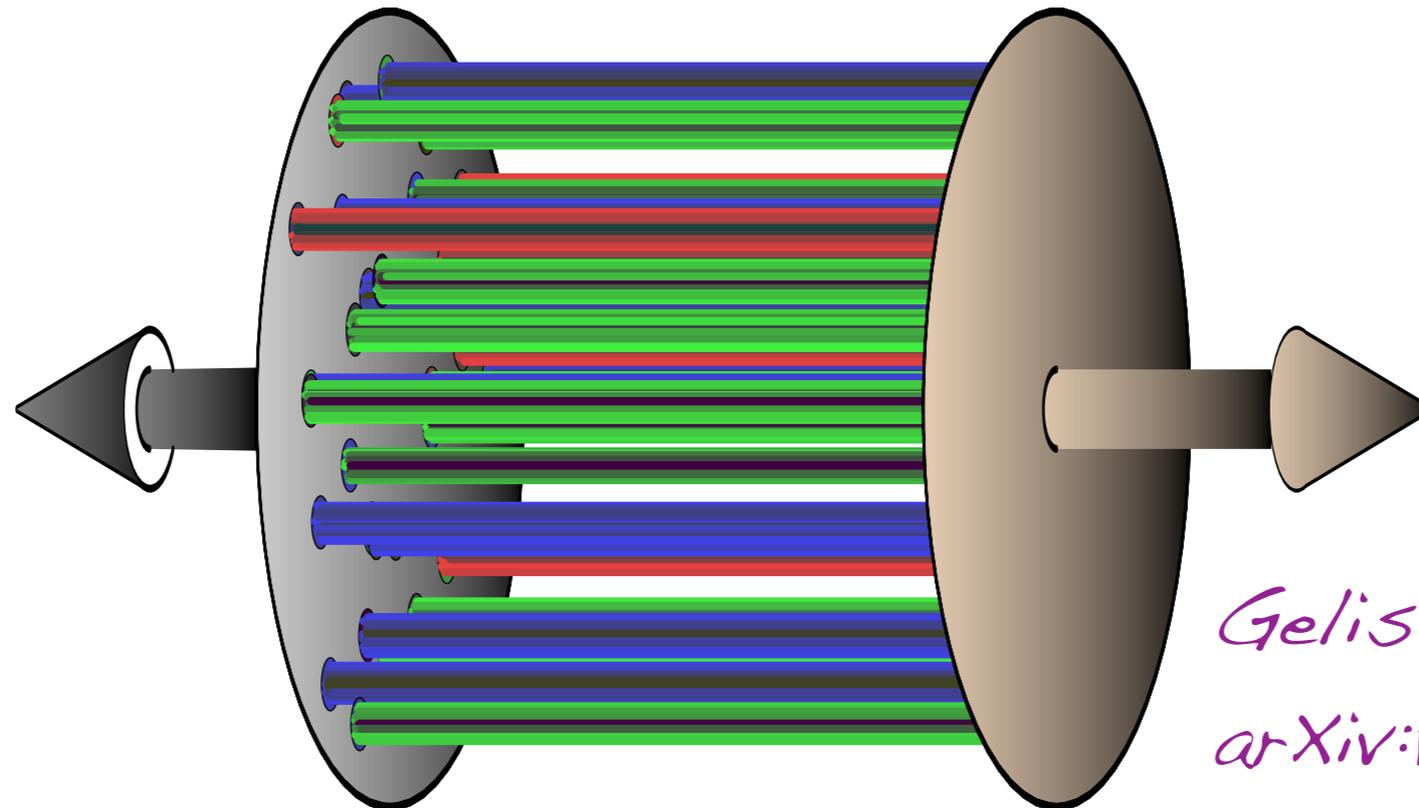

*Gelis et al,  
arXiv:1102.0333*

Each nucleus is made of a 208 nucleons.  
The collision takes a snapshot of the nuclear wavefunction:  
initial density is **lumpy in the transverse plane**, but  
**approximately independent of rapidity**

# Fluctuations + flow

The initial state is no longer symmetric under  $\phi \rightarrow -\phi$  and  $\phi \rightarrow \phi + \pi$

The final  $\phi$  distribution in a single event is arbitrary:

$$dN/d\phi = (N/2\pi) [1 + 2 \sum_n v_n \cos(n(\phi - \psi_n))]$$

both even and odd harmonics, each with its own direction  $\psi_n$

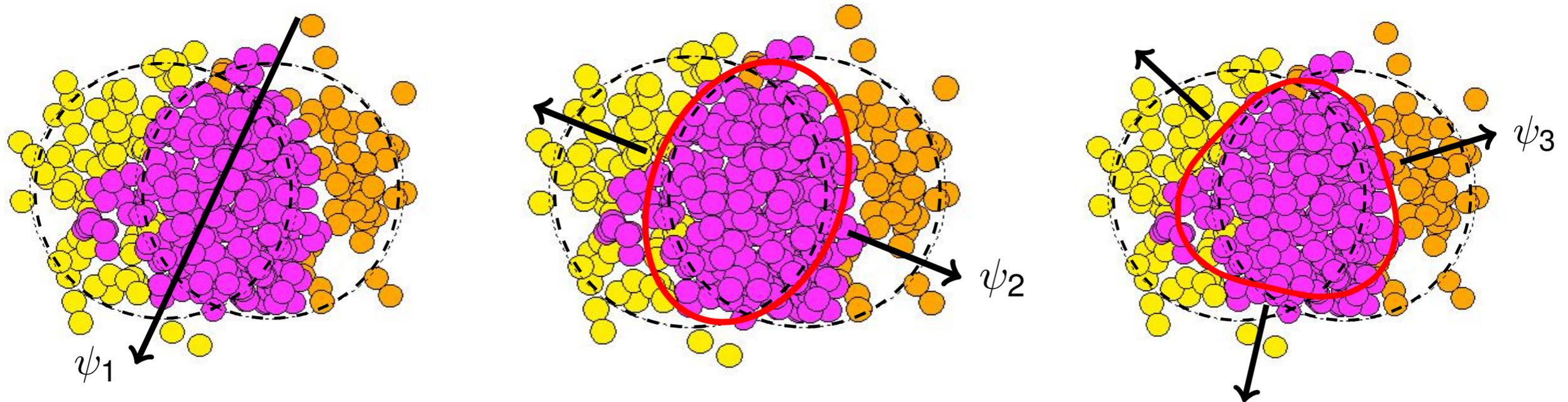

# From flow to correlations: the new picture (2010)

$$v_n = \langle e^{in(\phi - \Psi_n)} \rangle \quad (v_n \text{ and reference directions } \Psi_n \text{ change event by event!})$$

$$\langle e^{in\Delta\phi} \rangle = \langle e^{in(\phi_1 - \Psi_n)} e^{-in(\phi_2 - \Psi_n)} \rangle$$

$$= \langle e^{in(\phi_1 - \Psi_n)} \rangle \langle e^{-in(\phi_2 - \Psi_n)} \rangle = (v_n)^2$$

$$dN_{\text{pair}}/d\Delta\phi = (N_{\text{pair}}/2\pi) [1 + 2\sum_n (v_n)^2 \cos(n\Delta\phi)]$$

this explains why near-side narrower than away-side!

independent particle emission explains data up to  $p_t \approx 5 \text{ GeV}$

*Alver Roland, "triangular flow" arXiv:1003.0194*

*Luzum arXiv:1011.5773, ALICE arXiv:1109.2501*

# Quantitative prediction for low $p_t$ physics

- Goal: compute the **single** particle distribution (in particular,  $\Phi$  distribution) in an event
- Model for initial state, **including fluctuations**  
(bottleneck: the only models available on the market are very crude)
- Evolve through **relativistic viscous hydrodynamics**
- Fluid eventually freezes into particles: compute spectra, elliptic flow, etc.
- We now have data from ALICE, CMS, ATLAS

# Why hydrodynamics?

- The only theory describing the space-time history of a **large**, strongly-interacting system
- Can be formulated as a systematic gradient expansion = power expansion in  $l/R$ , where  $R$ =nuclear radius

$$\partial_{\mu}((\varepsilon+P)u^{\mu}u^{\nu}-Pg^{\mu\nu}) + \eta \partial_{\mu}\partial_{\rho}\dots + \partial_{\mu}\partial_{\rho}\partial_{\sigma}\dots = 0$$

**Infinite** system:  
Ideal hydrodynamics

shear viscosity

$l/R$  corrections  
viscous hydrodynamics  
relativistic Navier-Stokes

$l/R^2$  corrections  
Israel-Stewart theories

*Is a nucleus large enough? is the viscosity small enough for hydro?*

# (some) Hydro groups

- *Luzum & Romatschke, arXiv:0901.4588*
- *Shen, Heinz, Huovinen & Song arXiv:1105.3226*
- *Bozek, Chojnacki, Florkowski & Tomasik, arXiv:1007.2294*
- *Schenke, Jeon & Gale, arXiv:1009.3244*
- *Petersen et al, arXiv:0806.1695*
- *Takahashi et al, arXiv:0902.4870*
- *Hirano, Monnai, arXiv:0903.4436*
- *Chaudhuri, arXiv:0910.0979*
- *Holopainen et al, arXiv:1007.0368*
- *Werner et al, arXiv:1004.0805*

# Lattice QCD enters the precision era

Equation of state of hot QCD (*input of hydrodynamics*) now calculated with dynamical quarks and physical quark masses!

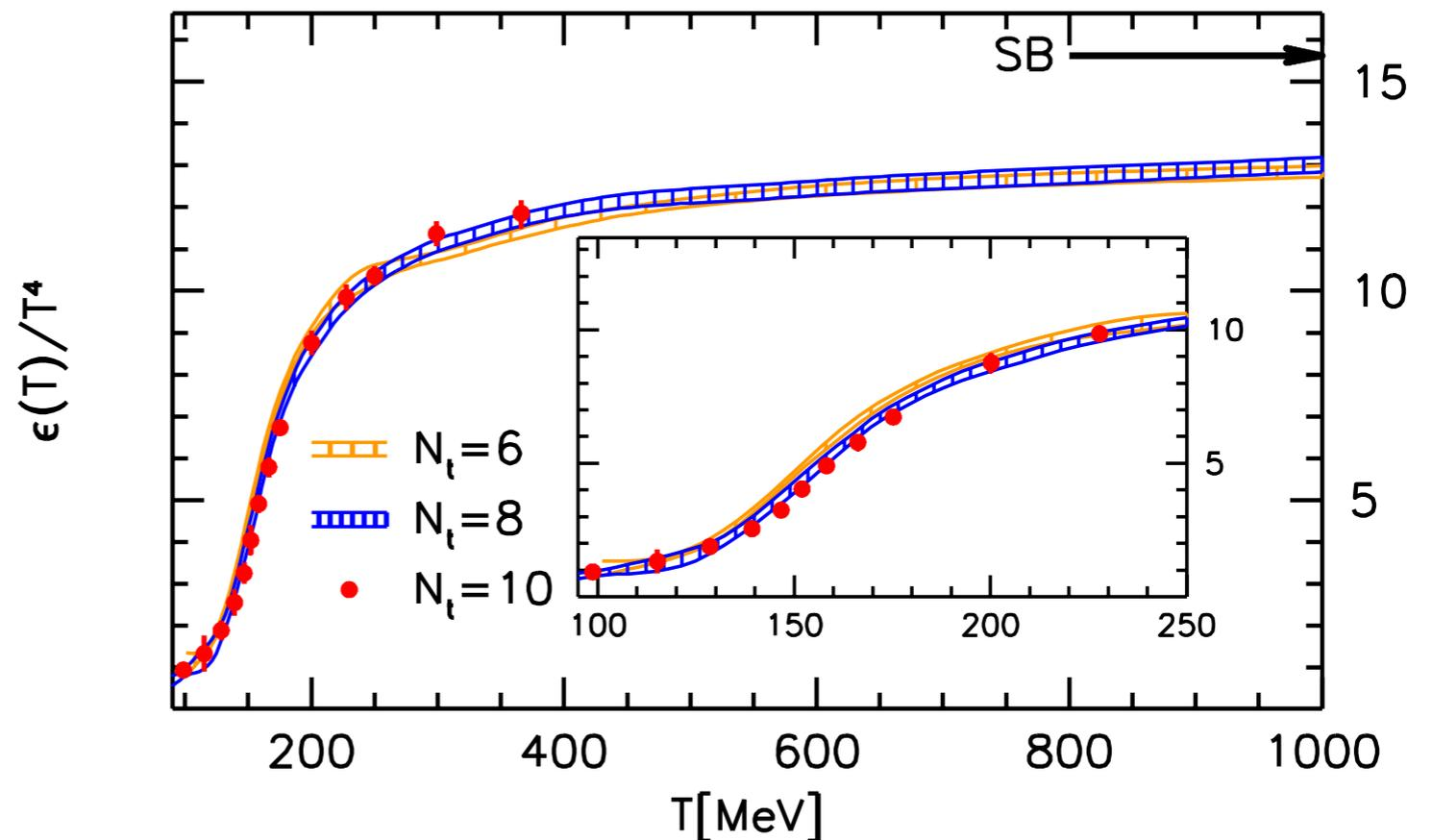

*Borsanyi et al, arXiv:1007.2580*

*However, the viscosity  $\eta$  is not yet calculated: free parameter in hydro*

# Hydro prediction versus 1<sup>st</sup> LHC data

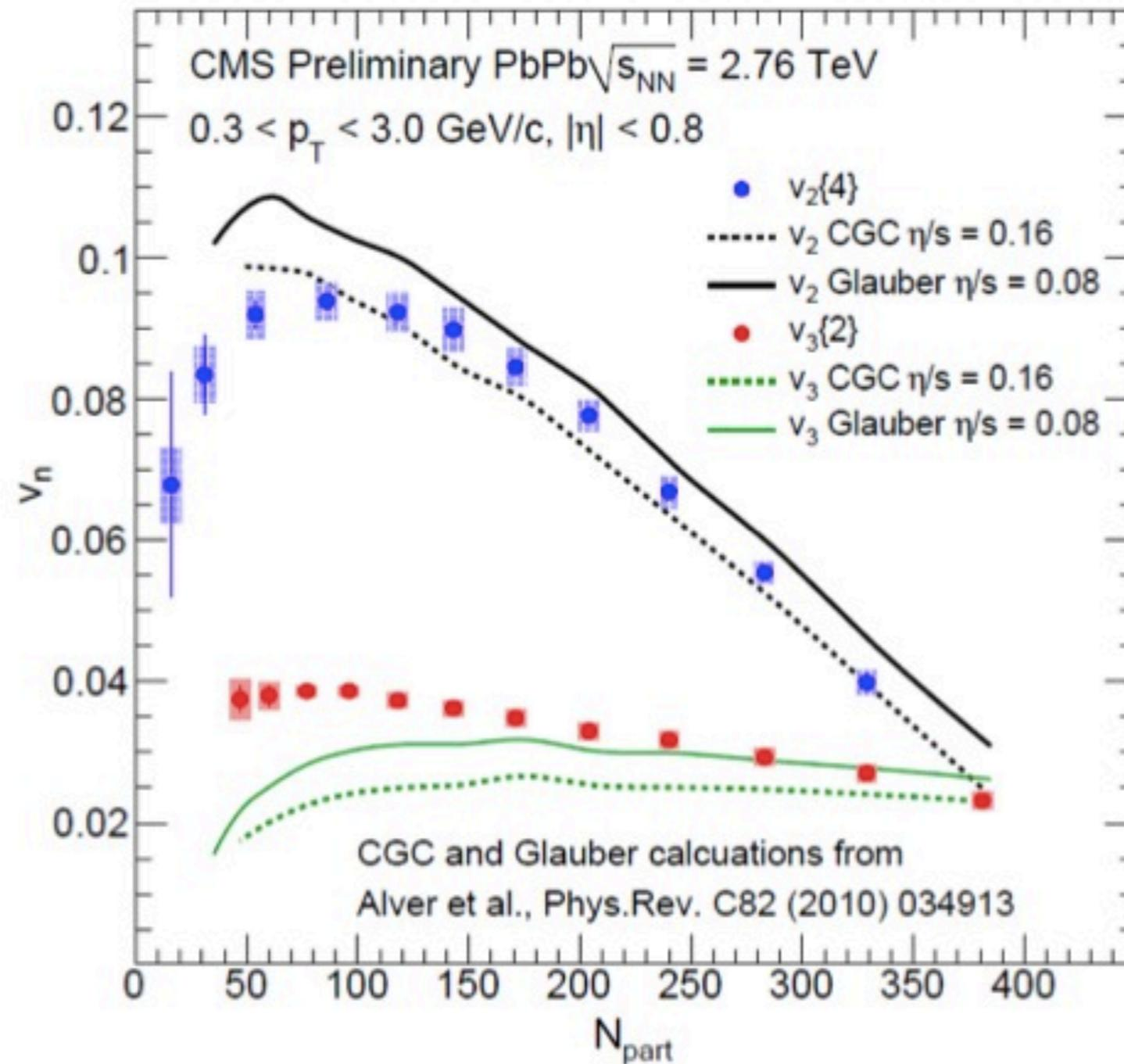

*Julia Velkowska,  
 plenary talk  
 at QM2011*

*Luzum,  
 arXiv:1011.5173*

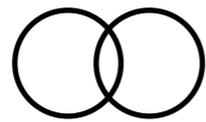

peripheral

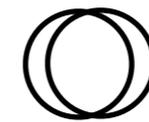

central

# More details: dependence on particle momentum

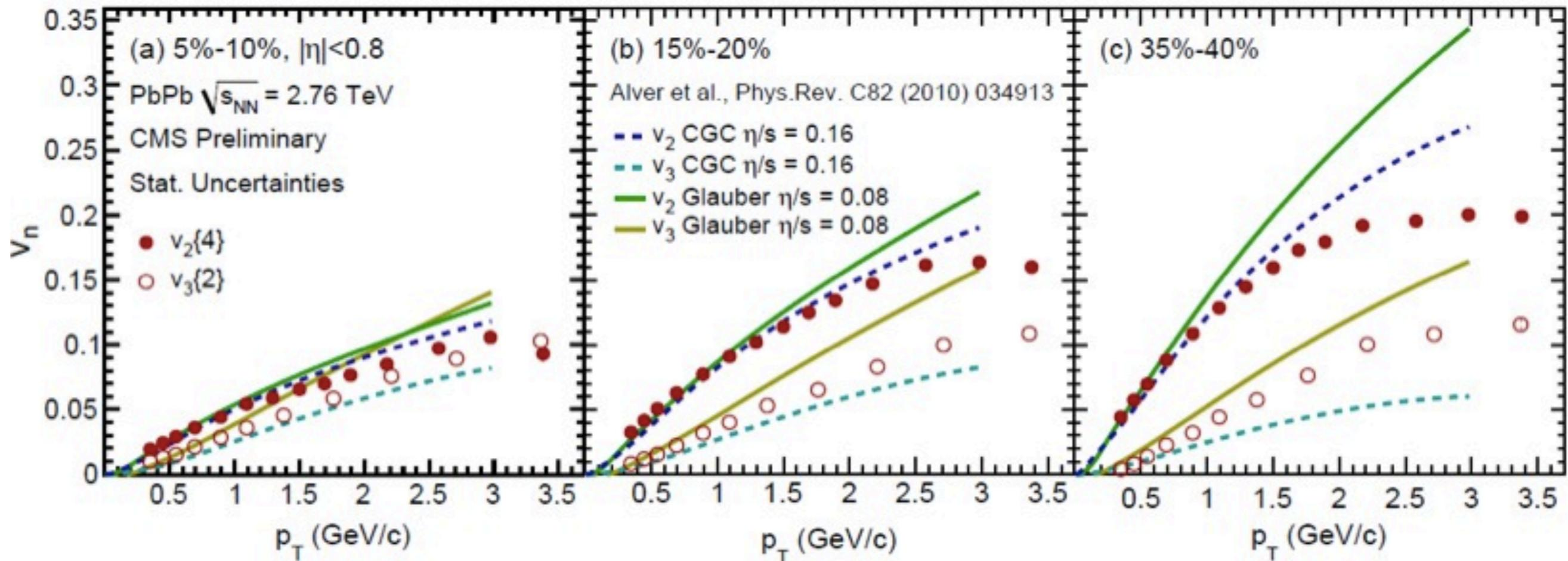

*Julia Velkowska, plenary talk at QM2011*

Hydrodynamics captures the magnitude, the centrality dependence and the momentum dependence of both elliptic and triangular flow.

# First measurement of $v_1$ at LHC + first viscous hydro calculation of $v_1$

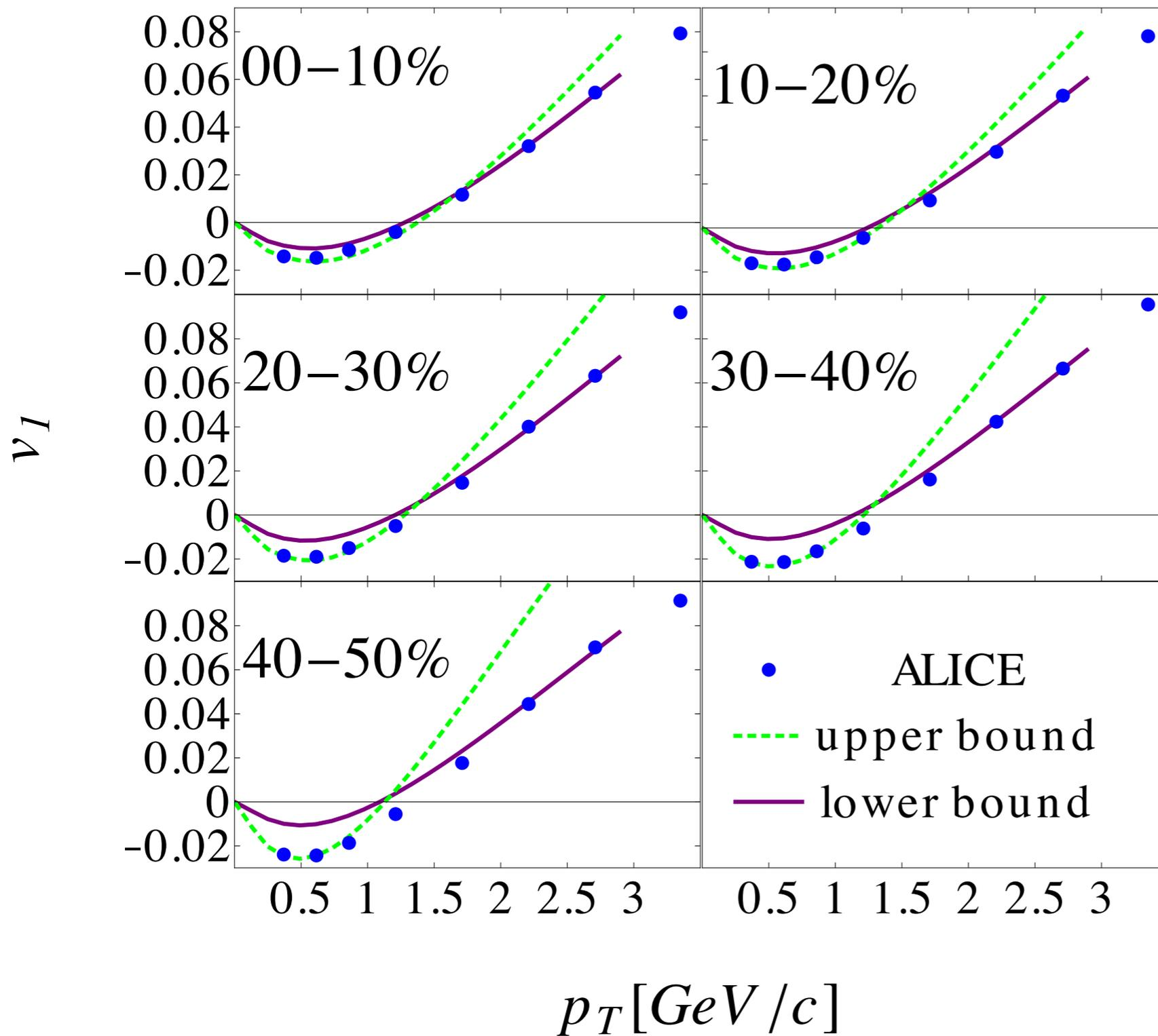

*Retinskaya, Luzum,  
JYO, arXiv:1203.0931  
(using ALICE data)*

*ATLAS,  
arXiv:1203.3087*

# Hard probes : testing pQCD in Pb-Pb collisions

*(from Lamia Benhabib, talk at HCP2011)*

## + Z boson

- Around 40 Z candidates in both  
ATLAS [Phys. Lett. B 697 \(2011\) 294-312](#)  
CMS [PRL 106, 212301 \(2011\)](#)
  - Almost background free (one like sign count only)
- Z production scales with the number of NN collisions

## ■ Comparaison to different theoretical predictions

- Using POWHEG cross-section:

$$- d\sigma_{pp} / dy = 59.6 \text{ pb in } |y| < 2$$

$$\text{The resulting } R_{AA} \text{ is: } dN_{AA} / (T_{AB} d\sigma_{pp}) \\ = 1.00 \pm 0.16 \pm 0.14$$

Heavy ion run @2.76 TeV

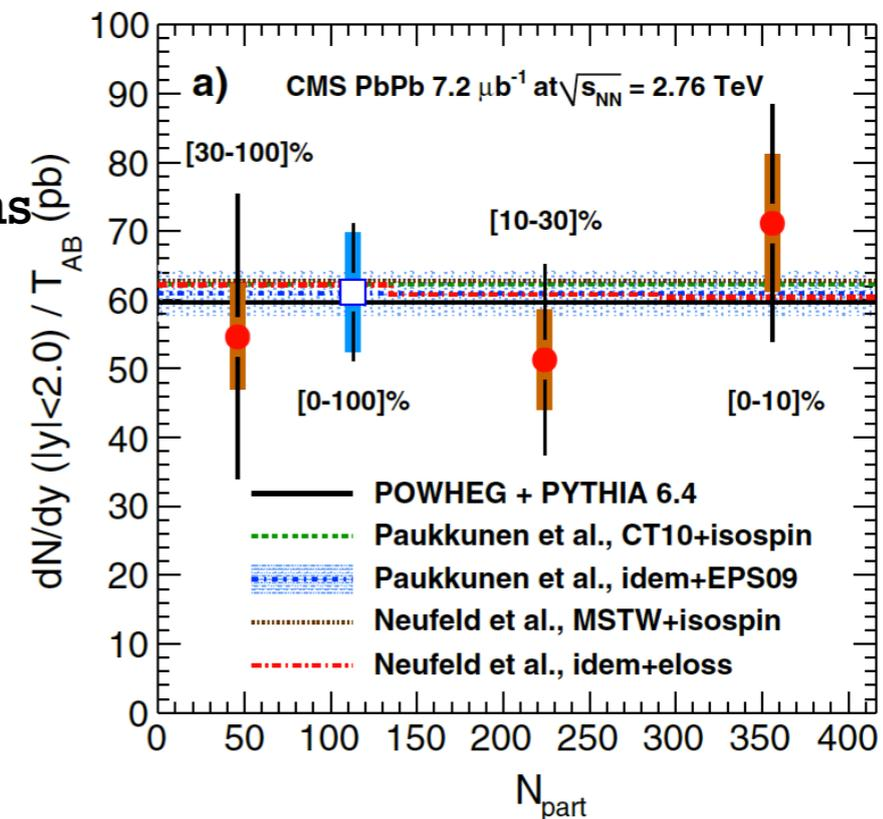
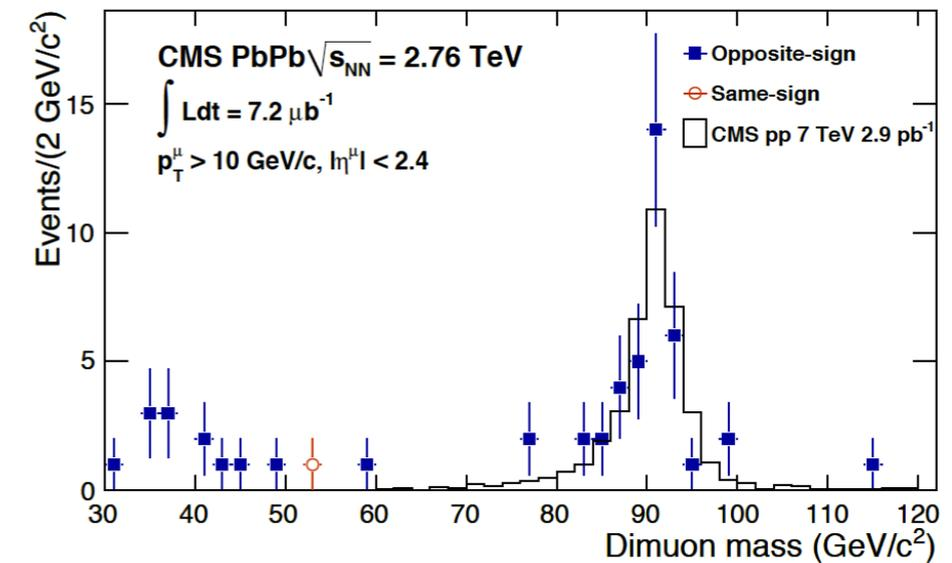

# Hard probes : testing pQCD in Pb-Pb collisions

(from Lamia Benhabib, talk at HCP2011)

## + Z boson

- Around 40 Z candidates in both ATLAS [Phys. Lett. B 697 \(2011\) 294-312](#) and CMS [PRL 106, 212301 \(2011\)](#)
  - Almost background free (one like sign count only)

■ Z production scales with the number of NN collisions

- Comparison to different theoretical predictions

- Using POWHEG cross-section:

$$- d\sigma_{pp} / dy = 59.6 \text{ pb in } |y| < 2$$

$$\text{The resulting } R_{AA} \text{ is: } dN_{AA} / (T_{AB} d\sigma_{pp}) = 1.00 \pm 0.16 \pm 0.14$$

Heavy ion run @2.76 TeV

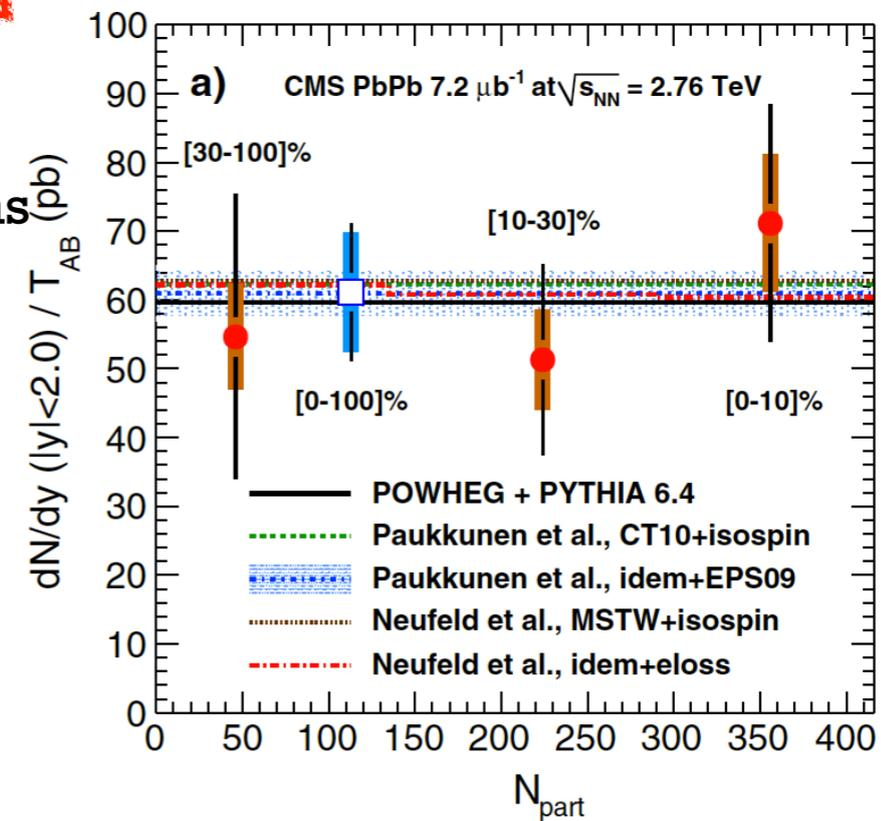
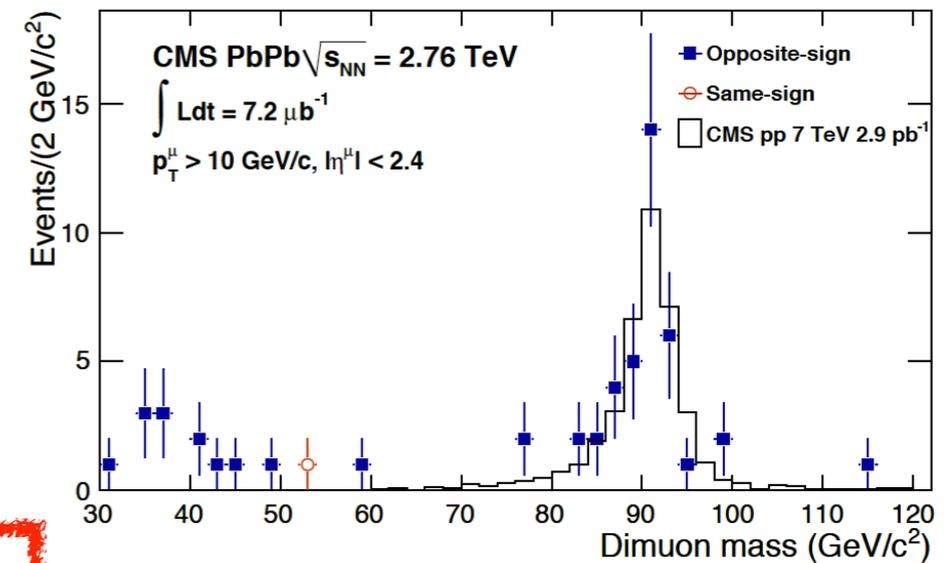

# Hard probes : testing pQCD in Pb-Pb collisions

(from Lamia Benhabib, talk at HCP2011)

## + W boson

- W signal: built a template from  $W \rightarrow \mu\nu$  decays
  - Use MC @  $\sqrt{s} = 2.76\text{TeV}$
- Use a function to describe background and find the best estimate of number of W with fitting signal + background to data

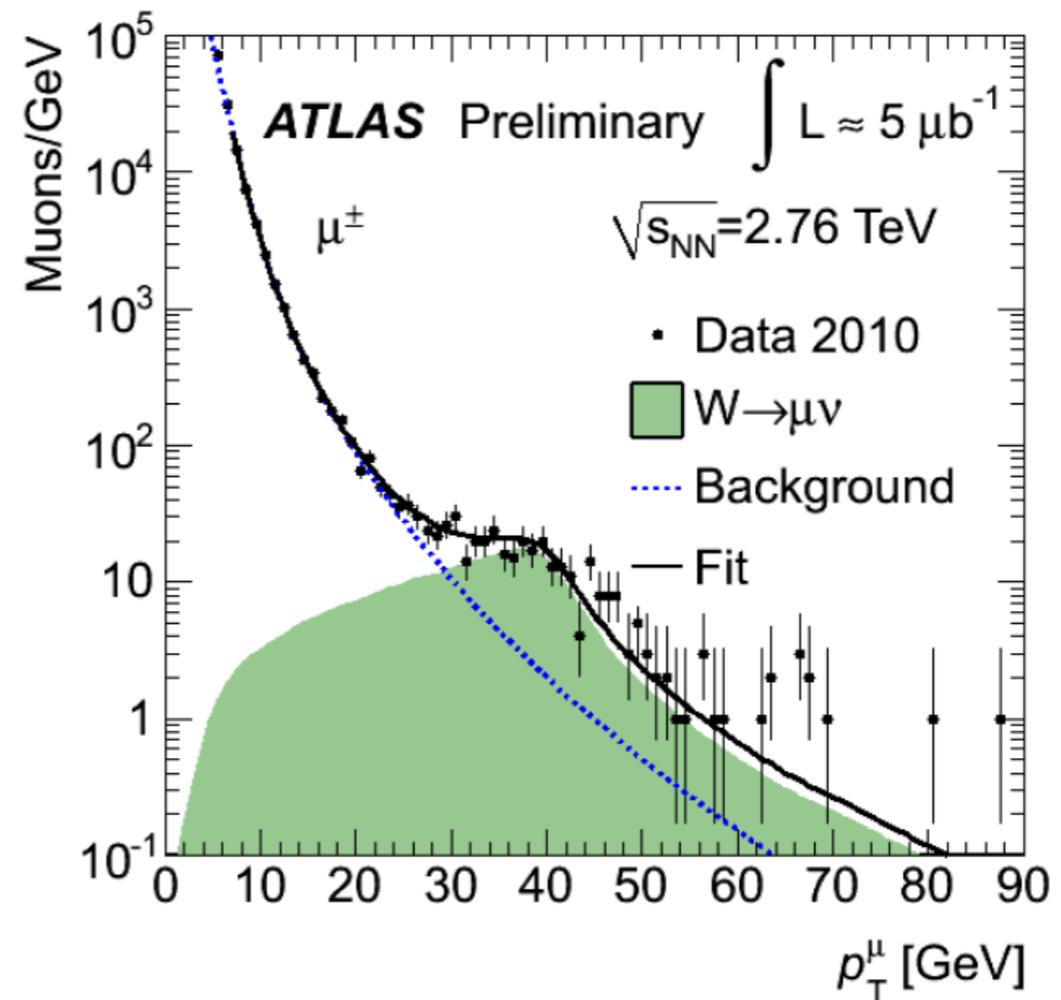
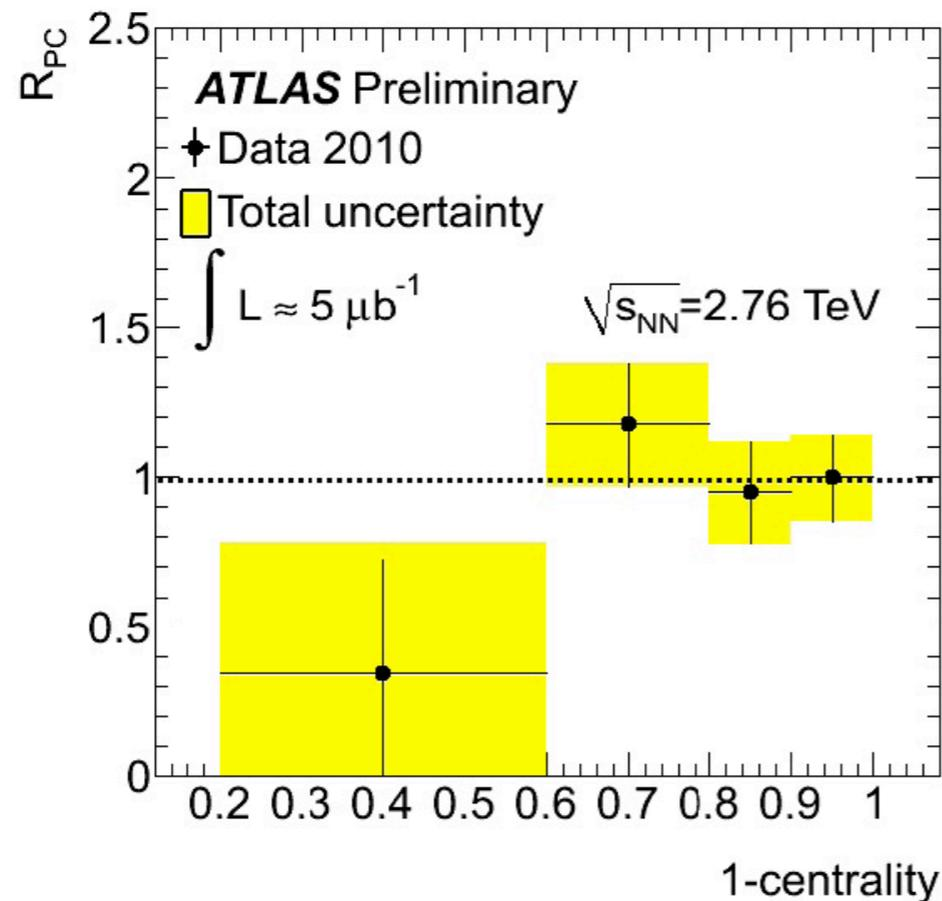

The results are consistent with no suppression

$R_{W/Z} = 10.5 \pm 2.3$  : in agreement with standard model prediction

# Hard probes : testing pQCD in Pb-Pb collisions

(from Lamia Benhabib, talk at HCP2011)

## + W boson

- W signal: built a template from  $W \rightarrow \mu\nu$  decays
  - Use MC @  $\sqrt{s} = 2.76\text{TeV}$
- Use a function to describe background and find the best estimate of number of W with fitting signal + background to data

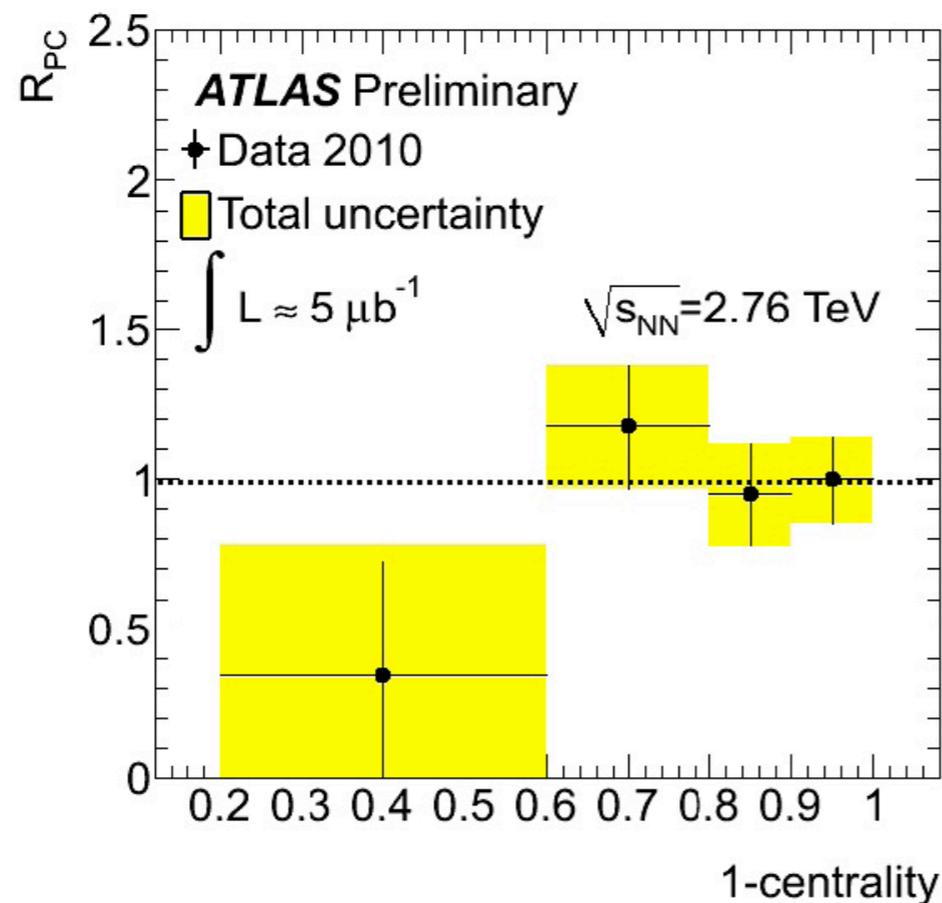
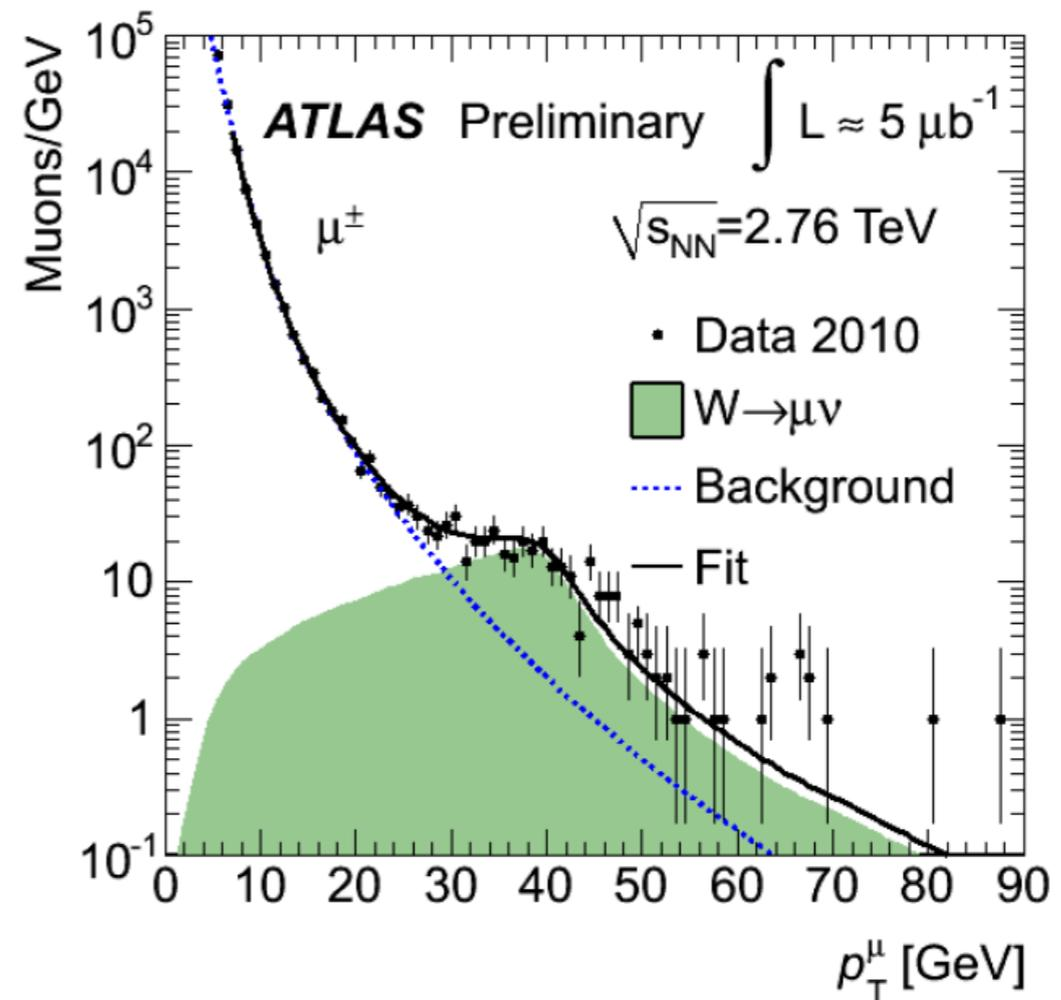

The results are consistent with no suppression

$R_{W/Z} = 10.5 \pm 2.3$  : in agreement with standard model prediction

# Strongly-interacting hard probes: jet quenching in a quark-gluon plasma

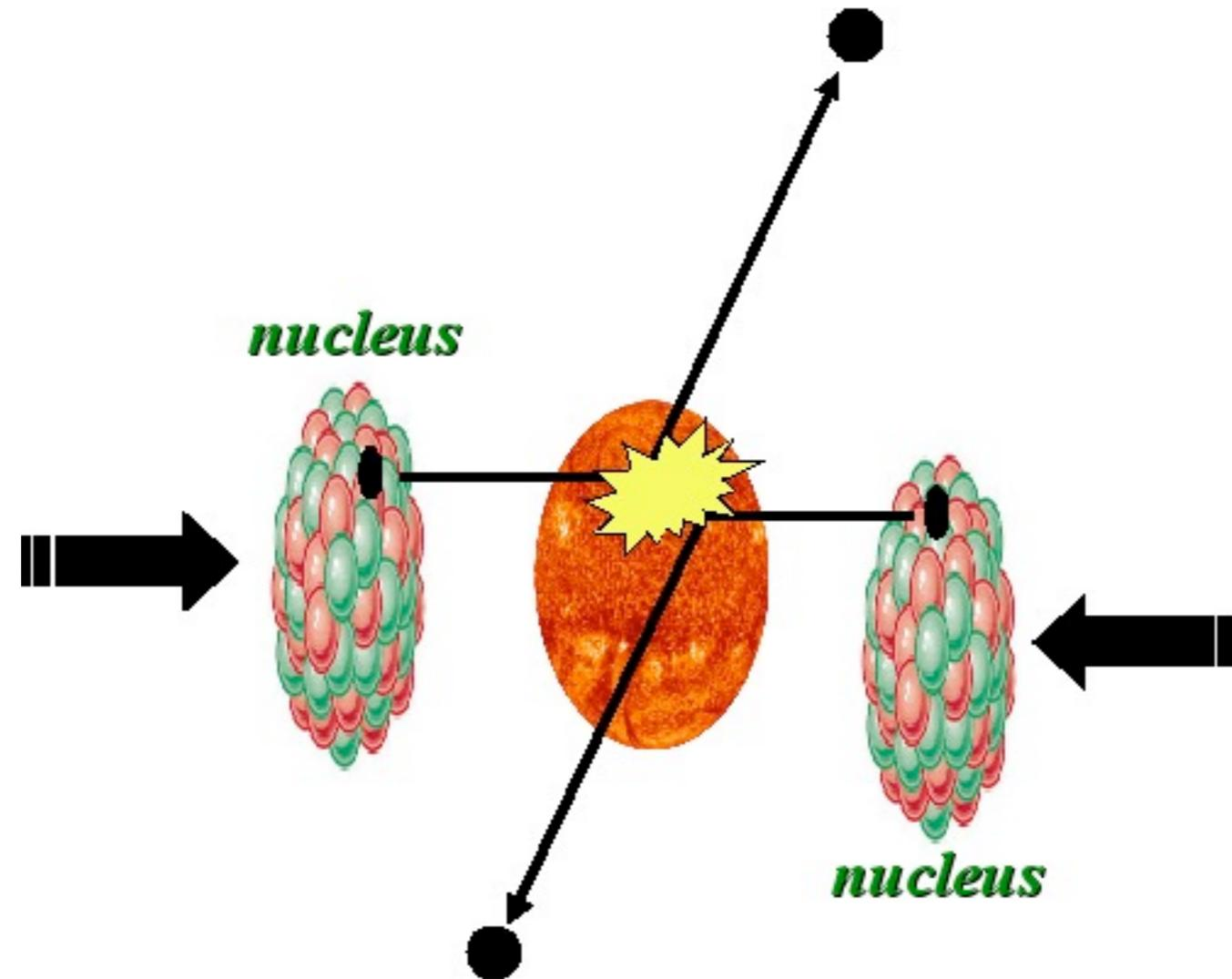

- ▶ Suppression of high  $p_t$  hadrons (leading particles)
- ▶ One jet loses more energy : dijet asymmetry

# Early observations of jet quenching: suppression of high-pt particles

HT: X-N Wang et al, arXiv:1102.5614 (PRC)  
HT: Majumder, Shen, arXiv:1103.0809  
TR: T. Renk et al, arXiv:1103.5308 (PRC)  
WHDG: Horowitz and Gyulassy, arXiv:1104.4958

$R_{AA}$   
= ratio Pb-Pb/pp,  
divided by number of  
binary collisions  
= observed/perturbative

*(from M. van Leeuwen,  
talk at HCP2011)*

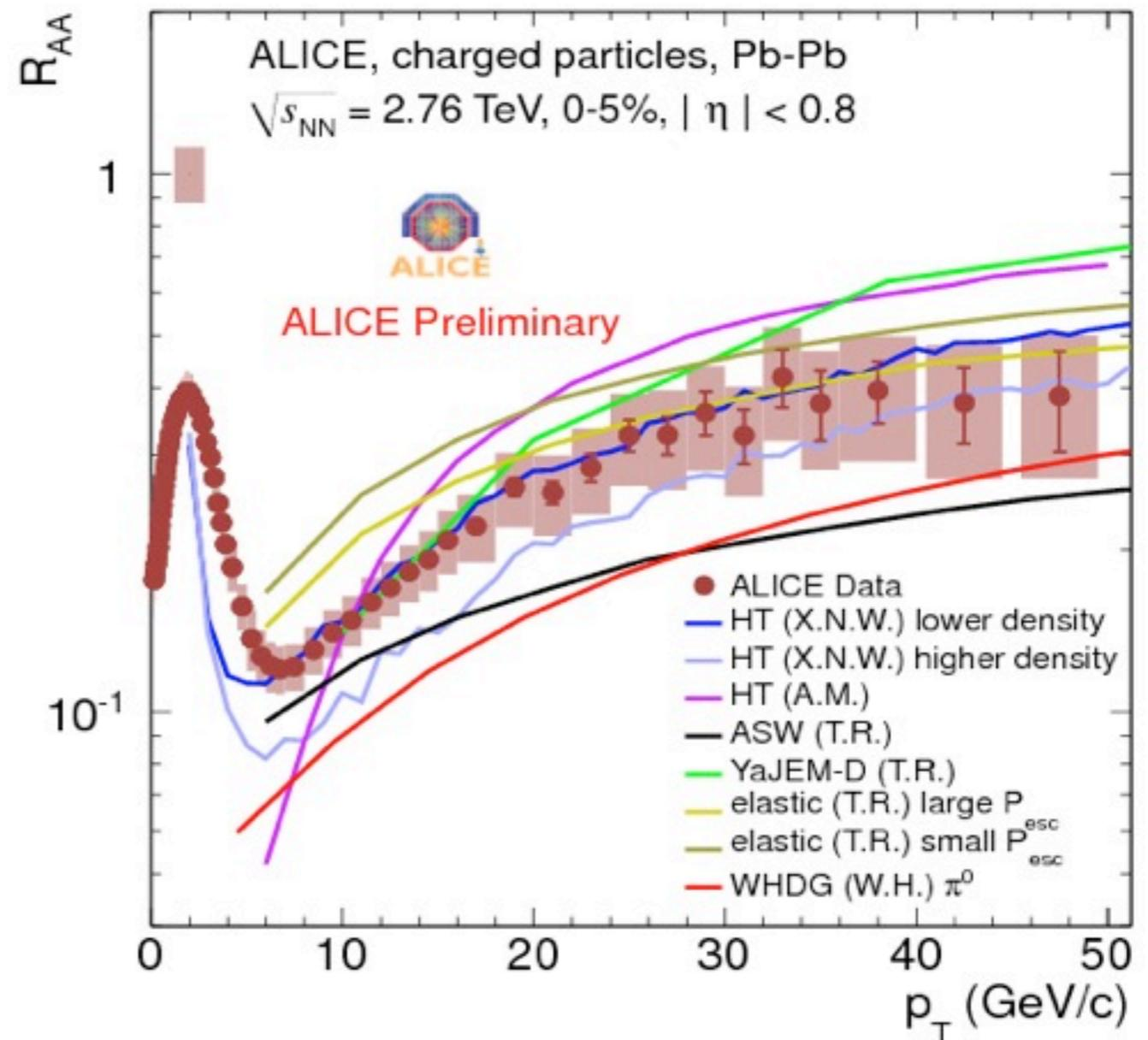

# Studying quenching with fully reconstructed jets

(from Lamia Benhabib, talk at HCP2011)

## + Dijet imbalance

- Dijet selection
  - Leading jet  $p_T > 100 \text{ GeV}/c$
  - Subleading jet  $p_T > 25 \text{ GeV}/c$
- Quantify dijet imbalance by **asymmetry ratio**

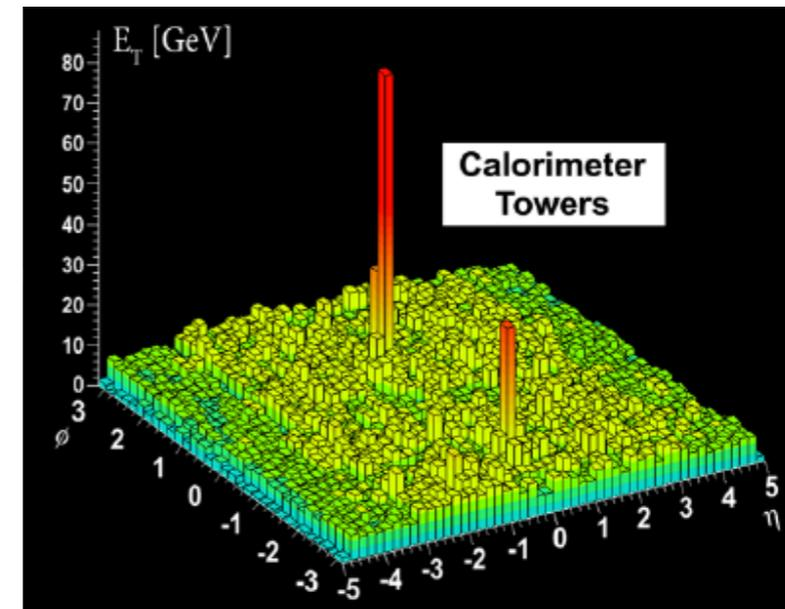

$$A_j = \frac{E_{T1} - E_{T2}}{E_{T1} + E_{T2}}$$

[ATLAS, Phys. Rev. Lett 105 \(2010\) 252303](#)

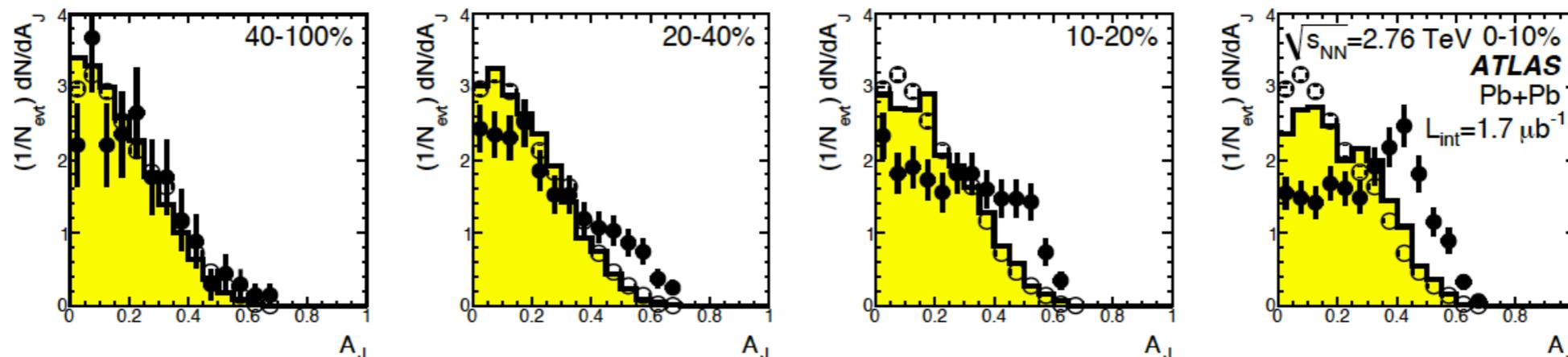

- Larger imbalance in central collisions, but not in peripheral collisions, with respect to pp reference
- Parton energy loss is observed as pronounced energy imbalance in reconstructed dijets

# Conclusions

- Ultrarelativistic heavy-ion collisions produce a lump of fluid, with an extremely low viscosity/entropy, characteristic of a strongly-coupled plasma.
- Quantum fluctuations+flow+viscous damping generate the anisotropies observed in the little bang. This is very similar to the mechanism driving CMB anisotropies in big bang cosmology.
- Soft physics in heavy-ion collisions is largely understood from first principles. Room for progress in understanding of “initial state” and fluctuations.

# Backup slides

# Models for the multiplicity

The increase of particle multiplicity from RHIC to LHC was accurately predicted using evolution equations from perturbative QCD (running coupling BK)

*More generally, properties of the initial state can be studied within a perturbative framework, generally known as CGC (color glass condensate)*

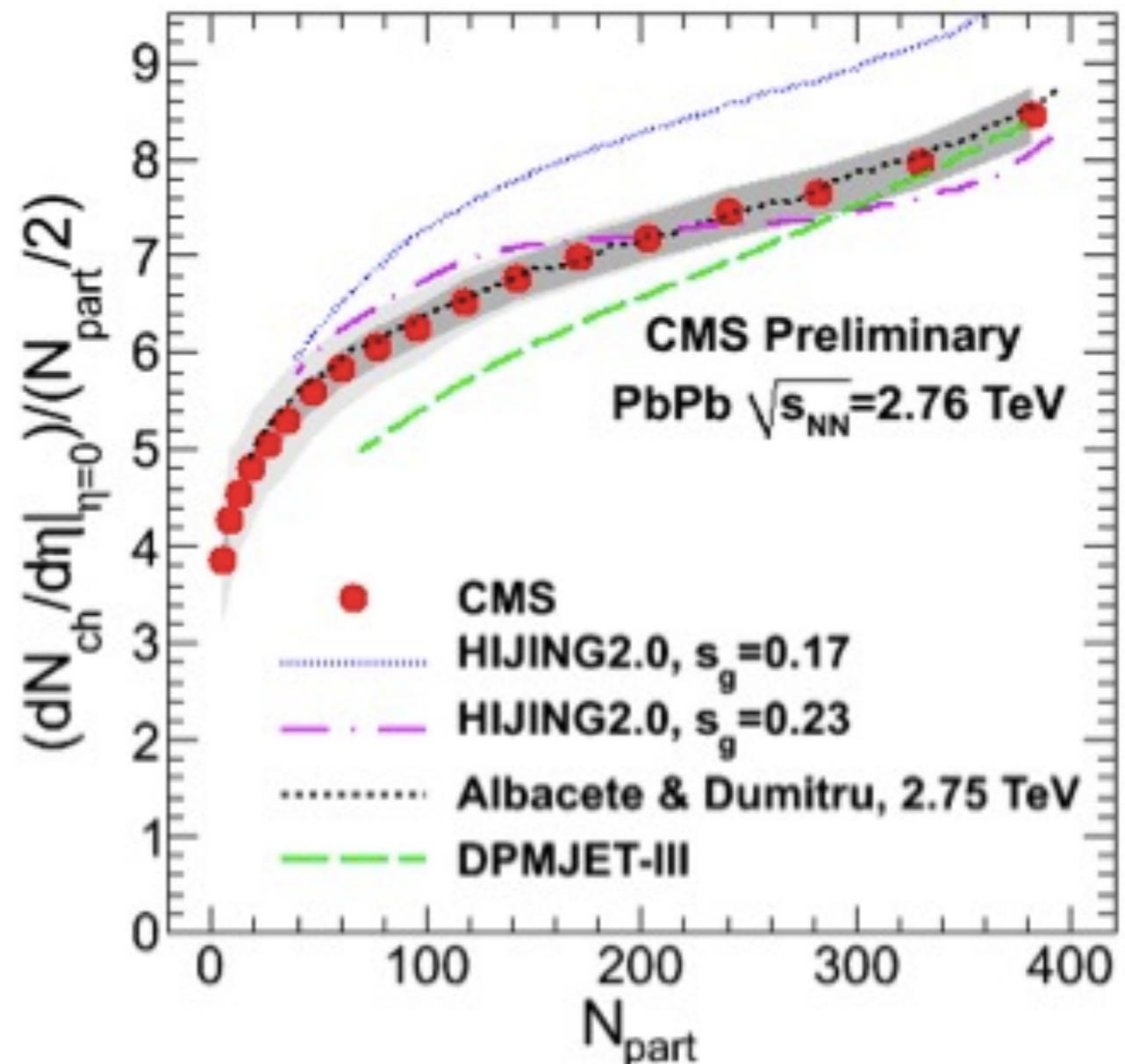

*(B. Wyslouch, talk at Quark Matter 2011)*

# Correlations in central Pb-Pb

central collisions are  $\Phi$  symmetric, except for fluctuations!

$$(1+[0]*\text{TMath}::\text{Cos}(2*y))*(1+[1]*x)$$

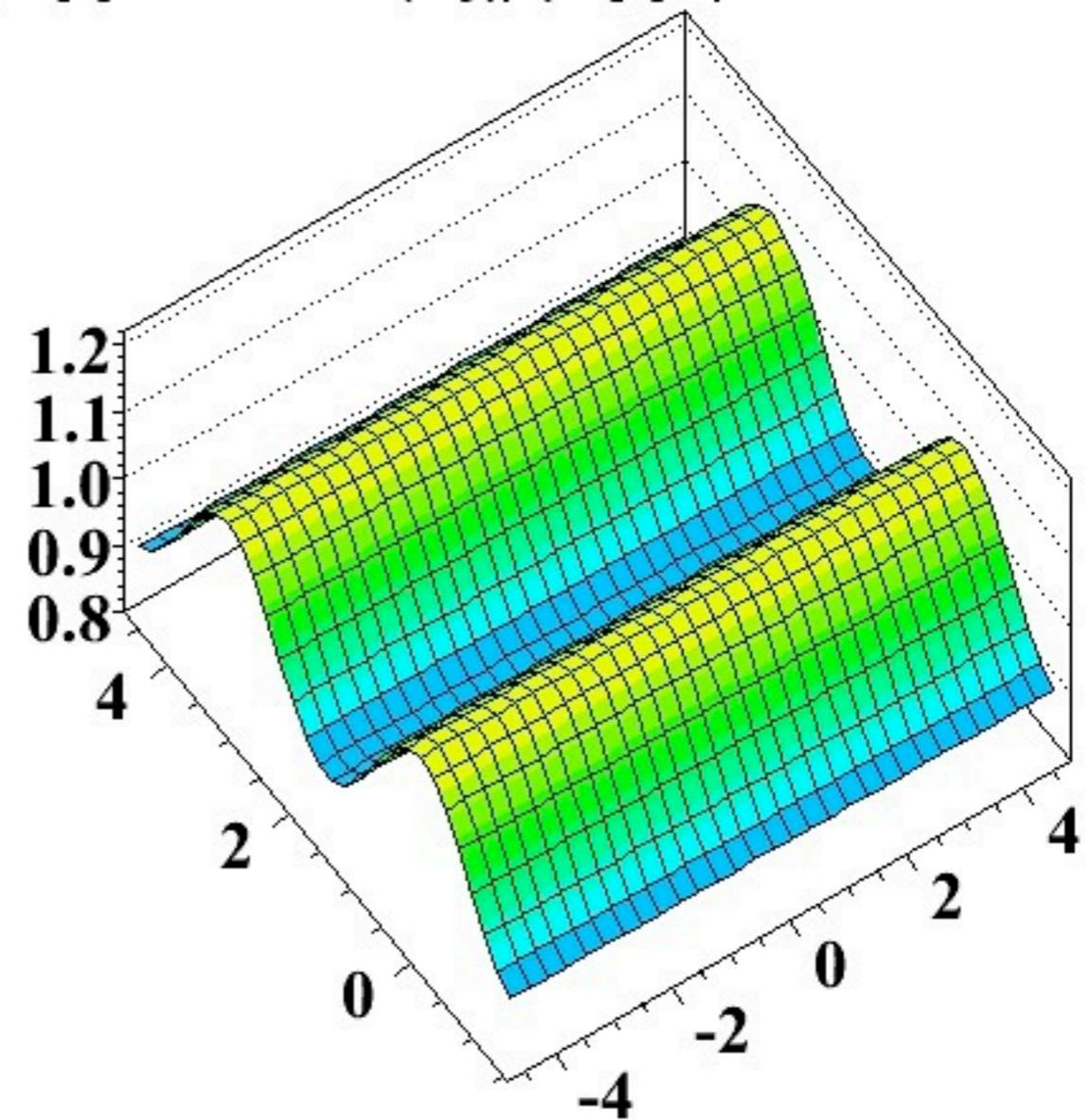
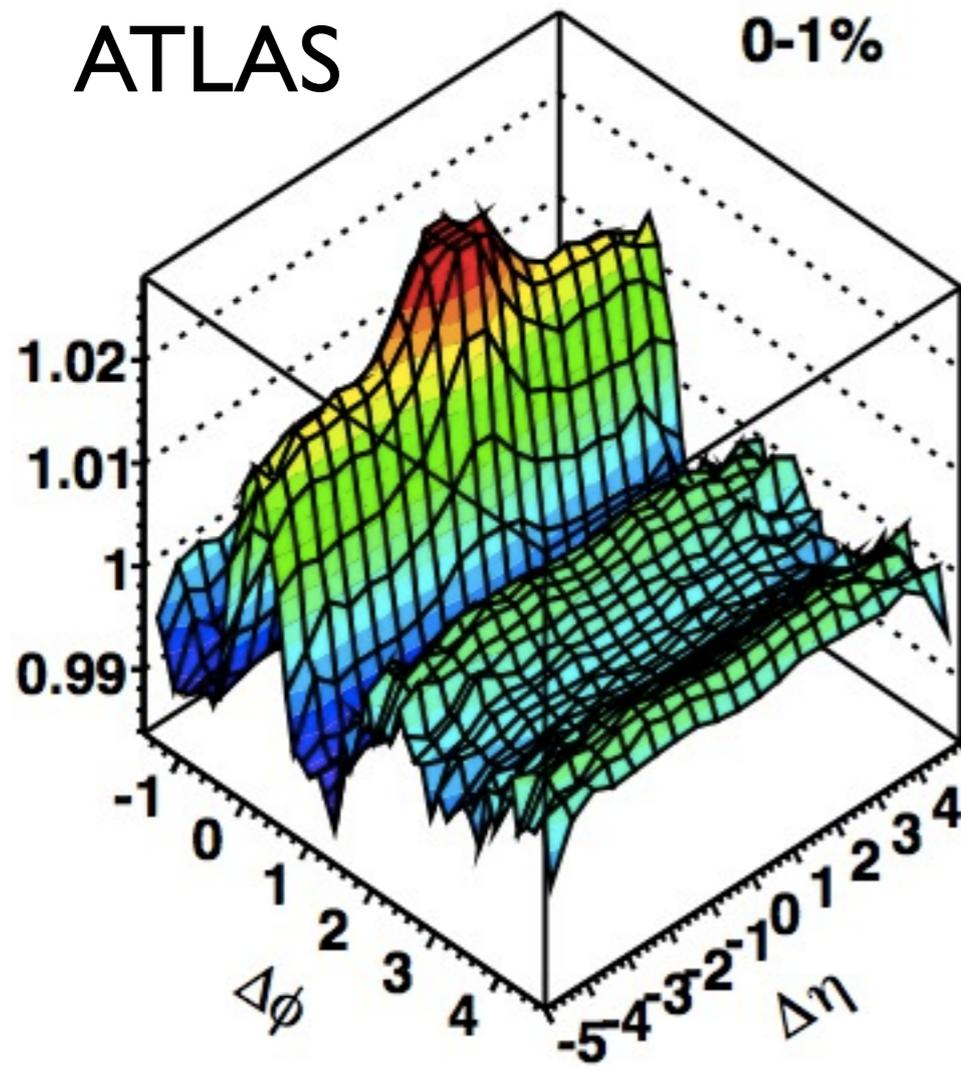

*Jia @ATLAS, talk at QM2011*

*Wei Li@CMS, talk at QM2011*

# Correlations in central Pb-Pb

central collisions are  $\Phi$  symmetric, except for fluctuations!

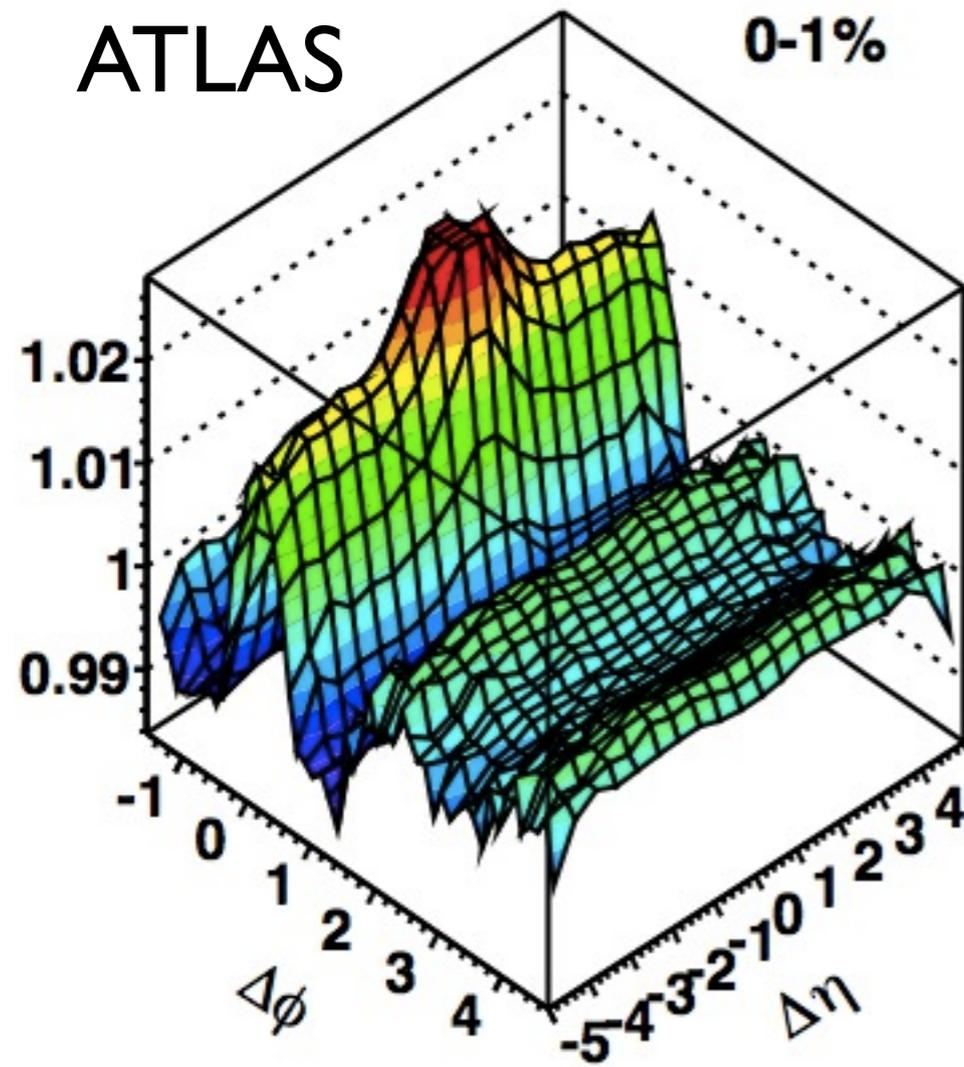

*Jia @ATLAS, talk at QM2011*

$$(1 + [0] \cdot \cos(3 \cdot y)) \cdot (1 + [1] \cdot x)$$

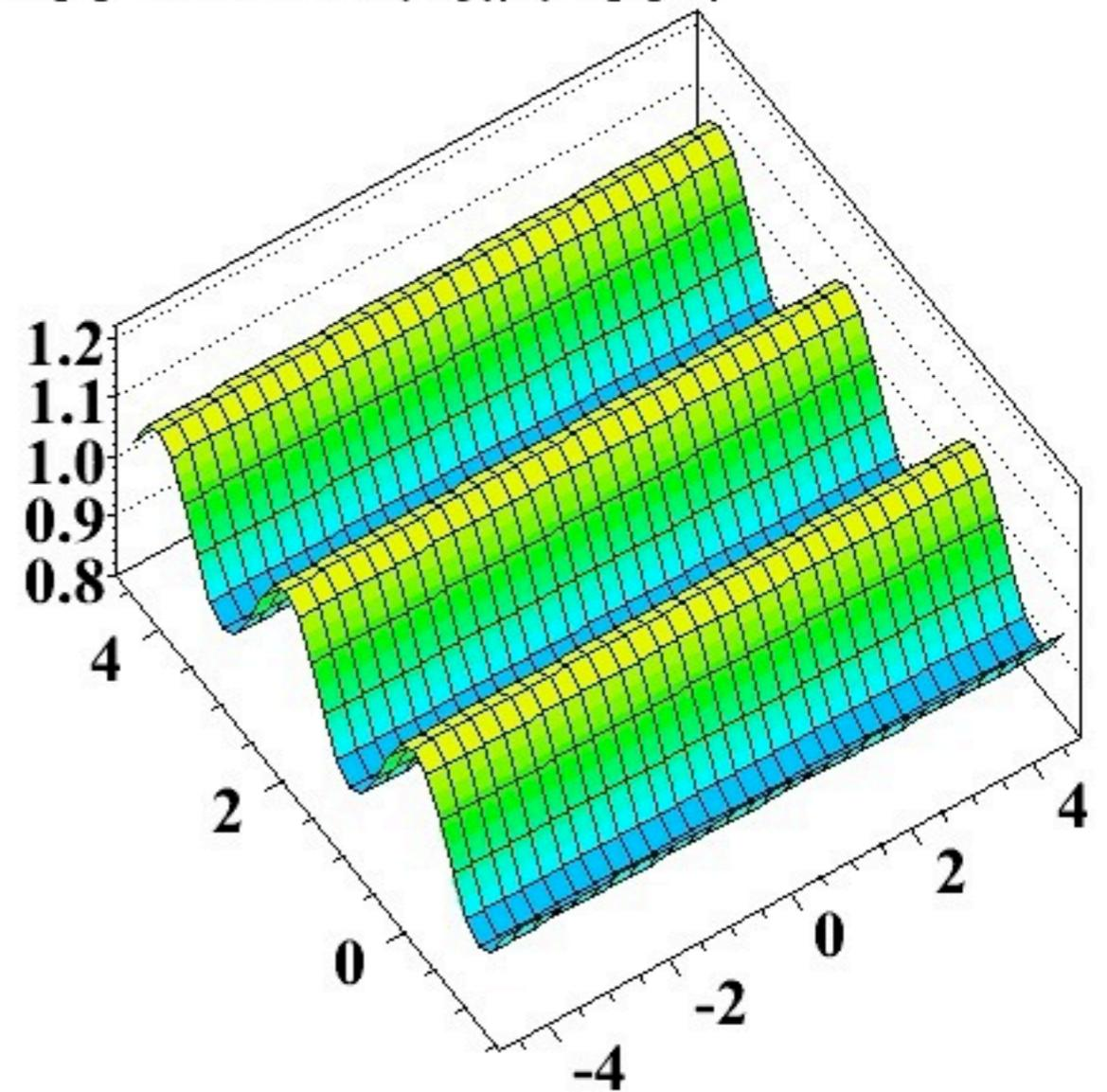

*Wei Li@CMS, talk at QM2011*

# Correlations in central Pb-Pb

central collisions are  $\Phi$  symmetric, except for fluctuations!

$$(1+[0]*\text{TMath::Cos}(3*y)+[2]*\text{TMath::Cos}(2*y))*(1+[1]*x)$$

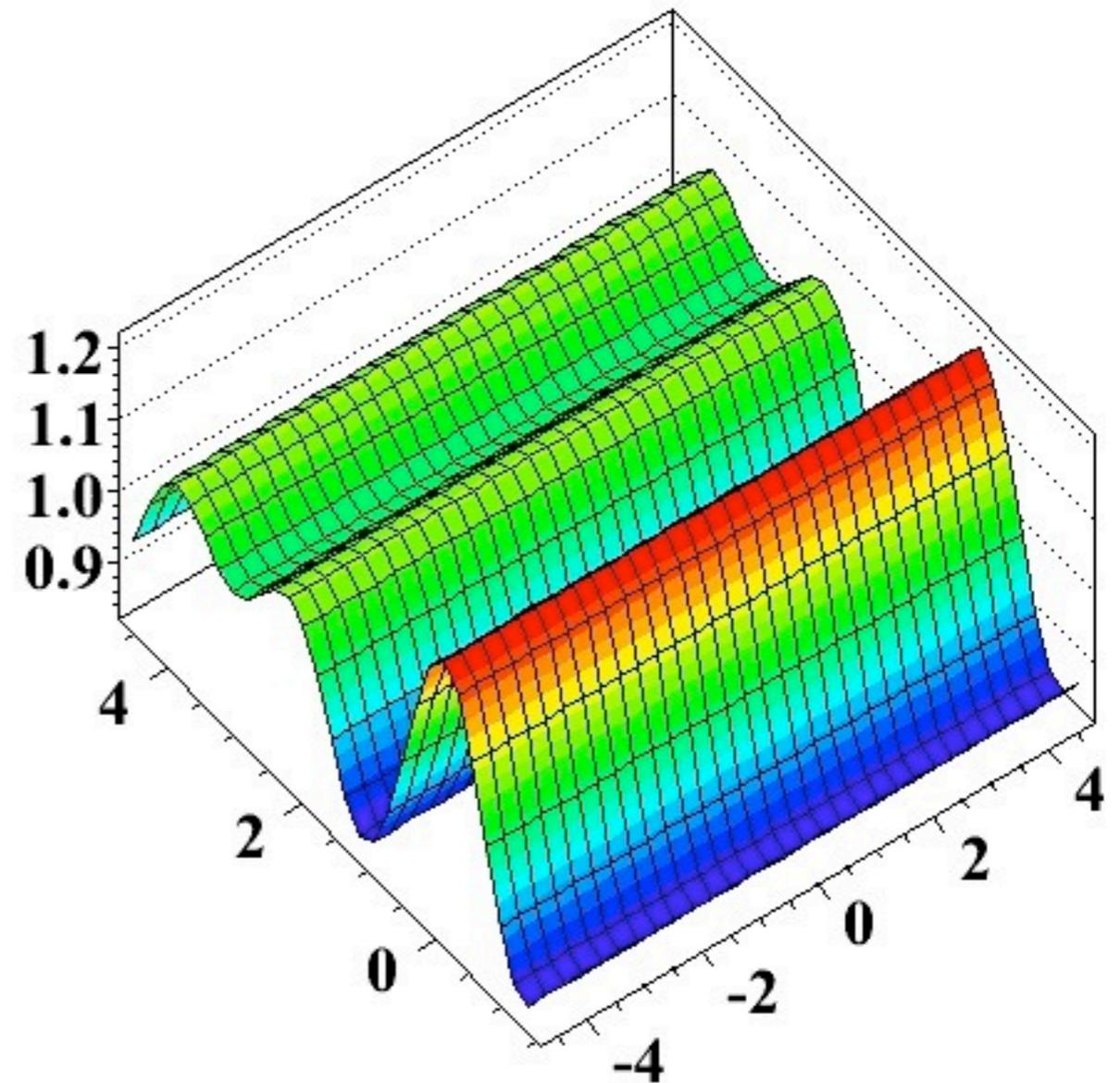
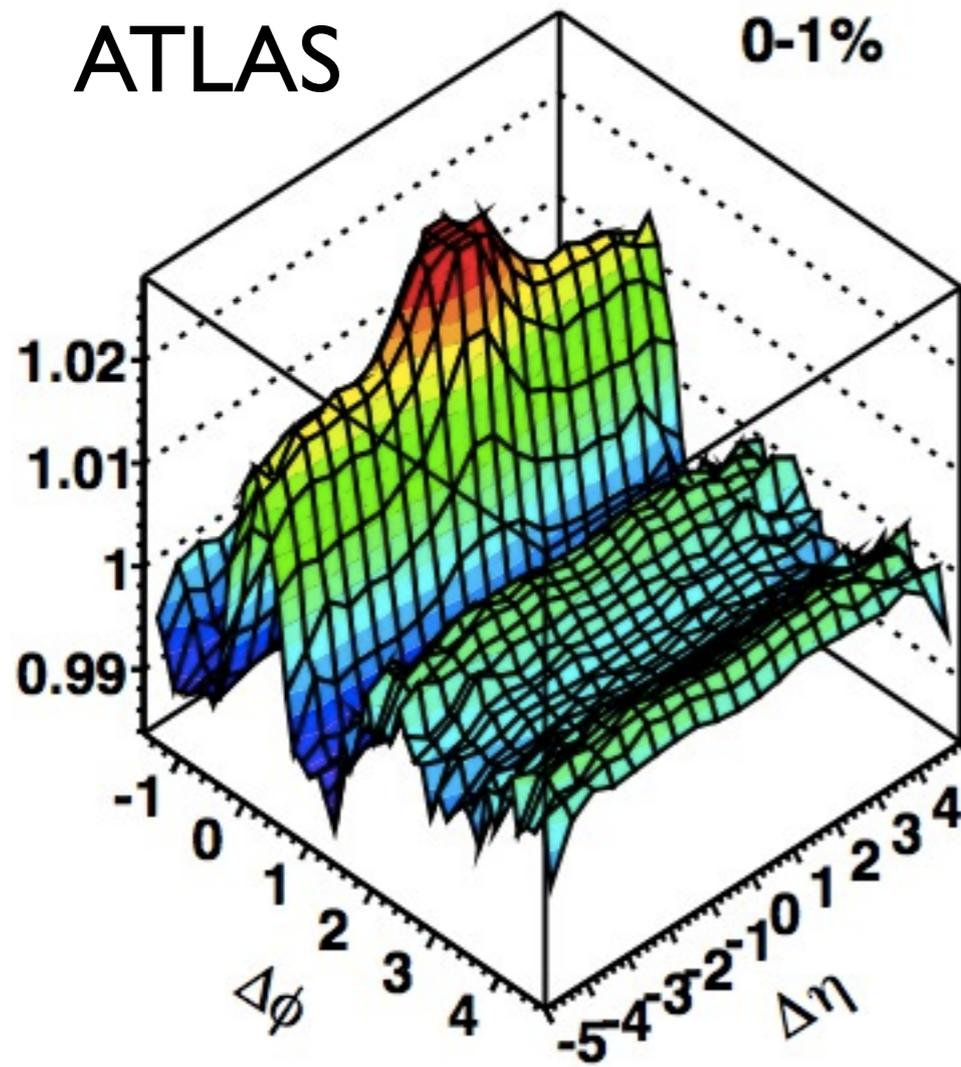

*Jia @ATLAS, talk at QM2011*

*Wei Li@CMS, talk at QM2011*



# Identified particle spectra (Michele Floris, talk at Quark Matter 2011)

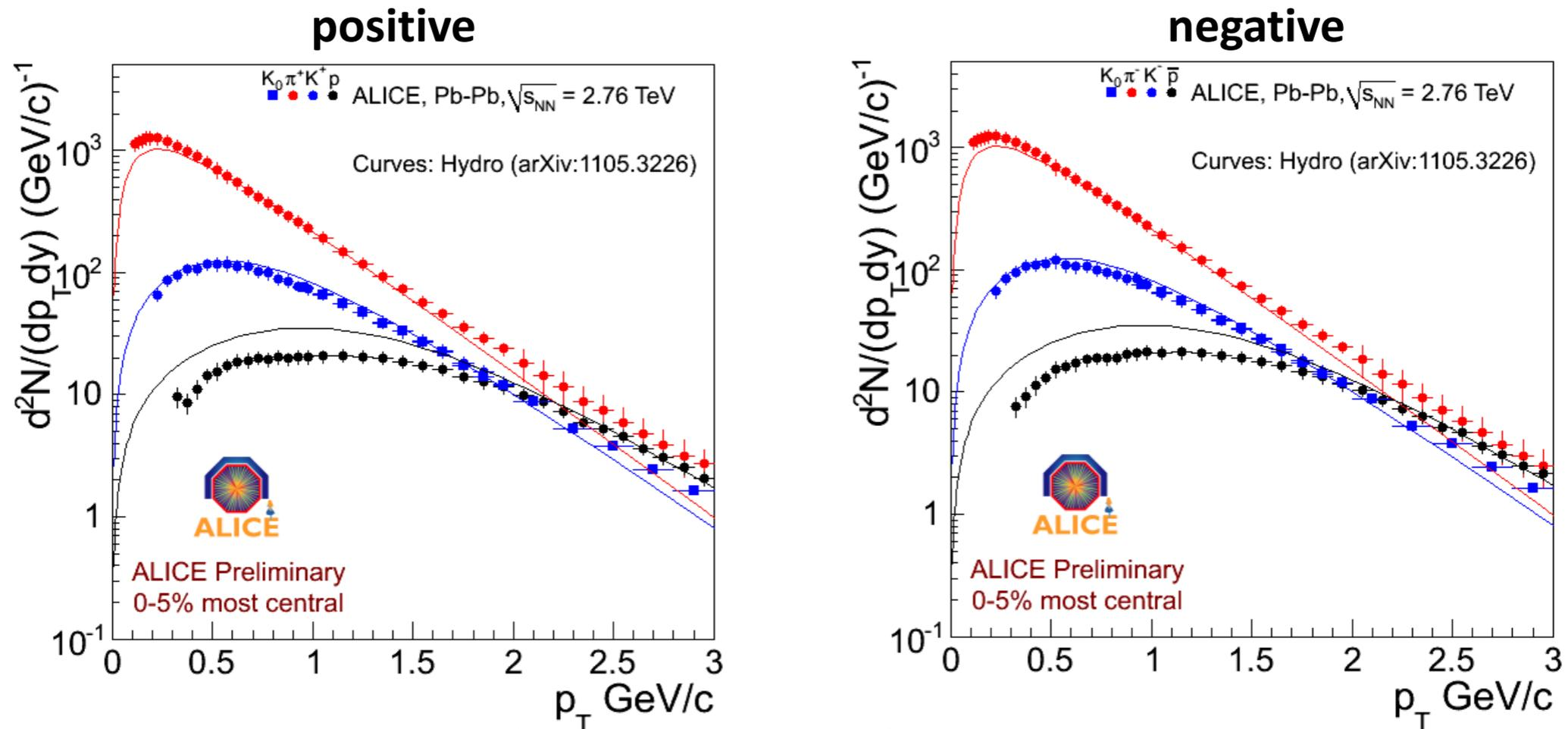

At RHIC: STAR proton data generally not feed-down corrected.

Large feed down correction

→ Consistent picture with feed-down corrected spectra

At LHC: ALICE spectra are **feed-down corrected**

- Harder spectra, flatter p at low p<sub>T</sub>
- **Strong push** on the p due to radial flow?

*STAR, PRL97, 152301 (2006)*

*STAR, PRC 79, 034909 (2009)*

*PHENIX, PRC69, 03409 (2004)*

# Hydro prediction versus 1<sup>st</sup> LHC data

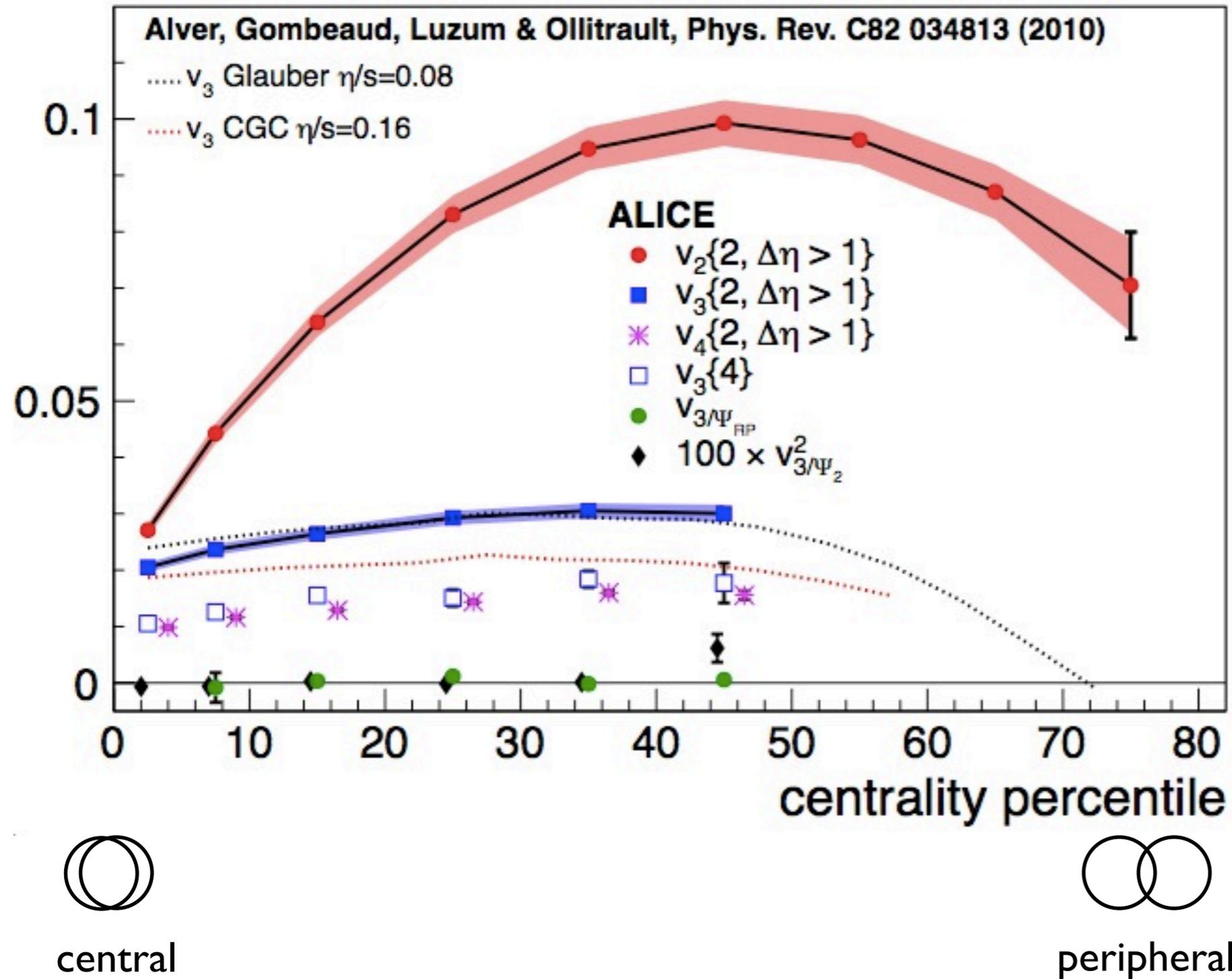

*Raimond Snellings,  
 plenary talk  
 at QM2011*

*ALICE,  
 arXiv:1105.3865  
 [nucl-ex]*

# $v_2(p_T)$ and $v_3(p_T)$ : sensitivity to $\eta/s$

Glauber initial conditions

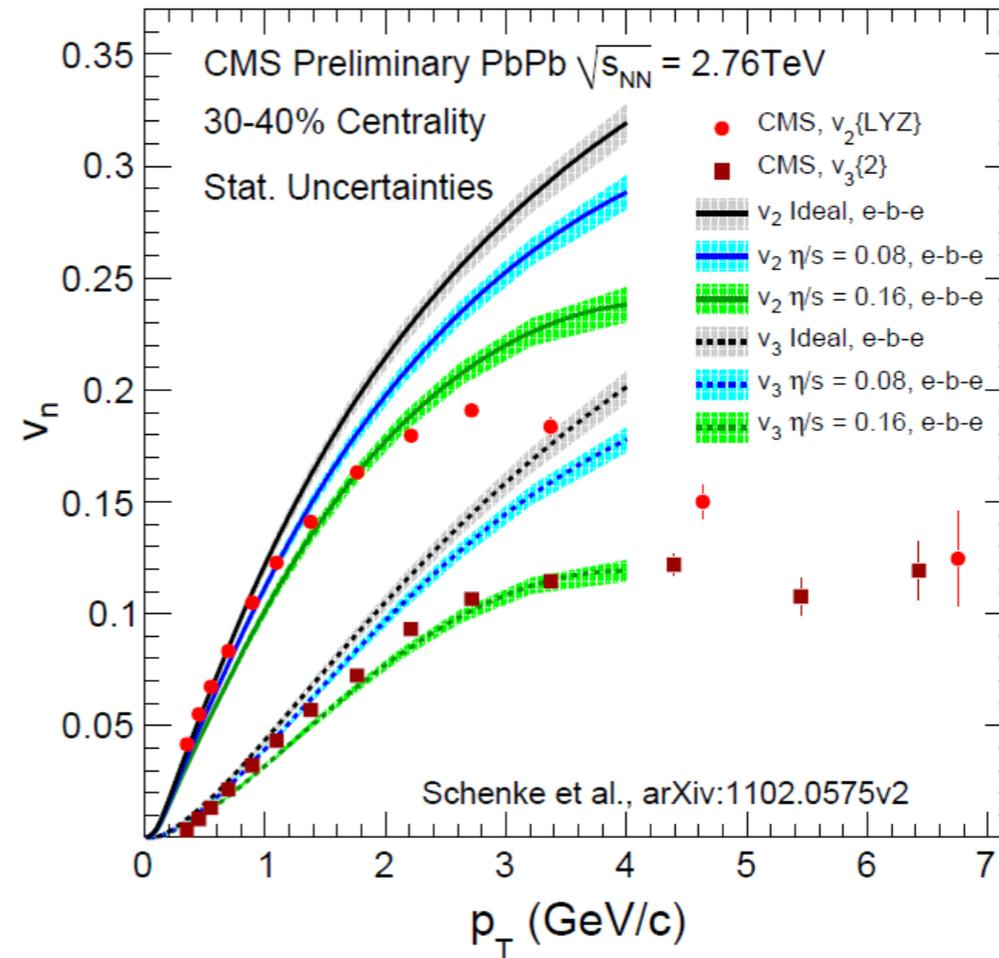
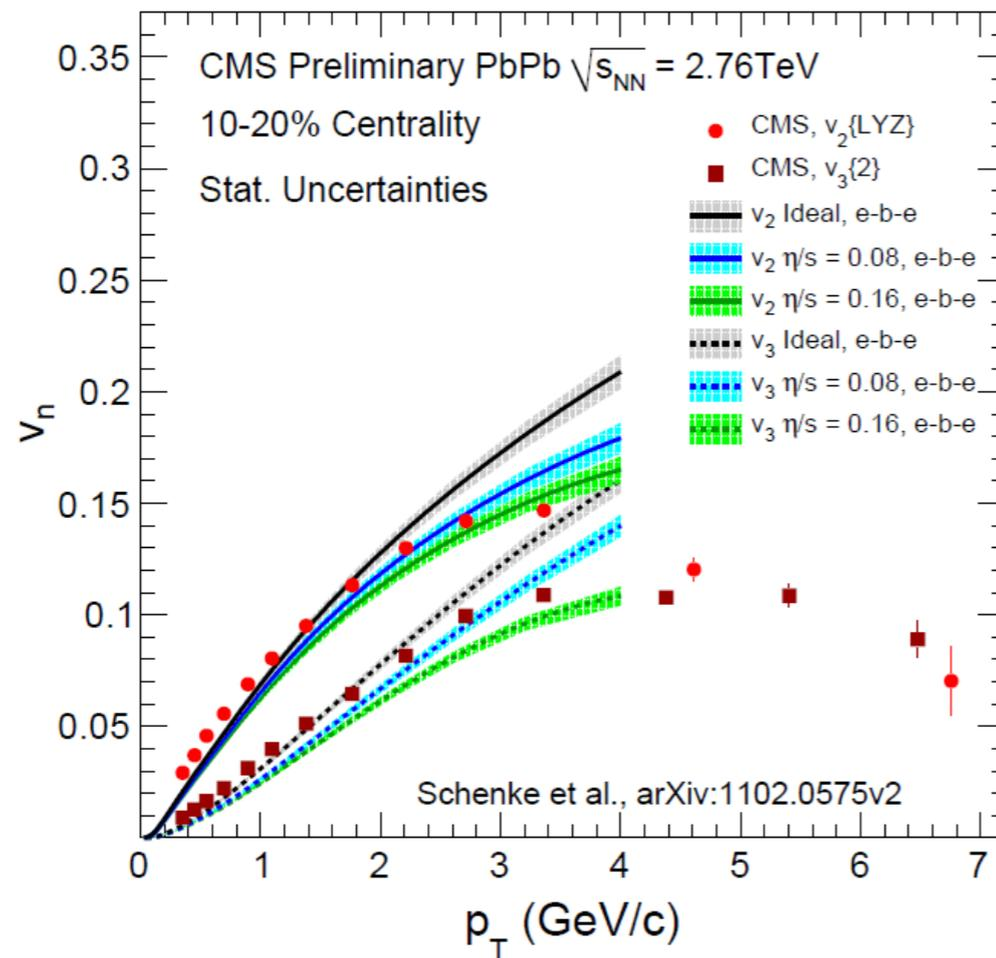

- $v_2$  and  $v_3$  together have better sensitivity
- The centrality dependence adds further constraints



# Other Harmonics

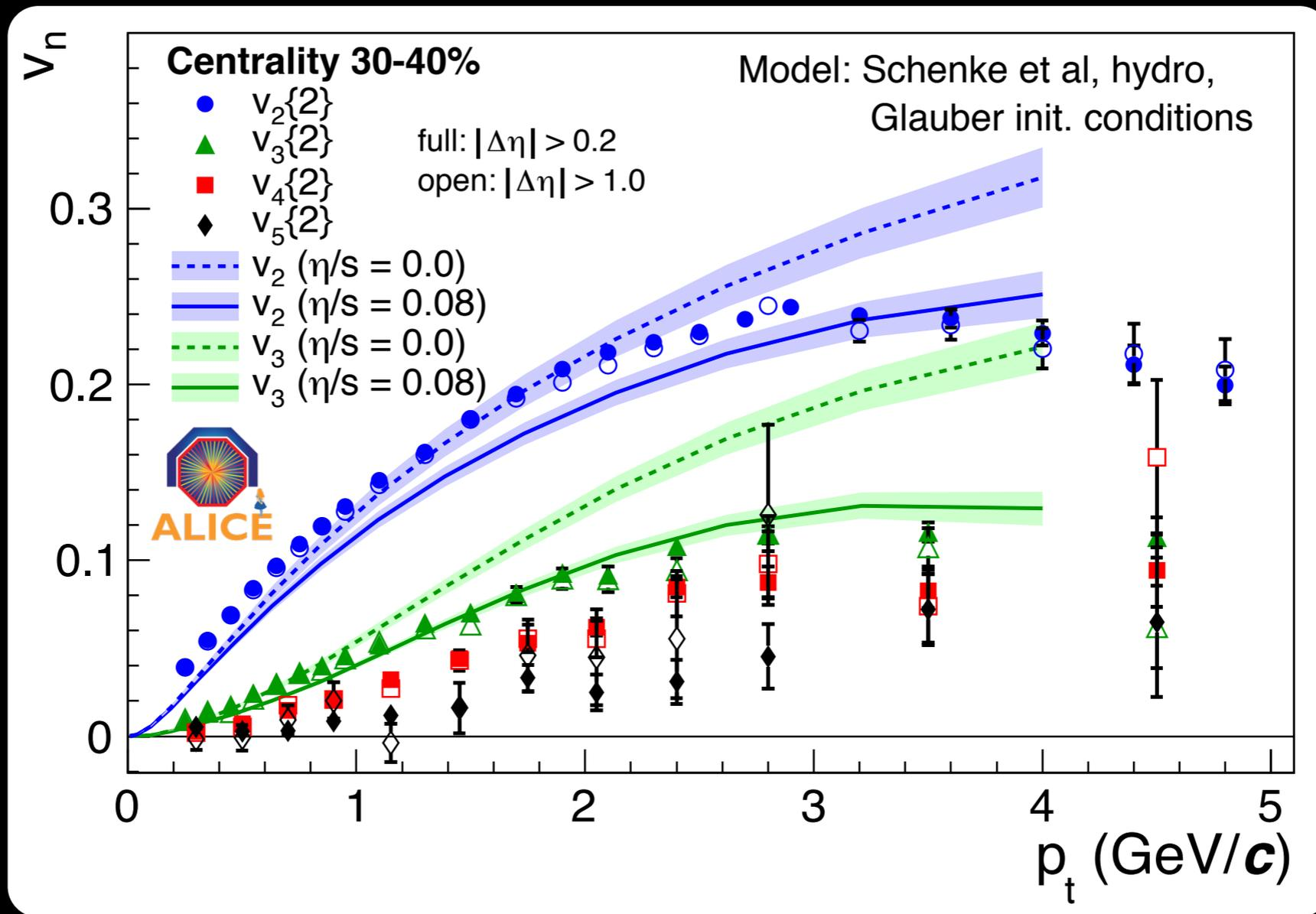

ALICE Collaboration, arXiv:1105.3865

see presentation A. Bilandzic

The overall dependence of  $v_2$  and  $v_3$  is described  
However there is no simultaneous description with a single  $\eta/s$  of  $v_2$  and  $v_3$  for Glauber initial conditions

# $v_1$ from fluctuations not yet measured!

Extracted from 2-particle correlation data at RHIC

*Luzum JY0, Phys. Rev. Lett. 106:102301 (2011)*  
*STAR arXiv:1010.0690*

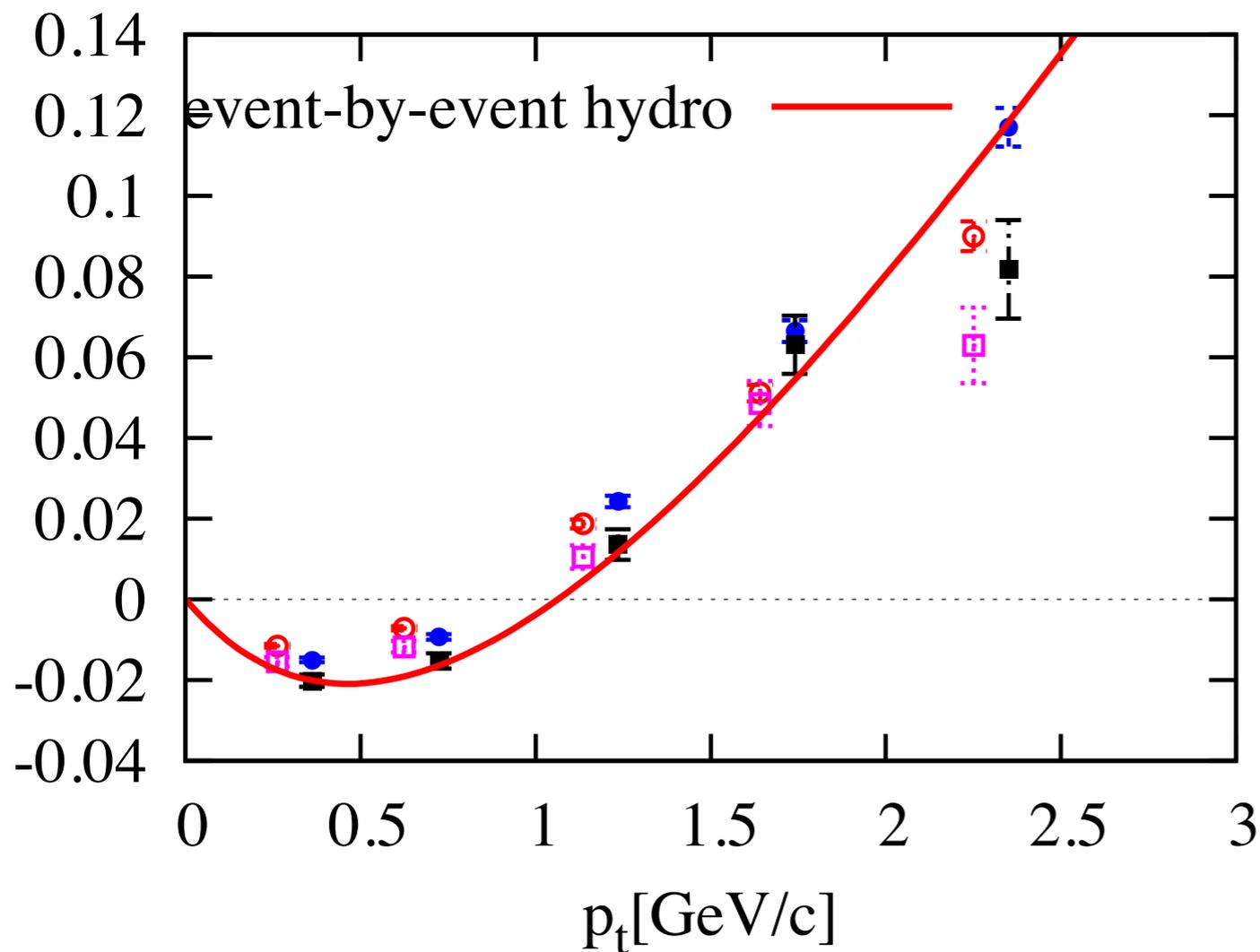

Well reproduced by ideal hydrodynamics

*Gardim Grassi Hama Luzum JY0*  
*arXiv:1103.4605*

# Flow vs. non-flow correlations

## Collective effects

Flow-related effects imply correlation through a plane of symmetry  $\psi_n$ .

Flow-dominated correlations should factorize:

$$\begin{aligned} \langle \cos n\Delta\varphi \rangle &= \langle \cos n(\varphi_{\text{trig}} - \varphi_{\text{assoc}}) \rangle \\ &= \langle \cos n(\varphi_{\text{trig}} - \psi_n) \rangle \langle \cos n(\varphi_{\text{assoc}} - \psi_n) \rangle \\ &= v_n(p_{T\text{trig}}) v_n(p_{T\text{assoc}}) \end{aligned}$$

Pair coefficients are just products of familiar single-particle  $v_n$ s.

## Jet-related effects

A few energetic particles are highly correlated by fragmentation, but not directly through  $\psi_n$ .

**Caveat:** there can be indirect correlations, i.e. length-dependent quenching.

Would be largest w.r.t.  $\psi_2$  since it reflects the collision geometry.

The collectivity relation

$$\langle \cos n\Delta\varphi \rangle \stackrel{?}{=} v_n(p_{T\text{trig}}) v_n(p_{T\text{assoc}})$$

is a quantitative hypothesis that can be tested!

# Global fit of 2-particle Fourier moments

Find best  $v_n(p_T)$

Fit  $\langle \cos n\Delta\phi \rangle$  for all  $p_T$  bins simultaneously

Fit function:  $V_{n\Delta} = v_n^t v_n^a$ .

Fit breaks at high  $p_T$ , where jets dominate.

Key idea

If fit matches data  
suggests flow-type correlations

If fit diverges  
collective description less appropriate.

Transition between cases follows clear trends.

